

SPECTRUM DISPLAY

3720A

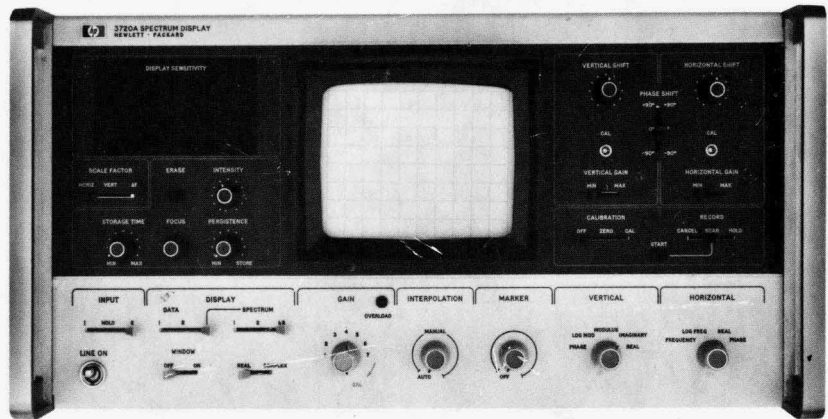

HEWLETT  PACKARD

HEWLETT  PACKARD

SERVICE MANUAL

MODEL 3720A SPECTRUM DISPLAY

SERIAL PREFIX

This manual applies to all instruments having serial prefix 1209U. Instruments with a serial prefix above 1209U *may* have a Manual Change Sheet, to which reference should be made.

WWW.HPARCHIVE.COM
For Free Distribution Only

Copyright HEWLETT-PACKARD LIMITED 1972
SOUTH QUEENSFERRY, WEST LOTHIAN, SCOTLAND

	3-8	LIST OF ABBREVIATIONS	3-2
	3-9	COLOUR ABBREVIATIONS	3-3
Table	3-1	Replaceable Parts	3-4
	3-2	Code List of Manufacturers	3-50
Figure	3-1	Location of cabinet components	3-49

SECTION IV SYSTEM TROUBLESHOOTING

Paragraph	4-1	INTRODUCTION	Page 4-1
	4-3	USING TROUBLESHOOTING SECTION	4-1
	4-8	TEST EQUIPMENT	4-2
	4-10	Logic Probe	4-2
	4-12	SYSTEM TROUBLESHOOTING CONTROLS SET-UP	4-3
	4-14	FLOW A – Control Faults	4-5
	4-16	FLOW B – Display Sensitivity Faults	4-6
	4-19	FLOW C – Data Transfer Faults	4-7
	4-21	FLOW D – Other Transferred Signals Faults	4-8
	4-23	FLOW D(a) – Timescale Transfer Faults	4-8
	4-25	FLOW D(b) – Gain Correction Factors Transfer Faults	4-9
	4-27	FLOW D(c) – Signal Recovery Transfer Faults	4-10
Table	4-1	Flow charts	4-1
	4-2	3721A/3720A System repair procedure	4-1
	4-3	Test equipment required for System Troubleshooting	4-2
	4-4	Range transfer check	4-6
	4-5	Range data logic check	4-6
	4-6	Timescale transfer check	4-9
	4-7	Gain correction factors check	4-10
	4-8	Signal recovery transfer check	4-10
Figure	4-1	750KHz	4-4
	4-2	Transfer Data duration	4-4
	4-3	Data Ready	4-4
	4-4	Transfer Data repetition rate	4-4
	4-5	Multiplexed range outputs	4-6

SECTION V SCHEMATICS, COMPONENT LOCATIONS, DIAGRAMS

Paragraph	5-1	INTRODUCTION	Page 5-1
	5-3	DRAWING SYMBOLS	5-1
	5-5	ASSEMBLY PACKAGES	5-1
	5-7	Locating Assembly Packages	5-1
	5-9	THEORY OF OPERATION	5-1
	5-10	Functional Diagram	5-1
Figure	5-1	Guide to schematics	5-2
	5-2	Logic package outlines	5-3

5-3	Functional diagram	5-4
5-4	Guide to logic symbols	5-4
5-5	Location of components (front and rear panels)	5-5
5-6	Location of assemblies and chassis mounted components (top view)	5-6
5-7	Location of assemblies and chassis mounted components (underside view)	5-7
5-8	Wiring of rotary switches	5-61
5-9	Wiring of rear panel connectors	5-63

A1 Not Assigned

A2 Mantissa Range Assembly Package

Figure	A2-1	Component location, A2	Page	5-10
	A2-2	Schematic A2 (part 1), Mantissa Range assembly		5-11
	A2-3	Schematic A2 (part 2), Mantissa Range assembly		5-13

A3 Decade Range Assembly Package

Figure	A3-1	Component location, A3	Page	5-14
	A3-2	Schematic A3, Decade Range assembly		5-15

A4 Store 1 Assembly Package

Table	A4-1	Component identification grid, A4	Page	5-17
Figure	A4-1	Component location, A4		5-16
	A4-2	Schematic A4 (part 1), Store 1 assembly		5-17
	A4-3	Schematic A4 (part 2), Store 1 assembly		5-19

A5 Store 2 Assembly Package

Figure	A5-1	Component location, A5	Page	5-20
	A5-2	Schematic A5, Store 2 assembly		5-21

A6 Buffer Assembly Package

Figure	A6-1	Component location, A6	Page	5-22
	A6-2	Schematic A6, Buffer assembly		5-23

A7 Switch Card Assembly Package

Table	A7-1	Component identification grid, A7	Page	5-25
Figure	A7-1	Component location, A7		5-24
	A7-2	Schematic A7, Switch Card assembly		5-25

A8 Hybrid Multiplier Assembly Package

Table	A8-1	Component identification grid, A8	Page	5-27
Figure	A8-1	Component location, A8		5-26
	A8-2	Schematic A8, Hybrid Multiplier assembly		5-27

A16 Deflection Amplifiers Assembly Package

Table	A16-1 Component identification grid, A16	Page 5-51
Figure	A16-1 Component location, A16	5-50
	A16-2 Schematic A16 (part 1), Deflection Amplifiers assembly	5-51
	A16-3 Schematic A16 (part 2), Deflection Amplifiers assembly	5-53

A17 High Voltage Power Supply Assembly Package

Table	A17-1 Component identification grid, A17	Page 5-55
Figure	A17-1 Component location, A17	5-54
	A17-2 Schematic A17, High Voltage Power Supply assembly	5-55

A18 Range Indicator Assembly

Table	A18-1 LED Truth Table	Page 5-57
Figure	A18-1 Component location, A18	5-56
	A18-2 Schematic A18, Range Indicator assembly	5-57

A19 Range Units Assembly Package

Figure	A19-1 Component location, A19	Page 5-56
	A19-2 Schematic A19, Range Units assembly	5-57

A20 Storage Assembly Package

Table	A20-1 Component identification grid, A20	Page 5-59
Figure	A20-1 Component location, A20	5-58
	A20-2 Schematic A20, Storage assembly	5-59



Figure 1-1 Model 3720A Spectrum Display

SECTION I INTRODUCTION

1-1 OPERATING INSTRUCTIONS

1-2 Detailed operating instructions are contained in the 3720A Operating Manual but, for convenience, descriptions of the controls, indicators and connectors on the front and rear panels of the 3720A are included in this section.

1-3 GENERAL SERVICING INSTRUCTIONS

1-4 When servicing the 3721A/3720A System, have the 3720A Spectrum Display Operating Manual (*hp* Part No. 03720-95000) available for reference.

1-5 Remember, when servicing the 3721A/3720A System, that a high intensity CRT display on the 3720A over an extended period of time may cause burn damage to the storage mesh or phosphors of the CRT.

1-6 The storage CRT in the 3720A is mechanically delicate and is *easily damaged* by *violent movement* or by *being inverted*. To prevent accidental damage in use, remember the following points when handling the 3720A:

- a. Do not tilt the 3720A onto its *front* panel.
- b. Do not subject the 3720A to violent movement.

Table 1-1 Accessories furnished with 3720A

Accessory	<i>hp</i> Part Number
Detachable Power Cord	Various
Rack Mounting Kit	5060-8742
Servicing Extender Board	03720-70021
3721A/3720A Interface Accessory	15549A
Trimming Tool	8730-0013
Operating Manual	03720-95000
Service Manual	03720-95001

WWW.HPARCHIVE.COM
For Free Distribution Only

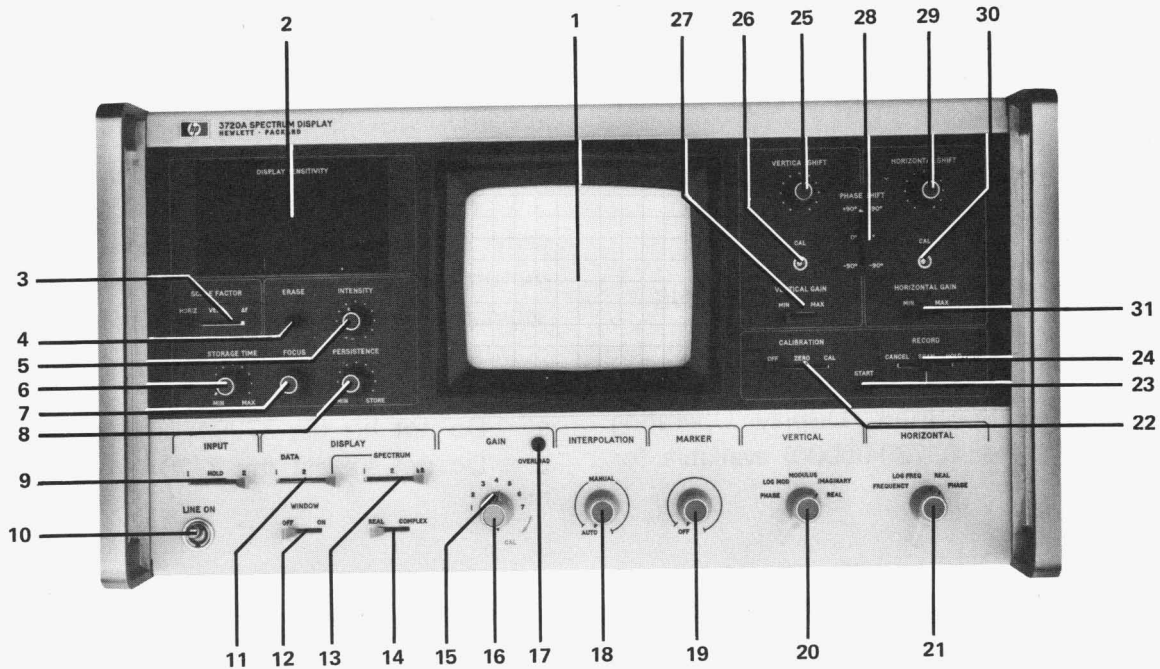

- | | |
|---|---|
| <p>1. DISPLAY: 8 by 10 division CRT, with graticule calibrated in one division squares. Major axes calibrated in 0.2 division intervals. 1 division = 0.95cm.</p> <p>2. DISPLAY SENSITIVITY: illuminated digital readout. Scales the horizontal and vertical axes and the frequency interval, Δf, as selected by Scale Factor switch.</p> <p>3. SCALE FACTOR: lever switch. Selects axis calibration to be presented on the Display Sensitivity panel.</p> <p>4. ERASE: pushbutton. Eradicates all traces displayed on storage CRT screen, when not in STORE mode.</p> <p>5. INTENSITY: potentiometer. Controls brightness of CRT beam.</p> | <p>6. STORAGE TIME: potentiometer. Varies the time any display is stored, when in STORE mode.</p> <p>7. FOCUS: potentiometer. Adjusts sharpness of CRT beam.</p> <p>8. PERSISTENCE: potentiometer. Controls duration of written trace, when not in STORE mode. Fully clockwise position selects STORE mode.</p> <p>9. INPUT: lever switch. Routes data from the 3721A into Store 1 or 2 as selected. In HOLD position retains data in stores.</p> <p>10. LINE-ON: toggle switch. Controls ac supply to the instrument.</p> |
|---|---|

Figure 1-2 Front panel controls and indicators

11. **DATA:** lever switch. In positions 1 or 2 displays contents of respective store on CRT. In extreme right-hand position transfers control to SPECTRUM switch.
12. **WINDOW:** lever switch. ON position — applies a triangular window to input data. OFF position — natural window occurs.
13. **SPECTRUM:** lever switch. Controls choice of store contents to be transformed.
14. **REAL/COMPLEX:** lever switch.
REAL — calculates cosine components only.
COMPLEX — calculates cosine and sine components.
15. **GAIN:** rotary switch. Selects gain of integrator.
16. **GAIN VERNIER:** potentiometer. Provides continuous gain adjustment between calibrated steps. In CAL, gain selected by GAIN switch.
17. **OVERLOAD:** lamp. Indicates if integrator becomes overloaded at any time during processing.
18. **INTERPOLATION:** potentiometer. In the MANUAL mode fractionally alters each of the 100 frequencies at which the transform is computed (up to Δf max). In AUTO 10 equally spaced display points are produced in each frequency interval Δf .
19. **MARKER:** potentiometer. Puts a marker on any point of the displayed function.
20. **VERTICAL:** rotary switch. Selects function to be presented on vertical axis of CRT.
21. **HORIZONTAL:** rotary switch. Selects function to be presented on horizontal axis of CRT. Used together, controls 20 and 21 enable the user to select the presentation format of the display.
22. **CALIBRATION** lever switch. Allows external X-Y Recorder plot size to be set.
23. **START:** pushbutton. Initiates a single sweep of the pen across the X-Y Recorder chart.
24. **RECORD:** lever switch. Controls outputting of trace on to X-Y Recorder.
25. **HORIZONTAL SHIFT:** potentiometer. Moves trace horizontally on CRT.
26. **CAL:** potentiometer. Adjusts horizontal size of display.
27. **HORIZONTAL GAIN:** lever switch. Magnifies horizontal axis of displayed trace by a factor of 2.
28. **PHASE SHIFT:** lever switch. Adds 0, $+90^\circ$, or -90° phase shift to any display axis representing phase information.
29. **VERTICAL SHIFT:** potentiometer. Moves trace vertically on CRT screen.
30. **CAL:** potentiometer. Adjusts vertical size of display.
31. **VERTICAL GAIN:** lever switch. Provides magnification of vertical axis of displayed trace by a factor of 2.

Figure 1-2 Front panel controls and indicators (continued)

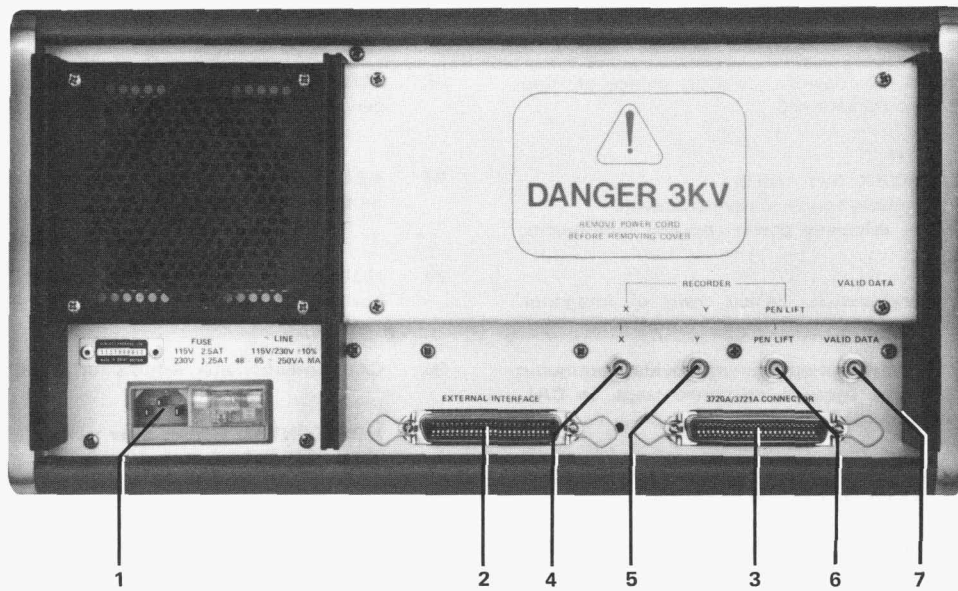

1. **POWER MODULE:** contains ac line socket, fuse, and voltage selector switch.

AC Line. 115/230V, $\pm 10\%$, 48 to 65Hz, 250VA.

Fuse. 115V -2.5AT, 230V -1.25AT.
Clip-in fuse. Cannot be changed without first removing power cable.

Selector. Lever switch, 115V or 230V line voltage selector. Cannot be changed without first removing power cable.

2. **EXTERNAL INTERFACE:** 50-contact connector. Duplicates 3721A Data Interface rear panel connector.

3. **3720A/3721A CONNECTOR:** 50-contact connector. Input socket for data from 3721A.

4. **X-RECORDER:** BNC connector. Output to horizontal axis of X-Y Recorder.

5. **Y-RECORDER:** BNC connector. Output to vertical axis of X-Y Recorder.

6. **PEN LIFT:** BNC connector. Provides control signal for pen of an X-Y Recorder with remote pen control facility.

7. **VALID DATA:** BNC connector. Provides a signal to indicate that valid data is present at X and Y Recorder output connectors.

NOTE: \sim denotes alternating current (ac).

Figure 1-3 Rear panel controls and connectors

SECTION II

GENERAL MAINTENANCE

2-1 INTRODUCTION

2-2 This section contains information on Identification, Instrument Dismantling and Repair Procedures for the 3720A.

2-3 IDENTIFICATION

2-4 Assembly Identification

2-5 Table 2-1 lists the designator, title and *hp* Part Number of all assemblies in the 3720A Spectrum Display. (Assembly is abbreviated to Assy in this Table).

2-6 Assembly Connection Identification

2-7 Throughout this manual connections to printed circuit assemblies are referred to by an abbreviated form. For example, the connection to pin M on A5 assembly is written as A5(M).

2-8 Integrated Circuit Identification

2-9 Digital integrated circuits are referenced by the physical location of each package (MC prefix) on the circuit board, and by their function in the circuit (G, FF, etc, as applicable).

Table 2-1 3720A Assemblies

Assembly Designator	Title	<i>hp</i> Part Number
A1	Not Assigned	—
A2	Mantissa Range Assy	03720-70002
A3	Decade Range Assy	03720-70003
A4	Store 1 Assy	03720-70004
A5	Store 2 Assy	03720-70005
A6	Buffer Assy	03720-70006
A7	Switch Card Assy	03720-70007
A8	Hybrid Multiplier Assy	03720-70008
A9	Window Multiplier Assy	07320-70009
A10	Integrator Assy	03720-70010
A11	Polar Converter Assy	03720-70011
A12	Low Voltage Power Supply Assy	03720-70012
A13	Control Logic Assy	03720-70013
A14	Triangle Wave Generator Assy	03720-70014
A15	Sine Shaper Assy	03720-70015
A16	Deflection Amplifiers Assy	03720-70016
A17	High Voltage Power Supply Assy	03720-70017
A18	Range Indicator Assy	03720-70018
A19	Range Units Assy	03720-70019
A20	Storage Assy	03720-70020

2-10 The MC number gives the physical location of each package in the form of a grid reference.

2-11 With the printed circuit board held component side uppermost, and tongued connector nearest, numbering of the rows and columns of integrated circuits starts from the top left hand corner of the board. The first figure following the MC prefix gives the row and the second gives the column. For example, MC52 will lie in the 5th row down and the 2nd column across, whilst MC103 will be in the 10th row and 3rd column.

2-12 The second method of identification of the individual 'component blocks' helps the circuit description and signal flow indication.

2-13 Each 'block' is given a prefix according to its function (see Table 2-2 for a full list) and a number indicating its position on the schematic diagram, in the same manner as resistors, capacitors, etc, are referenced.

Table 2-2 Digital integrated circuit abbreviations

Abbreviation	Function
B	Buffer
DD	Decade Divider
FF	Flip-flop
G	Gate
IG	Inverter Gate
MS	Monostable
SR	Shift Register

2-14 All IC leads are referred to in the same way as assembly connections. For example, lead 12 on integrated circuit MC25, on A5 assembly, is referred to as A5MC25(12). Similarly when describing schematics, lead 6 on Flip-flop 9 on assembly A2 would be referenced A2FF9(6).

2-15 INSTRUMENT DISMANTLING

DANGER

115/230V AC AND +158V DC SUPPLY WIRES ARE EXPOSED WHEN ANY OF THE INSTRUMENT COVERS ARE REMOVED. USE EXTREME CAUTION DURING TROUBLESHOOTING, ADJUSTMENT OR REPAIR. AVOID DAMAGE TO THE INSTRUMENT BY DISCONNECTING THE POWER CABLE BEFORE REMOVING OR REPLACING COVERS, ASSEMBLIES OR COMPONENTS.

2-16 Removing Top and Bottom Covers

1. Remove the four cross-head screws holding the cover in position.
2. Slide the cover about 1in (2.5cm) to the rear and lift clear.

NOTE: It is not necessary to remove the feet or the tilt stand from the bottom cover before removal.

2-17 Removing Side Covers

1. Remove the four cross-head screws securing each cover.
2. Lift cover clear.

2-18 Front Panel Access

1. Remove the *top* and *bottom* covers from the instrument.
2. Release the two screws securing the A1/A11 retaining strip and lift this strip clear.
3. Remove assemblies A2 to A11 inclusive.
4. Release the two screws at the base of each of the right hand and left hand board guides.
5. Withdraw the board guides to give access to the rear of the front panel.
6. Re-assembly is a reversal of the above procedure.

2-19 MAINTENANCE

CAUTION

When handling the 3720A do not tilt the instrument onto its front panel.

2-20 Locations of dc Power Supply Fuses

2-21 Access to the +158V, +50V, +15V, +5V, -15V, -22V and -50V power supply fuses is gained by removing the *bottom* cover of the instrument.

2-22 The +12.6V power supply fuse is on the A20 Storage assembly. Access to the fuse is gained by removing the *top* cover of the 3720A.

2-23 Replacement of Display Sensitivity Lamps

2-24 The lamps are mounted on the A18 and A19 assemblies. To replace the lamps the A18/A19 housing assembly must be removed from the instrument and then dismantled.

2-25 Removal of A18/A19 Housing Assembly

1. Remove the *top* cover, *left* side cover and fluted aluminium plate from the instrument. Note that the fluted aluminium plate is self-adhesive.
2. Release the two screws securing the A1/A11 retaining strip and lift this strip clear.
3. Remove assemblies A2 to A6 inclusive.
4. Release the two screws at the base of the left hand board guide and withdraw the board guide.
5. Remove the left hand board guide support by releasing the three screws A shown in Figure 2-1.

6. Remove the four nuts holding the A18/A19 housing assembly to the front panel. If necessary, gently move the wiring to gain access to the nuts.
7. Release screw B shown in Figure 2-1.
8. Holding the A18/A19 housing assembly with one hand, gently press the Display Sensitivity panel on the front of the instrument with the other hand to release the assembly.
9. Replacement of the A18/A19 housing assembly is a reversal of the above procedure.

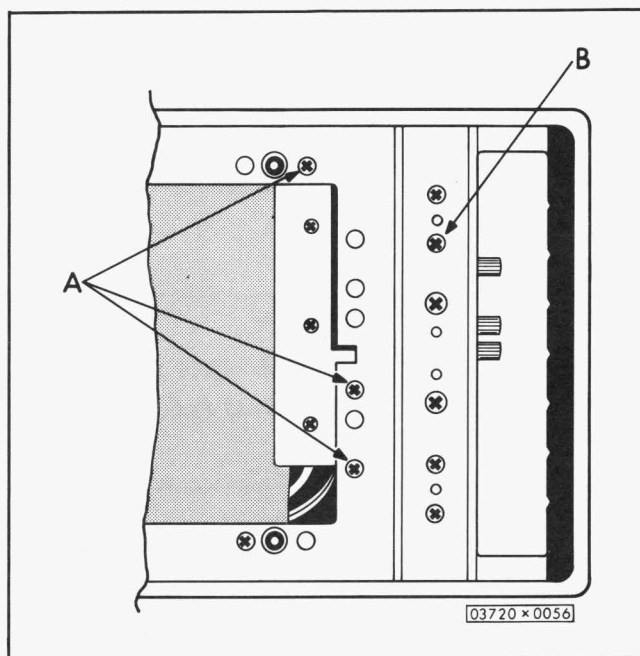

Figure 2-1 A18/A19 Housing assembly retaining screws

2-26 Dismantling the A18/A19 Assembly

1. Remove the A18/A19 housing assembly as detailed in Paragraph 2-25.
2. Release the two screws holding the range units lamp separator in place.
3. *Slide* the separator away from the assembly.

CAUTION

If the separator is forced sideways the units lamps will be damaged.

4. Pull out A18 and/or A19 assemblies as required and disconnect the A18/A19 interconnecting cables.
5. Renew the faulty lamps.
6. Re-assembly is a reversal of the above procedure.

2-27 Cleaning The Air Filter

2-28 The air filter on the fan cover of the 3720A should be removed periodically for cleaning. Four screws secure the fan cover to the back panel.

2-29 Cathode Ray Tube Removal/Replacement

DANGER
WHEN HANDLING THE CRT ALWAYS WEAR GOGGLES AND GLOVES. HANDLE WITH EXTREME CARE.

1. Disconnect the power cable from the 3720A
2. Remove the *top* cover from the instrument.
3. Remove the back panel high voltage cover.
4. Unplug the CRT socket.
5. Release the two screws holding A20 in place and lift out A20.
6. Unplug the wires connected to the neck of the CRT. The colours of the wires are shown in Figure 2-2.
7. Remove A20 support block by releasing the two screws which hold it in place.
8. Release the two screws securing the A1/A11 retaining strip and lift this strip clear.
9. Remove assemblies A2 to A6 inclusive.
10. Remove the two screws holding the high voltage connector A55J1 in place. Disconnect the flexible wiring from this connector.
11. Unplug the wire from the collimator connector on the side of the CRT.

12. Remove the black light shield surrounding the CRT screen by gently squeezing it at the top centre and bottom centre and pulling clear.
13. Unscrew and remove the bezel.
14. Slacken the clamp on the rear of the CRT neck.
15. Holding the screen of CRT with one hand, gently press the rear of the tube with the other hand and slide the CRT forward and out.

NOTE: To prevent accidental damage to the storage mesh **DO NOT TILT THE CRT FACE DOWNWARDS.**

16. Re-assembly is a reversal of the above procedure.

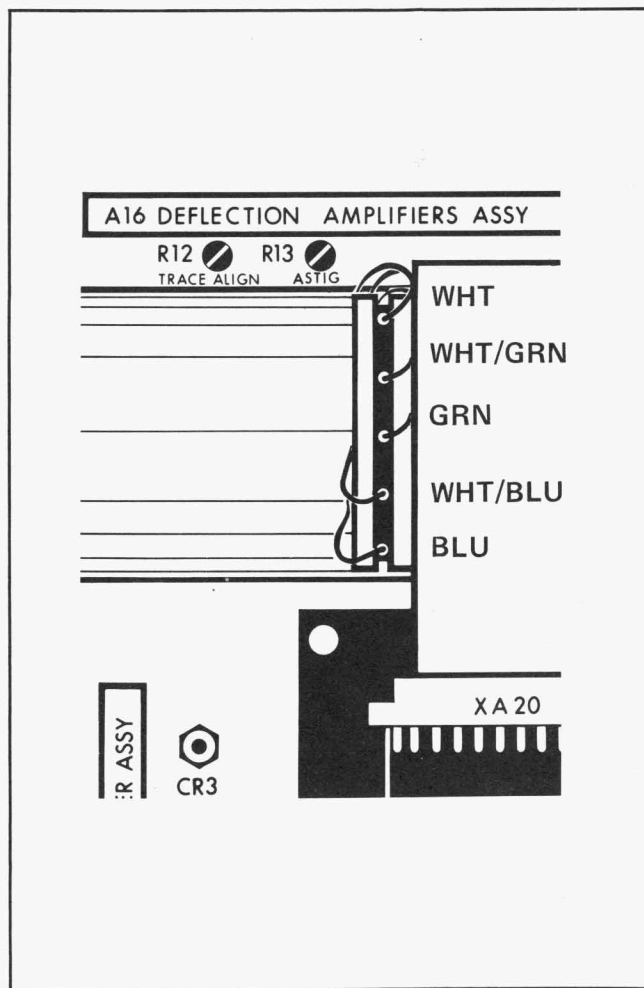

Figure 2-2 CRT neck connections

2-30 Line Transformer Removal/Replacement

1. Tilt the 3720A onto its right hand side.
2. Remove the *top* and *bottom* covers from the instrument.
3. Release the two screws holding A20 in place and lift out A20.
4. Remove the back panel high voltage cover.
5. Remove the internal high voltage cover.
6. Unplug the five wires from A17 and then remove A17.
7. Remove XA20 mounting plate and pull it gently to the side.
8. Note the wire colours against the corresponding pin numbers on the top and bottom of the line transformer and then unsolder the connections.
9. Remove the four screws holding the transformer in position. Retain the underside nuts and safety mouldings and pull the transformer out through the top of the instrument.
10. Re-assembly is a reversal of the above procedure.

2-31 Chassis Mounted Transistors Plate Removal/Replacement

1. Remove the *top* cover and *right* side cover from the instrument.
2. Release the two screws securing the A12/A16 retaining strip and lift this strip clear.
3. Remove assemblies A12 to A16 inclusive.
4. Release the two screws at the bottom of the transistor plate.
5. Withdraw the plate.
6. Renew the faulty transistors as necessary.
7. Re-assembly is a reversal of the above procedure.

2-32 High Voltage Tripler Assembly Removal/Replacement

1. Remove the *top* cover from the instrument.

2. Remove the internal high voltage cover.
3. Remove the rear panel high voltage cover.
4. Unplug the five wires from A17 and then remove A17.
5. Unsolder the black and grey wires from the ground tag.
6. Release the two screws holding A20 in place and lift out A20.
7. Remove XA20 mounting plate.
8. Release the two screws securing the A1/A11 retaining strip and lift this strip clear.
9. Remove assemblies A2 to A6 inclusive.
10. Remove A20 support block. Two screws hold it in place.
11. Remove the two screws holding the high voltage connector A55J1 in place. Disconnect the flexible wiring from this connector.
12. Unsolder the wires from XA(20(L) and XA20(N) after noting their colours.
13. Remove the wires from the grommet.
14. Lift out the high voltage tripler assembly.
15. Re-assembly is a reversal of the above procedure.

2-33 REPAIR PROCEDURES

2-34 Etched Circuits

2-35 The etched circuit boards in the Spectrum Display are of the plated-through type, consisting of metallic conductors bonded to both sides of the insulating material. The metallic conductors are extended through the component mounting holes by a plating process. Solder connection can be made from either side of the board with equally good results. Following are recommendations and precautions pertinent to etched circuit repair work:

- a. Avoid unnecessary component substitution; it can result in damage to the circuit board and/or adjacent components.

b. Do not use a high-power soldering iron on etched circuit boards. Excessive heat may lift a conductor or damage the board. A 40 watt soldering iron is sufficient.

c. Use a suction device, eg, Soldapult, or wooden toothpick to remove solder from component mounting holes. Care must be taken when clearing out component mounting holes; never use sharp metal objects, such as an awl or a twist-drill, which could damage the plated-through conductor.

d. After soldering, remove excess flux from the soldered areas with a soap and water solution.

e. When removing a multiple connection component, such as an integrated circuit, loosen it gradually, using a gentle side-to-side motion, to avoid damage to the plated-through conductors.

2-36 Integrated Circuit Removal/Replacement

2-37 There are three recommended methods of

removing integrated circuit packages from a printed circuit board:

a. **Solder Gobbler.** This is the best method. Solder is removed from the board by a soldering iron with a hollow tip connected to a vacuum source. This permits an IC to be removed intact so that it may be replaced if an error has been made in diagnosis.

b. **Desoldering Tool.** (Soldapult — *hp* Part No. 8690-0060). This method is recommended if a vacuum operated Solder Gobbler is not available. Remove the solder from each lead by using the soldering iron and the desoldering tool together.

c. **Clip Out.** This is the least satisfactory of the three methods. Clip the leads as close to the case as possible. With a soldering iron and long nose pliers carefully remove the leads from each hole.

SECTION III REPLACEABLE PARTS

3-1 INTRODUCTION

3-2 This section contains information for ordering replaceable parts. Table 3-1 lists parts in alphabetical order of their reference designators and gives the following information for each part:

- a. Hewlett-Packard stock number.
- b. Description (abbreviations given in Paragraphs 3-7, 3-8 and 3-9).
- c. Total quantities of each part used in the instrument (refer to TQ column).
- d. Manufacturer and Manufacturer's part number (Code List of Manufacturers given in Table 3-2).

3-3 ORDERING INFORMATION

3-4 To order a replacement part, address the order or enquiry to your local Hewlett-Packard Sales and Service Office (addresses are listed at the rear of this manual).

3-5 Specify the following information for each part:

- a. Model and full serial number of instrument.
- b. Hewlett-Packard stock number.
- c. Circuit reference designator.
- d. Description.

3-6 To order a part not listed in the tables, give a complete description of the part including its function and location in the instrument.

3-7 REFERENCE DESIGNATORS

A	= assembly	L	= inductor	S	= switch
C	= capacitor	MC	= micro circuit	SR	= shift register
CR	= diode	MP	= metal work/ miscellaneous part	T	= transformer
DS	= lamp	P	= plug (male)	XA	= printed circuit board edge connector
F	= fuse	Q	= transistor		
IC	= integrated circuit	R	= resistor		
J	= connector (female)				

3-8 LIST OF ABBREVIATIONS

A	= ampere	INCD	= incandescent	QUAD	= quadruple
AC	= alternating current	IND	= inductor	REC	= rectifier
AL	= aluminium	INV	= invert	RH	= right hand side
AMPL	= amplifier	I/P	= input	RND	= round
ASSY	= assembly	K	= kilo (10^3)	RTRY	= rotary
BD	= board	LED	= light emitting diode	SI	= silicon
BHD	= bulkhead	LH	= left hand side	SPDT	= single pole, double throw
BKDN	= breakdown	LIN	= linear	SPST	= single pole, single throw
CBL	= cable	LVR	= lever	SW	= switch
COAX	= coaxial	M	= mega (10^6)	T	= throw
COMP	= compensated	MA	= milli ampere (10^{-3})	TEMP	= temperature
CONCEN	= concentric	MH	= milli henry (10^{-3})	TGL	= toggle
CONN	= connector	MTG	= mounting	TQ*	= total quantity
CONT	= controlled	MW	= milli watt (10^{-3})	UF	= micro farad (10^{-6})
CRT	= cathode ray tube	NAND	= not and	V	= volt
DIO	= diode	NOR	= not or	VAR	= variable
DPDT	= double pole, double throw	NPN	= negative-positive-negative	W	= watt
FET	= field effect transistor	NSR	= not separately replaceable	WVDC	= working voltage direct current
FXD	= fixed	OPER	= operational	XFMR	= transformer
GE	= germanium	PC	= printed circuit	XR	= expander
HV	= high voltage	PF	= pico farad (10^{-12})	XSTR	= transistor
HS	= high speed	PIV	= peak inverse volts		
IC	= integrated circuit	PNP	= positive-negative-positive		

*except for those components with #TQ after the description. In these cases multiply the number in the total quantity column by the number after # TQ for true quantity.

3-9 COLOUR ABBREVIATIONS

BLK	= black (0)	YEL	= yellow (4)	GRY	= grey (8)
BRN	= brown (1)	GRN	= green (5)	WHT	= white (9)
RED	= red (2)	BLU	= blue (6)	SILV	= silver
ORN	= orange (3)	VIO	= violet (7)		

Table 3-1 Replaceable Parts

Ref Desig	HP Part No	TQ	Description	Mfr	Mfr Part No
ACCESSORIES					
	8120-1351	1	CABLE POWER DETACHABLE #UK#	E0007	
	8120-1348	1	#NEMA#	E0007	
	8120-1689	1	#SCHUKO#	E0007	
	8120-1369	1	#AUST#	E0007	
	03720-95000	1	MANUAL OPERATING	E0007	
	03720-95001	1	MANUAL SERVICE	E0007	
	03720-70021	1	BOARD EXTENDER SERVICING	E0007	
	5060-8742	1	KIT RACK MOUNTING	E0007	
	15549A	1	ACCESSORY 3721A/3720A INTERFACE	E0007	
PACKING MATERIALS					
	9211-1356	1	CARTON	E0007	
	9220-1546	1	PAD FRONT	E0007	
	9220-1551	1	ASSY CARTON FLOATER	E0007	
	9220-1547	1	PAD BOTTOM	E0007	
	9222-0325	1	BAG POLYTHENE	E0007	
	9220-1549	1	PAD DOUBLE CELL	E0007	
A1			NOT ASSIGNED		
A2	03720-70002	1	ASSY MANTISSA RANGE	E0007	
A3	03720-70003	1	ASSY DECADE RANGE	E0007	
A4	03720-70004	1	ASSY STORE 1	E0007	
A5	03720-70005	1	ASSY STORE 2	E0007	
A6	03720-70006	1	ASSY BUFFER	E0007	
A7	03720-70007	1	ASSY SWITCH CARD	E0007	
A8	03720-70008	1	ASSY HYBRID MULTIPLIER	E0007	
A9	03720-70009	1	ASSY WINDOW MULTIPLIER	E0007	
A10	03720-70010	1	ASSY INTEGRATOR	E0007	
A11	03720-70011	1	ASSY POLAR CONVERTER	F0007	
A12	03720-70012	1	ASSY LOW VOLTAGE POWER SUPPLY	E0007	
A13	03720-70013	1	ASSY CONTRL LOGIC	E0007	
A14	03720-70014	1	ASSY TRIANGLE WAVE GENERATOR	E0007	
A15	03720-70015	1	ASSY SINE SHAPER	E0007	
A16	03720-70016	1	ASSY DEFLECTION AMPLIFIERS	E0007	
A17	03720-70017	1	ASSY HIGH VOLTAGE POWER SUPPLY	E0007	
A18	03720-70018	1	ASSY RANGE INDICATOR	E0007	
A19	03720-70019	1	ASSY RANGE UNITS	E0007	
A20	03720-70020	1	ASSY STORAGE	E0007	
A41	03720-70041	1	ASSY CBL HARNESS MAIN	F0007	
A42	03720-70042	1	ASSY CBL HARNESS HV	E0007	
A43	03720-70043	1	ASSY CBL HARNESS PRIMARY POWER	E0007	
A44	03720-70044	1	ASSY CBL HARNESS FRONT PANEL	E0007	
A45	03720-70045	1	ASSY CBL HARNESS LH	F0007	
A46	03720-70046	1	ASSY CBL HARNESS RH	E0007	
A47	03720-70047	1	ASSY CBL HARNESS INTERCONNECTIONS	E0007	
A48	03720-70048	1	ASSY CBL HARNESS SECONDARY POWER	E0007	
A49	03720-70049	1	ASSY CBL HARNESS POWER XSTR	E0007	
A50	03720-70050	1	ASSY CBL HARNESS POWER XFMR	E0007	
A51	03720-70051	1	ASSY CBL HARNESS DISPLAY SENSITIVITY	E0007	

Abbreviations are listed in the introduction to this section

Table 3-1 Replaceable Parts (continued)

Ref Desig	HP Part No	TQ	Description	Mfr	Mfr Part No
A52	03720-70052	1	ASSY CBL A18/A19-P1	E0007	
A53	03720-70053	1	ASSY CBL A18/A19-P2	E0007	
A55	03720-70055	1	ASSY HIGH VOLTAGE TRIPLER	E0007	
B1	3160-0209	1	FAN TUBEAXIAL	23936	8500
	03720-70033	1	ASSY FAN FILTER	E0007	
	03720-30131	1	SPACER FAN #TQ 4#	E0007	
C1	0180-0024	1	C FXD 40UF +50-10% 450WVDC	56289	D32441DFB
C2	0180-0046	2	C FXD 600UF +75-10% 200WVDC	56289	D32569DFP
C3	0180-0204	2	C FXD 2800UF +100-10% 40WVDC	56289	D37694DFP
C4	0180-0213	1	C FXD 5000UF +50-10% 25WVDC	09684	505
C5	0180-0204		C FXD 2800UF +100-10% 40WVDC	56289	D37694DFP
C6	1520-0001	3	PLATE MTG	56137	X-831
	0180-0369	1	C FXD 2800UF +75-10% 60WVDC	56289	D39823DFP
	1520-0001		PLATE MTG	56137	X-831
C7	0180-0046		C FXD 600UF +75-10% 200WVDC	56289	D32569DFP
	1520-0001		PLATE MTG	56137	X-831
C8	0180-0116	34	C FXD 6.8UF 10% 35WVDC	56289	150D685X9035B2-DYS
CR1	1901-0495	4	DIO SI 50PIV 12A	E0007	
	1200-0080	5	INSULATOR DIO #TQ 2#	76530	294834
CR2	1901-0495		DIO SI 50PIV 12A	E0007	
	1200-0080		INSULATOR DIO #TQ 2#	76530	294834
CR3	1901-0495		DIO SI 50PIV 12A	E0007	
	1200-0080		INSULATOR DIO #TQ 2#	76530	294834
CR4	1901-0495		DIO SI 50PIV 12A	E0007	
	1200-0080		INSULATOR DIO #TQ 2#	76530	294834
CR5	1902-1201	1	DIO BKDN 6.2V 5% 10W	04713	IN3998A
	1200-0080		INSULATOR DIO #TQ 2#	76530	294834
CR6	1901-0040	140	DIO SI	12065	SG5050
DS1	5082-4417	1	LAMP WHT #OVERLOAD#	E0007	
	5082-4409	1	MOUNTING CLIP	E0007	
F1	2110-0305	1	FUSE SLOW BLOW 1.25AT 250V	71400	MDX-1-1/4A
			#230V LINE#		
	2110-0380	1	FUSE SLOW BLOW 2.5AT 250V	71400	MDA2-1/2
			#115V LINE#		
F2	2110-0311	1	FUSE SLOW BLOW 0.062AT 250V	71400	MDL-1/16
F3	2110-0235	2	FUSE SLOW BLOW 0.2AT 250V	71400	MDL-8
F4	2110-0303	1	FUSE SLOW BLOW 2AT 250V	71400	MDX-2A
F5	2110-0383	1	FUSE SLOW BLOW 8AT 250V	71400	MDA8
F6	2110-0202	1	FUSE SLOW BLOW 0.5AT 250V	71400	MDL-1/2
F7	2110-0235		FUSE SLOW BLOW 0.2AT 250V	71400	MDL-8
F8	2110-0320	1	FUSE SLOW BLOW 0.15AT 250V	71400	MDL-15/100
J1	5060-1188	1	LINE MODULE #AC POWER INPUT#	E0007	
	7124-1928	1	LABEL 115-230V	E0007	
J2	1251-0087	2	CONN MULTI BHD MTG 50-WAY	02660	57-40500-375
			#EXTERNAL INTERFACE#		
J3	1251-0087		CONN MULTI BHD MTG 50-WAY	02660	57-40500-375
			#3720A/3721A CONNECTOR#		
J4	1250-0083	4	CONN COAX BHD MTG BNC #X RECORDER#	95712	30624-1
J5	1250-0083		CONN COAX BHD MTG BNC #Y RECORDER#	95712	30624-1
J6	1250-0083		CONN COAX BHD MTG BNC #PEN LIFT#	95712	30624-1
J7	1250-0083		CONN COAX BHD MTG BNC #VALID DATA#	95712	30624-1
L1	01200-66001	1	COIL TRACE ALIGN	E0007	
MP1	03720-10013	1	PANEL FRONT	E0007	

Abbreviations are listed in the introduction to this section

Table 3-1 Replaceable Parts (continued)

Ref Desig	HP Part No	TQ	Description	Mfr	Mfr Part No
MP2	03720-30136	1	WINDOW DISPLAY SENSITIVITY	E0007	
MP3	03720-30142	1	MASTER DISPLAY SENSITIVITY	E0007	
MP4	5020-0476	1	BEZEL	28480	
MP5	5040-0508	1	LIGHT SHIELD BLACK	E0007	
MP6	7120-0995	1	PLATE CAUTION	E0007	
MP7	03720-10001	1	PANEL REAR	E0007	
MP8	03720-10006	1	COVER PANEL REAR	E0007	
MP9	03720-10007	1	COVER FAN	E0007	
MP10	03720-30130	1	FOOT PANEL REAR #TQ 3#	E0007	
MP11	5060-8707	1	COVER TOP	E0007	
MP12	5060-8731	1	COVER BOTTOM	E0007	
MP13	5060-0767	1	FOOT #TQ 5#	E0007	
MP14	1490-0030	1	STAND TILT	91260	08D
MP15	5060-0736	1	FRAME SIDE #TQ 2#	28480	
MP16	5000-8727	1	COVER SIDE #TQ 2#	E0007	
MP17	5000-0053	1	PLATE FLUTED AL #TQ 2#	28480	
MP18	5060-0222	1	HANDLE ASSY SIDE #TQ 2#	28480	
MP19	5060-8735	1	RETAINER HANDLE #TQ 2#	E0007	
MP20	03720-10008	1	COVER HV ASSY	E0007	
MP21	03720-10025	1	PLATE POWER XSTR	E0007	
MP22	03720-70037	1	ASSY HOUSING A18/A19	E0007	
MP23	03720-30137	1	SEPARATOR RANGE UNITS LAMPS	E0007	
MP24	03720-30138	1	BLOCK X10 MULTIPLIER	E0007	
MP25	03720-10033	1	DIFFUSER X10 MULTIPLIER	E0007	
MP26	03720-30141	1	MASTER X10 MULTIPLIER	E0007	
MP27	03720-70032	1	STRIP RETAINING A1/A11	E0007	
MP28	03720-70031	1	STRIP RETAINING A12/A16	E0007	
MP29	03720-30139	1	BLOCK A20 SUPPORT	E0007	
MP30	03720-10019	1	GUIDE BOARD RH	E0007	
MP31	03720-30132	2	SUPPORT GUIDE BOARD	E0007	
MP32	03720-10018	1	GUIDE BOARD LH	E0007	
MP33	03720-30132	1	SUPPORT GUIDE BOARD	E0007	
MP34	03720-10031	1	PLATE SUPPORT	E0007	
Q1	1854-0063	6	XSTR SI NPN #+50V#	02735	2N3055
	1200-0041	6	MOUNTING BASE XSTR	71785	133-32-10-013
	1200-0043	6	INSULATOR XSTR	76530	293011
Q2	1854-0063		XSTR SI NPN #+15V#	02735	2N3055
	1200-0041		MOUNTING BASE XSTR	71785	133-32-10-013
	1200-0043		INSULATOR XSTR	76530	293011
Q3	1854-0063		XSTR SI NPN #+5V#	02735	2N3055
	1200-0041		MOUNTING BASE XSTR	71785	133-32-10-013
	1200-0043		INSULATOR XSTR	76530	293011
Q4	1854-0063		XSTR SI NPN #-15V#	02735	2N3055
	1200-0041		MOUNTING BASE XSTR	71785	133-32-10-013
	1200-0043		INSULATOR XSTR	76530	293011
Q5	1854-0063		XSTR SI NPN #-22V#	02735	2N3055
	1200-0041		MOUNTING BASE XSTR	71785	133-32-10-013
	1200-0043		INSULATOR XSTR	76530	293011
Q6	1854-0063		XSTR SI NPN #-50V#	02735	2N3055
	1200-0041		MOUNTING BASE XSTR	71785	133-32-10-013
	1200-0043		INSULATOR XSTR	76530	293011
Q7	1854-0330	2	XSTR SI NPN #+158V#	04713	SJE901
	0340-0451	1	INSULATOR XSTR	04713	14B52600F03
Q8	1854-0320	1	XSTR SI NPN #+12.6V#	04713	SJE101
	0340-0469	1	INSULATOR XSTR	02375	DF103B

Abbreviations are listed in the introduction to this section

Table 3-1 Replaceable Parts (continued)

Ref Desig	HP Part No	TQ	Description	Mfr	Mfr Part No
R1	2100-2757	4	R VAR 5K OHM 20% 2W LIN #INTENSITY#	71450	551
	0370-1007	5	KNOB POINTER	14493	0370-1003
	2100-2751	1	R VAR 1M OHM 20% 2W LIN #STORAGE TIME	71450	551
	0370-1007		KNOB POINTER	14493	0370-1003
R3	2100-3236	1	R VAR 5M OHM 10% LIN #FOCUS#	11236	551
	0370-1003	1	KNOB RND	14493	0370-1003
	5040-0421	1	COVER INSULATING POTENTIOMETER	28480	
R4	2100-3237	1	R VAR 1M OHM LIN + SW SPST #S4#	01121	GS
			#PERSISTENCE#		
	0370-1007		KNOB POINTER	14493	0370-1003
R5	2100-3238	1	R VAR 1K OHM +SW SPST #S20# #GAIN#	01121	GS
R6	2100-3239	1	R VAR DUAL 10K OHM + SW SPST #S11#	01121	70
			#INTERPOLATION#		
	0370-1099	2	KNOB POINTER	28480	
R7	2100-2971	1	R VAR 2.5K OHM 10% 1W + SW DPST #S21#	20846	TYPE53
			#MARKER#		
	0370-1099		KNOB POINTER	28480	
R8	2100-2757		R VAR 5K OHM 20% 2W LIN #VERT SHIFT#	71450	551
	0370-1007		KNOB POINTER	14493	0370-1003
R9	2100-2758	2	R VAR 2.5K OHM 20% 2W LIN #CAL-VERT#	71450	551
	1490-0848	2	BUSHING POTENTIOMETER	E0007	
	0590-0043	2	PILLAR	E0007	
R10	2100-2757		R VAR 5K OHM 20% 2W LIN #HORIZ SHIFT#	71450	551
	0370-1007		KNOB POINTER	14493	0370-1003
R11	2100-2758		R VAR 2.5K OHM 20% 2W LIN #CAL-HORIZ#	71450	551
	1490-0848		BUSHING POTENTIOMETER	E0007	
	0590-0043		PILLAR	E0007	
R12	2100-2757		R VAR 5K OHM 20% 2W LIN #TRACE ALIGN#	71450	551
R13	2100-1530	1	R VAR 200K OHM 30% 1/5W LIN #ASTIG#	71450	70
R14	0698-3457	2	R FXD 316K OHM 1% 1/8W #C1#	19701	MF4CT-0
R15	0698-3162	7	R FXD 46.4K OHM 1% 1/8W #C2#	19701	MF4CT-0
R16	0757-0290	6	R FXD 6.19K OHM 1% 1/8W #C3#	75042	CEA
R17	0757-0728	1	R FXD 619 OHM 1% 1/4W #C4#	19701	MF52CT-0
R18	0757-0290		R FXD 6.19K OHM 1% 1/8W #C5#	75042	CEA
R19	0757-0290		R FXD 6.19K OHM 1% 1/8W #C6#	75042	CEA
R20	0698-3162		R FXD 46.4K OHM 1% 1/8W #C7#	19701	MF4CT-0
R21	0757-0280	82	R FXD 1K OHM 1% 1/8W	75042	CEAT-0
R22	0757-0280		R FXD 1K OHM 1% 1/8W	75042	CEAT-0
R23	0757-0280		R FXD 1K OHM 1% 1/8W	75042	CEAT-0
R24	0757-0424	2	R FXD 1.1K OHM 1% 1/8W	19701	MF4CT-0
R25	0698-5490	137	R FXD 2K OHM 1% 1/8W	91637	CMF-1/10-32T-2
R26	0698-5490		R FXD 2K OHM 1% 1/8W	91637	CMF-1/10-32T-2
R27	0698-5490		R FXD 2K OHM 1% 1/8W	91637	CMF-1/10-32T-2
S1	3101-0038	1	SW TGL DPDT #LINE#	04009	83054-H
S2	3100-0640	2	SW LVR 1 SECTION 3T #SCALE FACTOR#	76854	184
	0370-1810	6	KNOB LVR OLIVE BLK	14493	
S3	3101-0044	2	SW PUSHBUTTON SPST #ERASE#	81073	39-1ND
	5040-3017	2	PUSHBUTTON	E0007	
S4			PART OF R4		
S5	3100-0644	3	SW LVR 1 SECTION 3T #INPUT#	76854	184
	0370-0929	5	KNOB LEVER	14493	0370-0929
S6	3100-3044	1	SW LVR 1 SECTION 3T #DATA#	E0007	
	0370-0929		KNOB LEVER	14493	0370-0929
S7	3100-0644		SW LVR 1 SECTION 3T #SPECTRUM#	76854	184

Abbreviations are listed in the introduction to this section

Table 3-1 Replaceable Parts (continued)

Ref Desig	HP Part No	TQ	Description	Mfr	Mfr Part No
S8	0370-0929	3	KNOB LEVER	14493	0370-0929
	3100-0641		SW LVR SPDT #WINDOW#	76854	184
	0370-0929		KNOB LEVER	14493	0370-0929
S9	3100-0666	1	SW LVR ACTUATED RTRY DPDT #REAL/COMP#	28480	
	0370-0929	1	KNOB LEVER	14493	0370-0929
3100-3046	SW RTRY 2 SECTION 7T #GAIN#		E0007		
0370-1103	KNOB POINTER		14493	0370-1003	
S10	0370-1811	1	KNOB CONCEN INNER	E0007	
			PART OF R6		
S11					
S12	3100-3047	1	SW RTRY 2 SECTION 5T #VERTICAL#	E0007	
	0370-1107	2	KNOB	E0007	
S13	3100-3048	1	SW RTRY 1 SECTION 4T #HORIZONTAL#	E0007	
	0370-1107		KNOB	E0007	
S14	3100-0640		SW LVR 1 SECTION 3T #PHASE SHIFT#	76854	184
S15	0370-1810	1	KNOB LVR OLIVE BLK	14493	
	3100-0641		SW LVR SPDT #VERTICAL GAIN#	76854	184
0370-1810	KNOB LVR OLIVE BLK		14493		
S16	3100-0641		SW LVR SPDT #HORIZONTAL GAIN#	76854	184
	0370-1810		KNOB LVR OLIVE BLK	14493	
S17	3100-0644		SW LVR 1 SECTION 3T #CALIBRATION#	76854	184
S18	0370-1810	1	KNOB LVR OLIVE BLK	14493	
	3101-0044		SW PUSHBUTTON SPST #START#	81073	39-1N0
5040-3017	PUSHBUTTON		E0007		
S19	3100-0655		SW LVR 1 SECTION 3T #CONTROL#	E0007	
S20	0370-1810	1	KNOB LVR OLIVE BLK	14493	
			PART OF R5		
S21			PART OF R7		
T1	9100-0632	1	XFMR LINE	E0007	
	03721-50007	1	COVER LINE XFMR #TQ 2#	E0007	
V1	5083-2152	1	CRT STORAGE	E0007	
XA1	1251-0335	16	CONN MULTI BHD MTG 2X24-WAY PC BD	95238	K600-13-PCGD24
XA2	1251-0335		CONN MULTI BHD MTG 2X24-WAY PC BD	95238	K600-13-PCGD24
XA3	1251-0335		CONN MULTI BHD MTG 2X24-WAY PC BD	95238	K600-13-PCGD24
XA4	1251-0335		CONN MULTI BHD MTG 2X24-WAY PC BD	95238	K600-13-PCGD24
XA5	1251-0335		CONN MULTI BHD MTG 2X24-WAY PC BD	95238	K600-13-PCGD24
XA6	1251-0335		CONN MULTI BHD MTG 2X24-WAY PC BD	95238	K600-13-PCGD24
XA7	1251-0335		CONN MULTI BHD MTG 2X24-WAY PC BD	95238	K600-13-PCGD24
XA8	1251-0335		CONN MULTI BHD MTG 2X24-WAY PC BD	95238	K600-13-PCGD24
XA9	1251-0335		CONN MULTI BHD MTG 2X24-WAY PC BD	95238	K600-13-PCGD24
XA10	1251-0335		CONN MULTI BHD MTG 2X24-WAY PC BD	95238	K600-13-PCGD24
XA11	1251-0335		CONN MULTI BHD MTG 2X24-WAY PC BD	95238	K600-13-PCGD24
XA12	1251-0335		CONN MULTI BHD MTG 2X24-WAY PC BD	95238	K600-13-PCGD24
XA13	1251-0335		CONN MULTI BHD MTG 2X24-WAY PC BD	95238	K600-13-PCGD24
XA14	1251-0335		CONN MULTI BHD MTG 2X24-WAY PC BD	95238	K600-13-PCGD24
XA15	1251-0335		CONN MULTI BHD MTG 2X24-WAY PC BD	95238	K600-13-PCGD24
XA16	1251-0335		CONN MULTI BHD MTG 2X24-WAY PC BD	95238	K600-13-PCGD24
XA17	1251-0172	1	CONN MULTI BHD MTG 22-WAY	71785	250-22-30-210
XA18	1251-1190	3	CONN MULTI BHD MTG 2X12-WAY PC BD	71785	251-12-30-261
XA19	1251-1190		CONN MULTI BHD MTG 2X12-WAY PC BD	71785	251-12-30-261
XA20	1251-1190		CONN MULTI BHD MTG 2X12-WAY PC BD	71785	251-12-30-261
A2			MANTISSA RANGE ASSY		
	03720-30002	1	PC BD BLANK #NSR#	E0007	
	4040-0750	2	EXTRACTOR PC BD RED	14493	5040-5113

Abbreviations are listed in the introduction to this section

Table 3-1 Replaceable Parts (continued)

Ref Desig	HP Part No	TQ	Description	Mfr	Mfr Part No
	4040-0748	6	EXTRACTOR PC BD BLK	28480	5040-5111
	1490-0116	15	PIN GROOVE #TQ 2#	73957	GP24-063X250-12
A2C1	0180-0116		C FXD 6.8UF 10% 35WVDC	56289	150D685X9035B2-DYS
A2MC11	1820-0070	4	IC 8-I/P NAND GATE	E0001	SN4345
A2MC12	1820-0054	42	IC QUAD 2-I/P NAND GATE	E0001	SN4342
A2MC13	1820-0054		IC QUAD 2-I/P NAND GATE	E0001	SN4342
A2MC14	1820-0054		IC QUAD 2-I/P NAND GATE	E0001	SN4342
A2MC15	1820-0077	20	IC DUAL D-TYPE FLIP-FLUP	E0001	SN4354
A2MC16	1820-0328	26	IC QUAD 2-I/P NOR GATE	E0001	SN4467
A2MC17	1820-0068	14	IC TRIPLE 3-I/P NAND GATE	E0001	SN4343
A2MC21	1820-0054		IC QUAD 2-I/P NAND GATE	E0001	SN4342
A2MC22	1820-0069	9	IC DUAL 4-I/P NAND GATE	E0001	SN4344
A2MC23	1820-0069		IC DUAL 4-I/P NAND GATE	E0001	SN4344
A2MC24	1820-0068		IC TRIPLE 3-I/P NAND GATE	E0001	SN4343
A2MC25	1820-0054		IC QUAD 2-I/P NAND GATE	E0001	SN4342
A2MC26	1820-0054		IC QUAD 2-I/P NAND GATE	E0001	SN4342
A2MC27	1820-0054		IC QUAD 2-I/P NAND GATE	E0001	SN4342
A2MC31	1820-0069		IC DUAL 4-I/P NAND GATE	E0001	SN4344
A2MC32	1820-0328		IC QUAD 2-I/P NOR GATE	E0001	SN4467
A2MC33	1820-0070		IC 8-I/P NAND GATE	E0001	SN4345
A2MC34	1820-0054		IC QUAD 2-I/P NAND GATE	E0001	SN4342
A2MC35	1820-0054		IC QUAD 2-I/P NAND GATE	E0001	SN4342
A2MC36	1820-0054		IC QUAD 2-I/P NAND GATE	E0001	SN4342
A2MC37	1820-0328		IC QUAD 2-I/P NOR GATE	E0001	SN4467
A2MC41	1820-0054		IC QUAD 2-I/P NAND GATE	E0001	SN4342
A2MC42	1820-0328		IC QUAD 2-I/P NOR GATE	E0001	SN4467
A2MC43	1820-0054		IC QUAD 2-I/P NAND GATE	E0001	SN4342
A2MC44	1820-0068		IC TRIPLE 3-I/P NAND GATE	E0001	SN4343
A2MC45	1820-0068		IC TRIPLE 3-I/P NAND GATE	E0001	SN4343
A2MC46	1820-0328		IC QUAD 2-I/P NOR GATE	E0001	SN4467
A2MC47	1820-0068		IC TRIPLE 3-I/P NAND GATE	E0001	SN4343
A2MC51	1820-0077		IC DUAL D-TYPE FLIP-FLUP	E0001	SN4354
A2MC52	1820-0077		IC DUAL D-TYPE FLIP-FLUP	E0001	SN4354
A2MC53	1820-0077		IC DUAL D-TYPE FLIP-FLUP	E0001	SN4354
A2MC54	1820-0054		IC QUAD 2-I/P NAND GATE	E0001	SN4342
A2MC55	1820-0077		IC DUAL D-TYPE FLIP-FLUP	E0001	SN4354
A2MC56	1820-0054		IC QUAD 2-I/P NAND GATE	E0001	SN4342
A2MC57	1820-0054		IC QUAD 2-I/P NAND GATE	E0001	SN4342
A2MC63	1820-0068		IC TRIPLE 3-I/P NAND GATE	E0001	SN4343
A2MC64	1820-0054		IC QUAD 2-I/P NAND GATE	E0001	SN4342
A2MC65	1820-0054		IC QUAD 2-I/P NAND GATE	E0001	SN4342
A2Q1	1854-0019	67	XSTR SI NPN	13715	S-6516
A2Q2	1854-0019		XSTR SI NPN	13715	S-6516
A2Q3	1854-0053	4	XSTR SI NPN	04713	2N2218
A2Q4	1854-0019		XSTR SI NPN	13715	S-6516
A2Q5	1854-0019		XSTR SI NPN	13715	S-6516
A2R1	0757-0280		R FXD 1K OHM 1% 1/8W	75042	CEAT-0
A2R2	0757-0280		R FXD 1K OHM 1% 1/8W	75042	CEAT-0
A2R3	0757-0280		R FXD 1K OHM 1% 1/8W	75042	CEAT-0
A2R4	0757-0280		R FXD 1K OHM 1% 1/8W	75042	CEAT-0
A2R5	0757-0280		R FXD 1K OHM 1% 1/8W	75042	CEAT-0
A2R6	0757-0280		R FXD 1K OHM 1% 1/8W	75042	CEAT-0
A2R7	0757-0280		R FXD 1K OHM 1% 1/8W	75042	CEAT-0

Abbreviations are listed in the introduction to this section

Table 3-1 Replaceable Parts (continued)

Ref Desig	HP Part No	TQ	Description	Mfr	Mfr Part No
A2R8	0757-0280		R FXD 1K OHM 1% 1/8W	75042	CEAT-0
A2R9	0757-0280		R FXD 1K OHM 1% 1/8W	75042	CEAT-0
A2R10	0757-0280		R FXD 1K OHM 1% 1/8W	75042	CEAT-0
A2R11	0757-0280		R FXD 1K OHM 1% 1/8W	75042	CEAT-0
A2R12	0757-0416	17	R FXD 511 OHM 1% 1/8W	19701	MF4CT-0
A2R13	0757-0416		R FXD 511 OHM 1% 1/8W	19701	MF4CT-0
A2R14	0757-0408	2	R FXD 200 OHM 1% 1/8W	19701	MF4CT-0
A2R15	0757-0280		R FXD 1K OHM 1% 1/8W	75042	CEAT-0
A2R16	0757-0416		R FXD 511 OHM 1% 1/8W	19701	MF4CT-0
A2R17	0757-0416		R FXD 511 OHM 1% 1/8W	19701	MF4CT-0
A3			RANGE LOGIC ASSY		
	03720-30003	1	PC BD BLANK #NSR#	E0007	
	4040-0751	2	EXTRACTOR PC BD DRN	14493	5040-5114
	4040-0748		EXTRACTOR PC BD BLK	28480	5040-5111
	1480-0116		PIN GROOVE #TQ 2#	73957	GP24-063X250-12
A3C1	0190-0116		C FXD 6.8UF 10% 35WVDC	56289	150D685X9035B2-DYS
A3MC11	1820-0084	7	IC 4-WIDE 2-I/P AND/INV +XR GATE	E0001	SN4349
A3MC12	1820-0084		IC 4-WIDE 2-I/P AND/INV +XR GATE	E0001	SN4349
A3MC13	1820-0054		IC QUAD 2-I/P NAND GATE	E0001	SN4342
A3MC14	1820-0069		IC DUAL 4-I/P NAND GATE	E0001	SN4344
A3MC15	1820-0054		IC QUAD 2-I/P NAND GATE	E0001	SN4342
A3MC16	1820-0069		IC DUAL 4-I/P NAND GATE	E0001	SN4344
A3MC17	1820-0068		IC TRIPLE 3-I/P NAND GATE	E0001	SN4343
A3MC21	1820-0054		IC QUAD 2-I/P NAND GATE	E0001	SN4342
A3MC22	1820-0084		IC 4-WIDE 2-I/P AND/INV +XR GATE	E0001	SN4349
A3MC23	1820-0084		IC 4-WIDE 2-I/P AND/INV +XR GATE	E0001	SN4349
A3MC24	1820-0084		IC 4-WIDE 2-I/P AND/INV +XR GATE	E0001	SN4349
A3MC25	1820-0084		IC 4-WIDE 2-I/P AND/INV +XR GATE	E0001	SN4349
A3MC26	1820-0072	22	IC DUAL 2-WIDE 2-I/P AND/INV +XR GATE	E0001	SN4347
A3MC31	1820-0077		IC DUAL D-TYPE FLIP-FLOP	E0001	SN4354
A3MC32	1820-0070		IC 8-I/P NAND GATE	E0001	SN4345
A3MC33	1820-0054		IC QUAD 2-I/P NAND GATE	E0001	SN4342
A3MC34	1820-0069		IC DUAL 4-I/P NAND GATE	E0001	SN4344
A3MC35	1820-0085	2	IC DUAL 4-I/P XR GATE	E0001	SN4351
A3MC36	1820-0328		IC QUAD 2-I/P NOR GATE	E0001	SN4467
A3MC41	1820-0072		IC DUAL 2-WIDE 2-I/P AND/INV +XR GATE	E0001	SN4347
A3MC42	1820-0077		IC DUAL D-TYPE FLIP-FLOP	E0001	SN4354
A3MC43	1820-0077		IC DUAL D-TYPE FLIP-FLOP	E0001	SN4354
A3MC44	1820-0077		IC DUAL D-TYPE FLIP-FLOP	E0001	SN4354
A3MC45	1820-0077		IC DUAL D-TYPE FLIP-FLOP	E0001	SN4354
A3MC46	1820-0077		IC DUAL D-TYPE FLIP-FLOP	E0001	SN4354
A3MC51	1820-0328		IC QUAD 2-I/P NOR GATE	E0001	SN4467
A3MC52	1820-0072		IC DUAL 2-WIDE 2-I/P AND/INV +XR GATE	E0001	SN4347
A3MC53	1820-0072		IC DUAL 2-WIDE 2-I/P AND/INV +XR GATE	E0001	SN4347
A3MC54	1820-0328		IC QUAD 2-I/P NOR GATE	E0001	SN4467
A3MC55	1820-0085		IC DUAL 4-I/P XR GATE	E0001	SN4351
A3MC56	1820-0328		IC QUAD 2-I/P NOR GATE	E0001	SN4467
A3Q1	1854-0019		XSTR SI NPN	13715	S-6516
A3Q2	1854-0019		XSTR SI NPN	13715	S-6516
A3Q3	1854-0053		XSTR SI NPN	04713	2N2218
A3Q4	1854-0053		XSTR SI NPN	04713	2N2218
A3Q5	1854-0053		XSTR SI NPN	04713	2N2218

Abbreviations are listed in the introduction to this section

Table 3-1 Replaceable Parts (continued)

Ref Desig	HP Part No	TQ	Description	Mfr	Mfr Part No
A3R1	0757-0280		R FXD 1K OHM 1% 1/8W	75042	CEAT-0
A3R2	0757-0280		R FXD 1K OHM 1% 1/8W	75042	CEAT-0
A3R3	0757-0280		R FXD 1K OHM 1% 1/8W	75042	CEAT-0
A3R4	0757-0280		R FXD 1K OHM 1% 1/8W	75042	CEAT-0
A3R5	0757-0280		R FXD 1K OHM 1% 1/8W	75042	CEAT-0
A3R6	0757-0280		R FXD 1K OHM 1% 1/8W	75042	CEAT-0
A3R7	0757-0408		R FXD 200 OHM 1% 1/8W	19701	MF4CT-0
A3R8	0757-0280		R FXD 1K OHM 1% 1/8W	75042	CEAT-0
A3R9	0757-0280		R FXD 1K OHM 1% 1/8W	75042	CEAT-0
A3R10	0757-0280		R FXD 1K OHM 1% 1/8W	75042	CEAT-0
A3R11	0757-0280		R FXD 1K OHM 1% 1/8W	75042	CEAT-0
A3R12	0757-0280		R FXD 1K OHM 1% 1/8W	75042	CEAT-0
A3R13	0757-0416		R FXD 511 OHM 1% 1/8W	19701	MF4CT-0
A3R14	0757-0416		R FXD 511 OHM 1% 1/8W	19701	MF4CT-0
A3R15	0757-0416		R FXD 511 OHM 1% 1/8W	19701	MF4CT-0
A3R16			NOT ASSIGNED		
A3R17	0757-0280		R FXD 1K OHM 1% 1/8W	75042	CEAT-0
A3R18	0757-0280		R FXD 1K OHM 1% 1/8W	75042	CEAT-0
A3R19	0757-0280		R FXD 1K OHM 1% 1/8W	75042	CEAT-0
A3R20	0757-0280		R FXD 1K OHM 1% 1/8W	75042	CEAT-0
A3R21	0757-0280		R FXD 1K OHM 1% 1/8W	75042	CEAT-0
A3R22	0757-0416		R FXD 511 OHM 1% 1/8W	19701	MF4CT-0
A3R23	0757-0280		R FXD 1K OHM 1% 1/8W	75042	CEAT-0
A4			STORE 1 ASSY		
	03720-30004	1	PC BD BLANK #NSR#	E0007	
	4040-0752	2	EXTRACTOR PC BD YEL	14493	5040-5115
	4040-0748		EXTRACTOR PC BD BLK	28480	5040-5111
	1480-0116		PIN GROOVE #TQ 2#	73957	GP24-063X250-12
A4C1	0160-0156	1	C FXD 3900PF 10% 200WVDC	56289	192P39292-PTS
A4C2	0140-0200	4	C FXD 390PF 5% 300WVDC	72136	RDM15F391J3C
A4C3	0140-0197	3	C FXD 180PF 5% 300WVDC	72136	RDM15F181J3C
A4C4	0150-0093	3	C FXD 0.01UF +80-10% 100WVDC	91418	
A4C5	0140-0200		C FXD 390PF 5% 300WVDC	72136	RDM15F391J3C
A4C6	0140-0197		C FXD 180PF 5% 300WVDC	72136	RDM15F181J3C
A4C7	0150-0093		C FXD 0.01UF +80-10% 100WVDC	91418	
A4C8	0180-0229	2	C FXD 33UF 10% 10WVDC	56289	150D336X9010B2-DYS
A4C9	0180-1746	4	C FXD 15UF 10% 20WVDC	56289	150D156X9020B2-DYS
A4C10	0180-1746		C FXD 15UF 10% 20WVDC	56289	150D156X9020B2-DYS
A4CR1	1902-3036	3	DIO BKDN 3.16V 5% 400MW	04713	
A4MC12	1820-0075	14	IC DUAL JK FLIP-FLOP	E0001	SN4353
A4MC13	1820-0511	4	IC QUAD 2-I/P AND GATE	E0001	SN20572
A4MC14	1820-0054		IC QUAD 2-I/P NAND GATE	E0001	SN4342
A4MC15	1820-0075		IC DUAL JK FLIP-FLOP	E0001	SN4353
A4MC16	1820-0261	8	IC MONOSTABLE	E0001	SN74121N
A4MC17	1820-0075		IC DUAL JK FLIP-FLOP	E0001	SN4353
A4MC22	1820-0075		IC DUAL JK FLIP-FLOP	E0001	SN4353
A4MC23	1820-0068		IC TRIPLE 3-I/P NAND GATE	E0001	SN4343
A4MC24	1820-0054		IC QUAD 2-I/P NAND GATE	E0001	SN4342
A4MC25	1820-0075		IC DUAL JK FLIP-FLOP	E0001	SN4353
A4MC26	1820-0371	1	IC HS TRIPLE 3-I/P NAND GATE	E0001	SN4479
A4MC27	1820-0071	4	IC DUAL 4-I/P NAND BUFFER GATE	E0001	SN4346
A4MC32	1820-0261		IC MONOSTABLE	E0001	SN74121N
A4MC33	1820-0261		IC MONOSTABLE	E0001	SN74121N

Abbreviations are listed in the introduction to this section

Table 3-1 Replaceable Parts (continued)

Ref Desig	HP Part No	TQ	Description	Mfr	Mfr Part No
A4MC34	1820-0054		IC QUAD 2-I/P NAND GATE	E0001	SN4342
A4MC36	1820-0370	1	IC HS QUAD 2-I/P NAND GATE	E0001	SN4478
A4MC37	1820-0054		IC QUAD 2-I/P NAND GATE	E0001	SN4342
A4MC42	1820-0770	12	IC DUAL 100-BIT SHIFT REGISTER	12040	MM5006H
A4MC43	1820-0770		IC DUAL 100-BIT SHIFT REGISTER	12040	MM5006H
A4MC44	1820-0770		IC DUAL 100-BIT SHIFT REGISTER	12040	MM5006H
A4MC45	1820-0770		IC DUAL 100-BIT SHIFT REGISTER	12040	MM5006H
A4MC46	1820-0770		IC DUAL 100-BIT SHIFT REGISTER	12040	MM5006H
A4MC47	1820-0770		IC DUAL 100-BIT SHIFT REGISTER	12040	MM5006H
A4MC51	1820-0077		IC DUAL D-TYPE FLIP-FLOP	E0001	SN4354
A4MC52	1820-0328		IC QUAD 2-I/P NOR GATE	E0001	SN4467
A4MC53	1820-0328		IC QUAD 2-I/P NOR GATE	E0001	SN4467
A4MC54	1820-0328		IC QUAD 2-I/P NOR GATE	E0001	SN4467
A4MC55	1820-0328		IC QUAD 2-I/P NOR GATE	E0001	SN4467
A4MC56	1820-0328		IC QUAD 2-I/P NOR GATE	E0001	SN4467
A4MC57	1820-0328		IC QUAD 2-I/P NOR GATE	E0001	SN4467
A4MC61	1820-0328		IC QUAD 2-I/P NOR GATE	E0001	SN4467
A4MC62	1820-0072		IC DUAL 2-WIDE 2-I/P AND/INV +XR GATE	E0001	SN4347
A4MC63	1820-0072		IC DUAL 2-WIDE 2-I/P AND/INV +XR GATE	E0001	SN4347
A4MC64	1820-0072		IC DUAL 2-WIDE 2-I/P AND/INV +XR GATE	E0001	SN4347
A4MC65	1820-0072		IC DUAL 2-WIDE 2-I/P AND/INV +XR GATE	E0001	SN4347
A4MC66	1820-0072		IC DUAL 2-WIDE 2-I/P AND/INV +XR GATE	E0001	SN4347
A4MC67	1820-0072		IC DUAL 2-WIDE 2-I/P AND/INV +XR GATE	E0001	SN4347
A4Q1	1853-0036	59	XSTR SI PNP	04713	#2N3906# SPS-3612
A4Q2	1854-0045		XSTR SI NPN	07933	RT4299
A4Q2	1854-0045	3	XSTR SI NPN	07933	RT4299
A4Q3	1853-0036		XSTR SI PNP	04713	#2N3906# SPS-3612
A4Q4	1853-0036		XSTR SI PNP	04713	#2N3906# SPS-3612
A4Q5	1854-0045		XSTR SI NPN	07933	RT4299
A4Q6	1853-0036		XSTR SI PNP	04713	#2N3906# SPS-3612
A4R1	0757-0280		R FXD 1K OHM 1% 1/8W	75042	CEAT-0
A4R2	0698-3155	8	R FXD 4.64K OHM 1% 1/8W	19701	MF4CT-0
A4R3	0698-4636	2	R FXD 2.61K OHM 1% 1/4W	91637	MFF-1/8-32T-1
A4R4	0757-0284	4	R FXD 150 OHM 1% 1/8W	75042	CEAT-0
A4R5	0757-0280		R FXD 1K OHM 1% 1/8W	75042	CEAT-0
A4R6	0698-3155		R FXD 4.64K OHM 1% 1/8W	19701	MF4CT-0
A4R7	0698-4636		R FXD 2.61K OHM 1% 1/4W	91637	MFF-1/8-32T-1
A4R8	0757-0284		R FXD 150 OHM 1% 1/8W	75042	CEAT-0
A4R8	0757-0284		R FXD 150 OHM 1% 1/8W	75042	CEAT-0
A4R9	0757-0280		R FXD 1K OHM 1% 1/8W	75042	CEAT-0
A4R9	0757-0280		R FXD 1K OHM 1% 1/8W	75042	CEAT-0
A4R10	0757-0280		R FXD 1K OHM 1% 1/8W	75042	CEAT-0
A4R11	0757-0280		R FXD 1K OHM 1% 1/8W	75042	CEAT-0
A4R12	0698-5490		R FXD 2K OHM 1% 1/8W	91637	CMF-1/10-32T-2
A4R13	0757-0280		R FXD 1K OHM 1% 1/8W	75042	CEAT-0
A4R14	0757-0280		R FXD 1K OHM 1% 1/8W	75042	CEAT-0
A4R15	0757-0280		R FXD 1K OHM 1% 1/8W	75042	CEAT-0
A4R16	0698-5490		R FXD 2K OHM 1% 1/8W	91637	CMF-1/10-32T-2
A4R17	0698-5490		R FXD 2K OHM 1% 1/8W	91637	CMF-1/10-32T-2
A5			STORE 2 ASSY		
	03720-30005	1	PC BD BLANK #NSR#	E0007	
	4040-0753	2	EXTRACTOR PC BD GRN	14493	5040-5116
	4040-0748		EXTRACTOR PC BD BLK	28480	5040-5111

Abbreviations are listed in the introduction to this section

Table 3-1 Replaceable Parts (continued)

Ref Desig	HP Part No	TQ	Description	Mfr	Mfr Part No
	1480-0116		PIN GROOVE #TQ 2#	73957	GP24-063X250-12
A5C1	0180-0229		C FXD 33UF 10% 10WVDC	56289	150D336X9010B2-DYS
A5C2	0180-1746		C FXD 15UF 10% 20WVDC	56289	150D156X9020B2-UYS
A5CR1	1902-3036		DIO BKDN 3.16V 5% 400MW	04713	
A5MC11	1820-0305	3	IC 4-BIT ADDER	E0001	SN4465
A5MC12	1820-0071		IC DUAL 4-I/P NAND BUFFER GATE	E0001	SN4346
A5MC13	1820-0305		IC 4-BIT ADDER	E0001	SN4465
A5MC14	1820-0054		IC QUAD 2-I/P NAND GATE	E0001	SN4342
A5MC15	1820-0305		IC 4-BIT ADDER	E0001	SN4465
A5MC16	1820-0071		IC DUAL 4-I/P NAND BUFFER GATE	E0001	SN4346
A5MC21	1820-0282	6	IC QUAD 2-I/P EXCLUSIVE OR GATE	E0001	SN13603
A5MC22	1820-0282		IC QUAD 2-I/P EXCLUSIVE OR GATE	E0001	SN13603
A5MC23	1820-0282		IC QUAD 2-I/P EXCLUSIVE OR GATE	E0001	SN13603
A5MC24	1820-0282		IC QUAD 2-I/P EXCLUSIVE OR GATE	E0001	SN13603
A5MC25	1820-0282		IC QUAD 2-I/P EXCLUSIVE OR GATE	E0001	SN13603
A5MC26	1820-0282		IC QUAD 2-I/P EXCLUSIVE OR GATE	E0001	SN13603
A5MC31	1820-0072		IC DUAL 2-WIDE 2-I/P AND/INV +XR GATE	E0001	SN4347
A5MC32	1820-0072		IC DUAL 2-WIDE 2-I/P AND/INV +XR GATE	E0001	SN4347
A5MC33	1820-0072		IC DUAL 2-WIDE 2-I/P AND/INV +XR GATE	E0001	SN4347
A5MC34	1820-0072		IC DUAL 2-WIDE 2-I/P AND/INV +XR GATE	E0001	SN4347
A5MC35	1820-0072		IC DUAL 2-WIDE 2-I/P AND/INV +XR GATE	E0001	SN4347
A5MC36	1820-0072		IC DUAL 2-WIDE 2-I/P AND/INV +XR GATE	E0001	SN4347
A5MC41	1820-0770		IC DUAL 100-BIT SHIFT REGISTER	12040	MM5006H
A5MC42	1820-0770		IC DUAL 100-BIT SHIFT REGISTER	12040	MM5006H
A5MC43	1820-0770		IC DUAL 100-BIT SHIFT REGISTER	12040	MM5006H
A5MC44	1820-0770		IC DUAL 100-BIT SHIFT REGISTER	12040	MM5006H
A5MC45	1820-0770		IC DUAL 100-BIT SHIFT REGISTER	12040	MM5006H
A5MC46	1820-0770		IC DUAL 100-BIT SHIFT REGISTER	12040	MM5006H
A5MC51	1820-0328		IC QUAD 2-I/P NOR GATE	E0001	SN4467
A5MC52	1820-0328		IC QUAD 2-I/P NOR GATE	E0001	SN4467
A5MC53	1820-0328		IC QUAD 2-I/P NOR GATE	E0001	SN4467
A5MC54	1820-0328		IC QUAD 2-I/P NOR GATE	E0001	SN4467
A5MC55	1820-0328		IC QUAD 2-I/P NOR GATE	E0001	SN4467
A5MC56	1820-0328		IC QUAD 2-I/P NOR GATE	E0001	SN4467
A5MC61	1820-0072		IC DUAL 2-WIDE 2-I/P AND/INV +XR GATE	E0001	SN4347
A5MC62	1820-0072		IC DUAL 2-WIDE 2-I/P AND/INV +XR GATE	E0001	SN4347
A5MC63	1820-0072		IC DUAL 2-WIDE 2-I/P AND/INV +XR GATE	E0001	SN4347
A5MC64	1820-0072		IC DUAL 2-WIDE 2-I/P AND/INV +XR GATE	E0001	SN4347
A5MC65	1820-0072		IC DUAL 2-WIDE 2-I/P AND/INV +XR GATE	E0001	SN4347
A5MC66	1820-0072		IC DUAL 2-WIDE 2-I/P AND/INV +XR GATE	E0001	SN4347
A5R1	0698-5490		R FXD 2K OHM 1% 1/8W	91637	CMF-1/10-32T-2
A6			BUFFER ASSY		
	03720-30006	1	PC BD BLANK #NSR#	E0007	
	4040-0754	2	EXTRACTOR PC BD BLU	14493	5040-5117
	4040-0748		EXTRACTOR PC BD BLK	28480	5040-5111
	1480-0116		PIN GROOVE #TQ 2#	73957	GP24-063X250-12
A6C1	0180-0116		C FXD 6.8UF 10% 35WVDC	56289	150D685X9035B2-DYS
A6C2	0180-0116		C FXD 6.8UF 10% 35WVDC	56289	150D685X9035B2-DYS
A6CR1	1902-3036		DIO BKDN 3.16V 5% 400MW	04713	
A6MC14	1820-0054		IC QUAD 2-I/P NAND GATE	E0001	SN4342

Abbreviations are listed in the introduction to this section

Table 3-1 Replaceable Parts (continued)

Ref Desig	HP Part No	TQ	Description	Mfr	Mfr Part No
A6MC21	1820-0107	5	IC QUAD INTERFACE BUFFER GATE	14493	8902-5080
A6MC22	1820-0054		IC QUAD 2-I/P NAND GATE	E0001	SN4342
A6MC23	1820-0054		IC QUAD 2-I/P NAND GATE	E0001	SN4342
A6MC24	1820-0077		IC DUAL D-TYPE FLIP-FLOP	E0001	SN4354
A6MC25	1820-0107		IC QUAD INTERFACE BUFFER GATE	14493	8902-5080
A6MC26	1820-0054		IC QUAD 2-I/P NAND GATE	E0001	SN4342
A6MC31	1820-0107		IC QUAD INTERFACE BUFFER GATE	14493	8902-5080
A6MC32	1820-0054		IC QUAD 2-I/P NAND GATE	E0001	SN4342
A6MC33	1820-0107		IC QUAD INTERFACE BUFFER GATE	14493	8902-5080
A6MC34	1820-0054		IC QUAD 2-I/P NAND GATE	E0001	SN4342
A6MC35	1820-0107		IC QUAD INTERFACE BUFFER GATE	14493	8902-5080
A6MC36	1820-0068		IC TRIPLE 3-I/P NAND GATE	E0001	SN4343
A6MC46	1820-0328		IC QUAD 2-I/P NUR GATE	E0001	SN4467
A6R1	0698-5490		R FXD 2K OHM 1% 1/8W	91637	CMF-1/10-32T-2
A6R2	0757-0280		R FXD 1K OHM 1% 1/8W	75042	CEAT-0
A6R3	0698-5490		R FXD 2K OHM 1% 1/8W	91637	CMF-1/10-32T-2
A6R4	0757-0280		R FXD 1K OHM 1% 1/8W	75042	CEAT-0
A6R5	0698-5490		R FXD 2K OHM 1% 1/8W	91637	CMF-1/10-32T-2
A6R6	0757-0280		R FXD 1K OHM 1% 1/8W	75042	CEAT-0
A6R7	0698-5490		R FXD 2K OHM 1% 1/8W	91637	CMF-1/10-32T-2
A6R8	0757-0280		R FXD 1K OHM 1% 1/8W	75042	CEAT-0
A6R9	0698-5490		R FXD 2K OHM 1% 1/8W	91637	CMF-1/10-32T-2
A6R10	0757-0280		R FXD 1K OHM 1% 1/8W	75042	CEAT-0
A6R11	0698-5490		R FXD 2K OHM 1% 1/8W	91637	CMF-1/10-32T-2
A6R12	0757-0280		R FXD 1K OHM 1% 1/8W	75042	CEAT-0
A6R13	0698-5490		R FXD 2K OHM 1% 1/8W	91637	CMF-1/10-32T-2
A6R14	0757-0280		R FXD 1K OHM 1% 1/8W	75042	CEAT-0
A6R15	0698-5490		R FXD 2K OHM 1% 1/8W	91637	CMF-1/10-32T-2
A6R16	0757-0280		R FXD 1K OHM 1% 1/8W	75042	CEAT-0
A6R17	0698-5490		R FXD 2K OHM 1% 1/8W	91637	CMF-1/10-32T-2
A6R18	0757-0280		R FXD 1K OHM 1% 1/8W	75042	CEAT-0
A6R19	0698-5490		R FXD 2K OHM 1% 1/8W	91637	CMF-1/10-32T-2
A6R20	0757-0280		R FXD 1K OHM 1% 1/8W	75042	CEAT-0
A6R21	0698-5490		R FXD 2K OHM 1% 1/8W	91637	CMF-1/10-32T-2
A6R22	0757-0280		R FXD 1K OHM 1% 1/8W	75042	CEAT-0
A6R23	0698-5490		R FXD 2K OHM 1% 1/8W	91637	CMF-1/10-32T-2
A6R24	0757-0280		R FXD 1K OHM 1% 1/8W	75042	CEAT-0
A6R25	0698-5490		R FXD 2K OHM 1% 1/8W	91637	CMF-1/10-32T-2
A6R26	0757-0280		R FXD 1K OHM 1% 1/8W	75042	CEAT-0
A6R27	0698-5490		R FXD 2K OHM 1% 1/8W	91637	CMF-1/10-32T-2
A6R28	0757-0280		R FXD 1K OHM 1% 1/8W	75042	CEAT-0
A6R29	0757-0280		R FXD 1K OHM 1% 1/8W	75042	CEAT-0
A6R30	0757-0280		R FXD 1K OHM 1% 1/8W	75042	CEAT-0
A6R31	0698-5490		R FXD 2K OHM 1% 1/8W	91637	CMF-1/10-32T-2
A6R32	0757-0280		R FXD 1K OHM 1% 1/8W	75042	CEAT-0
A6R33	0757-0280		R FXD 1K OHM 1% 1/8W	75042	CEAT-0
A6R34	0757-0280		R FXD 1K OHM 1% 1/8W	75042	CEAT-0
A7			SWITCH CARD ASSY		
	03720-30007	1	PC BD BLANK #NSR#	E0007	
	4040-0755	1	EXTRACTOR PC BD VIO	14493	5040-5118
	4040-0749	11	EXTRACTOR PC BD BRN	14493	5040-5112
	1480-0116		PIN GROOVE #TQ 2#	73957	GP24-063X250-12
A7C1	0160-2204	18	C FXD 100PF 5% 300WVDC	72136	RDM15F101J3C

Abbreviations are listed in the introduction to this section

Table 3-1 Replaceable Parts (continued)

Ref Desig	HP Part No	TQ	Description	Mfr	Mfr Part No
A7C2	0160-0333	24	C FXD 15PF 0.5PF 300WVDC	72136	RDM15C150D3C
A7C3	0160-0333		C FXD 15PF 0.5PF 300WVDC	72136	RDM15C150D3C
A7C11	0160-2204		C FXD 100PF 5% 300WVDC	72136	RDM15F101J3C
A7C12	0160-0333		C FXD 15PF 0.5PF 300WVDC	72136	RDM15C150D3C
A7C13	0160-0333		C FXD 15PF 0.5PF 300WVDC	72136	RDM15C150D3C
A7C21	0160-2204		C FXD 100PF 5% 300WVDC	72136	RDM15F101J3C
A7C22	0160-0333		C FXD 15PF 0.5PF 300WVDC	72136	RDM15C150D3C
A7C23	0160-0333		C FXD 15PF 0.5PF 300WVDC	72136	RDM15C150D3C
A7C31	0160-2204		C FXD 100PF 5% 300WVDC	72136	RDM15F101J3C
A7C32	0160-0333		C FXD 15PF 0.5PF 300WVDC	72136	RDM15C150D3C
A7C33	0160-0333		C FXD 15PF 0.5PF 300WVDC	72136	RDM15C150D3C
A7C41	0160-2204		C FXD 100PF 5% 300WVDC	72136	RDM15F101J3C
A7C42	0160-0333		C FXD 15PF 0.5PF 300WVDC	72136	RDM15C150D3C
A7C43	0160-0333		C FXD 15PF 0.5PF 300WVDC	72136	RDM15C150D3C
A7C51	0160-2204		C FXD 100PF 5% 300WVDC	72136	RDM15F101J3C
A7C52	0160-0333		C FXD 15PF 0.5PF 300WVDC	72136	RDM15C150D3C
A7C53	0160-0333		C FXD 15PF 0.5PF 300WVDC	72136	RDM15C150D3C
A7C61	0160-2204		C FXD 100PF 5% 300WVDC	72136	RDM15F101J3C
A7C62	0160-0333		C FXD 15PF 0.5PF 300WVDC	72136	RDM15C150D3C
A7C63	0160-0333		C FXD 15PF 0.5PF 300WVDC	72136	RDM15C150D3C
A7C71	0160-2204		C FXD 100PF 5% 300WVDC	72136	RDM15F101J3C
A7C72	0160-0333		C FXD 15PF 0.5PF 300WVDC	72136	RDM15C150D3C
A7C73	0160-0333		C FXD 15PF 0.5PF 300WVDC	72136	RDM15C150D3C
A7C81	0160-2204		C FXD 100PF 5% 300WVDC	72136	RDM15F101J3C
A7C82	0160-0333		C FXD 15PF 0.5PF 300WVDC	72136	RDM15C150D3C
A7C83	0160-0333		C FXD 15PF 0.5PF 300WVDC	72136	RDM15C150D3C
A7C91	0160-2204		C FXD 100PF 5% 300WVDC	72136	RDM15F101J3C
A7C92	0160-0333		C FXD 15PF 0.5PF 300WVDC	72136	RDM15C150D3C
A7C93	0160-0333		C FXD 15PF 0.5PF 300WVDC	72136	RDM15C150D3C
A7C101	0160-2204		C FXD 100PF 5% 300WVDC	72136	RDM15F101J3C
A7C102	0160-0333		C FXD 15PF 0.5PF 300WVDC	72136	RDM15C150D3C
A7C103	0160-0333		C FXD 15PF 0.5PF 300WVDC	72136	RDM15C150D3C
A7C111	0160-2204		C FXD 100PF 5% 300WVDC	72136	RDM15F101J3C
A7C112	0160-0333		C FXD 15PF 0.5PF 300WVDC	72136	RDM15C150D3C
A7C113	0160-0333		C FXD 15PF 0.5PF 300WVDC	72136	RDM15C150D3C
A7C121	0180-0116		C FXD 6.8UF 10% 35WVDC	56289	150D685X9035B2-DYS
A7C122	0180-0116		C FXD 6.8UF 10% 35WVDC	56289	150D685X9035B2-DYS
A7CR1	1901-0040		DIO SI	12065	SG5050
A7CR2	1901-0040		DIO SI	12065	SG5050
A7CR11	1901-0040		DIO SI	12065	SG5050
A7CR12	1901-0040		DIO SI	12065	SG5050
A7CR21	1901-0040		DIO SI	12065	SG5050
A7CR22	1901-0040		DIO SI	12065	SG5050
A7CR31	1901-0040		DIO SI	12065	SG5050
A7CR32	1901-0040		DIO SI	12065	SG5050
A7CR41	1901-0040		DIO SI	12065	SG5050
A7CR42	1901-0040		DIO SI	12065	SG5050
A7CR51	1901-0040		DIO SI	12065	SG5050
A7CR52	1901-0040		DIO SI	12065	SG5050
A7CR61	1901-0040		DIO SI	12065	SG5050
A7CR62	1901-0040		DIO SI	12065	SG5050
A7CR71	1901-0040		DIO SI	12065	SG5050
A7CR72	1901-0040		DIO SI	12065	SG5050
A7CR81	1901-0040		DIO SI	12065	SG5050
A7CR82	1901-0040		DIO SI	12065	SG5050

Abbreviations are listed in the introduction to this section

Table 3-1 Replaceable Parts (continued)

Ref Desig	HP Part No	TQ	Description	Mfr	Mfr Part No
A7CR91	1901-0040		DIO SI	12065	SG5050
A7CR92	1901-0040		DIO SI	12065	SG5050
A7CR101	1901-0040		DIO SI	12065	SG5050
A7CR102	1901-0040		DIO SI	12065	SG5050
A7CR111	1901-0040		DIO SI	12065	SG5050
A7CR112	1901-0040		DIO SI	12065	SG5050
A7Q1	1854-0019		XSTR SI NPN	13715	S-6516
A7Q2	1853-0036		XSTR SI PNP	04713	#2N3906# SPS-3612
A7Q3	1854-0215	16	XSTR SI NPN	04713	SPS3611
A7Q4	1855-0020	67	XSTR FET N-CHANNEL	21845	F1151
A7Q5	1855-0020		XSTR FET N-CHANNEL	21845	F1151
A7Q11	1854-0019		XSTR SI NPN	13715	S-6516
A7Q12	1853-0036		XSTR SI PNP	04713	#2N3906# SPS-3612
A7Q13	1854-0215		XSTR SI NPN	04713	SPS3611
A7Q14	1855-0020		XSTR FET N-CHANNEL	21845	F1151
A7Q15	1855-0020		XSTR FET N-CHANNEL	21845	F1151
A7Q21	1854-0019		XSTR SI NPN	13715	S-6516
A7Q22	1853-0036		XSTR SI PNP	04713	#2N3906# SPS-3612
A7Q23	1854-0215		XSTR SI NPN	04713	SPS3611
A7Q24	1855-0020		XSTR FET N-CHANNEL	21845	F1151
A7Q25	1855-0020		XSTR FET N-CHANNEL	21845	F1151
A7Q31	1854-0019		XSTR SI NPN	13715	S-6516
A7Q32	1853-0036		XSTR SI PNP	04713	#2N3906# SPS-3612
A7Q33	1854-0215		XSTR SI NPN	04713	SPS3611
A7Q34	1855-0020		XSTR FET N-CHANNEL	21845	F1151
A7Q35	1855-0020		XSTR FET N-CHANNEL	21845	F1151
A7Q41	1854-0019		XSTR SI NPN	13715	S-6516
A7Q42	1853-0036		XSTR SI PNP	04713	#2N3906# SPS-3612
A7Q43	1854-0215		XSTR SI NPN	04713	SPS3611
A7Q44	1855-0020		XSTR FET N-CHANNEL	21845	F1151
A7Q45	1855-0020		XSTR FET N-CHANNEL	21845	F1151
A7Q51	1854-0019		XSTR SI NPN	13715	S-6516
A7Q52	1853-0036		XSTR SI PNP	04713	#2N3906# SPS-3612
A7Q53	1854-0215		XSTR SI NPN	04713	SPS3611
A7Q54	1855-0020		XSTR FET N-CHANNEL	21845	F1151
A7Q55	1855-0020		XSTR FET N-CHANNEL	21845	F1151
A7Q61	1854-0019		XSTR SI NPN	13715	S-6516
A7Q62	1853-0036		XSTR SI PNP	04713	#2N3906# SPS-3612
A7Q63	1854-0215		XSTR SI NPN	04713	SPS3611
A7Q64	1855-0020		XSTR FET N-CHANNEL	21845	F1151
A7Q65	1855-0020		XSTR FET N-CHANNEL	21845	F1151
A7Q71	1854-0019		XSTR SI NPN	13715	S-6516
A7Q72	1853-0036		XSTR SI PNP	04713	#2N3906# SPS-3612
A7Q73	1854-0215		XSTR SI NPN	04713	SPS3611
A7Q74	1855-0020		XSTR FET N-CHANNEL	21845	F1151
A7Q75	1855-0020		XSTR FET N-CHANNEL	21845	F1151
A7Q81	1854-0019		XSTR SI NPN	13715	S-6516
A7Q82	1853-0036		XSTR SI PNP	04713	#2N3906# SPS-3612
A7Q83	1854-0215		XSTR SI NPN	04713	SPS3611
A7Q84	1855-0020		XSTR FET N-CHANNEL	21845	F1151
A7Q85	1855-0020		XSTR FET N-CHANNEL	21845	F1151
A7Q91	1854-0019		XSTR SI NPN	13715	S-6516
A7Q92	1853-0036		XSTR SI PNP	04713	#2N3906# SPS-3612
A7Q93	1854-0215		XSTR SI NPN	04713	SPS3611
A7Q94	1855-0020		XSTR FET N-CHANNEL	21845	F1151

Abbreviations are listed in the introduction to this section

Table 3-1 Replaceable Parts (continued)

Ref Desig	HP Part No	TQ	Description	Mfr	Mfr Part No
A7Q95	1855-0020		XSTR FET N-CHANNEL	21845	F1151
A7Q101	1854-0019		XSTR SI NPN	13715	S-6516
A7Q102	1853-0036		XSTR SI PNP	04713	#2N3906# SPS-3612
A7Q103	1854-0215		XSTR SI NPN	04713	SPS3611
A7Q104	1855-0020		XSTR FET N-CHANNEL	21845	F1151
A7Q105	1855-0020		XSTR FET N-CHANNEL	21845	F1151
A7Q111	1854-0019		XSTR SI NPN	13715	S-6516
A7Q112	1853-0036		XSTR SI PNP	04713	#2N3906# SPS-3612
A7Q113	1854-0215		XSTR SI NPN	04713	SPS3611
A7Q114	1855-0020		XSTR FET N-CHANNEL	21845	F1151
A7Q115	1855-0020		XSTR FET N-CHANNEL	21845	F1151
A7R1	0698-5490		R FXD 2K OHM 1% 1/8W	91637	CMF-1/10-32T-2
A7R2	0698-5490		R FXD 2K OHM 1% 1/8W	91637	CMF-1/10-32T-2
A7R3	0698-3446	55	R FXD 383 OHM 1% 1/8W	19701	MF4CT-0
A7R4	0698-3153	42	R FXD 3.83K OHM 1% 1/8W	19701	MF4CT-0
A7R5	0757-0750	51	R FXD 6.81K OHM 1% 1/4W	19701	MF52CT-0
A7R6	0757-0449	13	R FXD 20K OHM 1% 1/8W	19701	MF4CT-0
A7R7	0757-0750		R FXD 6.81K OHM 1% 1/4W	19701	MF52CT-0
A7R8	0757-0465	91	R FXD 100K OHM 1% 1/8W	19701	MF4CT-0
A7R9	0757-0482	18	R FXD 511K OHM 1% 1/8W	19701	MF5C T-0
A7R11	0698-5490		R FXD 2K OHM 1% 1/8W	91637	CMF-1/10-32T-2
A7R12	0698-5490		R FXD 2K OHM 1% 1/8W	91637	CMF-1/10-32T-2
A7R13	0698-3446		R FXD 383 OHM 1% 1/8W	19701	MF4CT-0
A7R14	0698-3153		R FXD 3.83K OHM 1% 1/8W	19701	MF4CT-0
A7R15	0757-0750		R FXD 6.81K OHM 1% 1/4W	19701	MF52CT-0
A7R16	0757-0449		R FXD 20K OHM 1% 1/8W	19701	MF4CT-0
A7R17	0757-0750		R FXD 6.81K OHM 1% 1/4W	19701	MF52CT-0
A7R18	0757-0465		R FXD 100K OHM 1% 1/8W	19701	MF4CT-0
A7R19	0757-0482		R FXD 511K OHM 1% 1/8W	19701	MF5C T-0
A7R21	0698-5490		R FXD 2K OHM 1% 1/8W	91637	CMF-1/10-32T-2
A7R22	0698-5490		R FXD 2K OHM 1% 1/8W	91637	CMF-1/10-32T-2
A7R23	0698-3446		R FXD 383 OHM 1% 1/8W	19701	MF4CT-0
A7R24	0698-3153		R FXD 3.83K OHM 1% 1/8W	19701	MF4CT-0
A7R25	0757-0750		R FXD 6.81K OHM 1% 1/4W	19701	MF52CT-0
A7R26	0757-0449		R FXD 20K OHM 1% 1/8W	19701	MF4CT-0
A7R27	0757-0750		R FXD 6.81K OHM 1% 1/4W	19701	MF52CT-0
A7R28	0757-0465		R FXD 100K OHM 1% 1/8W	19701	MF4CT-0
A7R29	0757-0482		R FXD 511K OHM 1% 1/8W	19701	MF5C T-0
A7R31	0698-5490		R FXD 2K OHM 1% 1/8W	91637	CMF-1/10-32T-2
A7R32	0698-5490		R FXD 2K OHM 1% 1/8W	91637	CMF-1/10-32T-2
A7R33	0698-3446		R FXD 383 OHM 1% 1/8W	19701	MF4CT-0
A7R34	0698-3153		R FXD 3.83K OHM 1% 1/8W	19701	MF4CT-0
A7R35	0757-0750		R FXD 6.81K OHM 1% 1/4W	19701	MF52CT-0
A7R36	0757-0449		R FXD 20K OHM 1% 1/8W	19701	MF4CT-0
A7R37	0757-0750		R FXD 6.81K OHM 1% 1/4W	19701	MF52CT-0
A7R38	0757-0465		R FXD 100K OHM 1% 1/8W	19701	MF4CT-0
A7R39	0757-0482		R FXD 511K OHM 1% 1/8W	19701	MF5C T-0
A7R41	0698-5490		R FXD 2K OHM 1% 1/8W	91637	CMF-1/10-32T-2
A7R42	0698-5490		R FXD 2K OHM 1% 1/8W	91637	CMF-1/10-32T-2
A7R43	0698-3446		R FXD 383 OHM 1% 1/8W	19701	MF4CT-0
A7R44	0698-3153		R FXD 3.83K OHM 1% 1/8W	19701	MF4CT-0
A7R45	0757-0750		R FXD 6.81K OHM 1% 1/4W	19701	MF52CT-0
A7R46	0757-0449		R FXD 20K OHM 1% 1/8W	19701	MF4CT-0
A7R47	0757-0750		R FXD 6.81K OHM 1% 1/4W	19701	MF52CT-0
A7R48	0757-0465		R FXD 100K OHM 1% 1/8W	19701	MF4CT-0

Abbreviations are listed in the introduction to this section

Table 3-1 Replaceable Parts (continued)

Ref Desig	HP Part No	TQ	Description	Mfr	Mfr Part No
A7R49	0757-0482		R FXD 511K OHM 1% 1/8W	19701	MF5C T-0
A7R51	0698-5490		R FXD 2K OHM 1% 1/8W	91637	CMF-1/10-32T-2
A7R52	0698-5490		R FXD 2K OHM 1% 1/8W	91637	CMF-1/10-32T-2
A7R53	0698-3446		R FXD 383 OHM 1% 1/8W	19701	MF4CT-0
A7R54	0698-3153		R FXD 3.83K OHM 1% 1/8W	19701	MF4CT-0
A7R55	0757-0750		R FXD 6.81K OHM 1% 1/4W	19701	MF52CT-0
A7R56	0757-0449		R FXD 20K OHM 1% 1/8W	19701	MF4CT-0
A7R57	0757-0750		R FXD 6.81K OHM 1% 1/4W	19701	MF52CT-0
A7R58	0757-0465		R FXD 100K OHM 1% 1/8W	19701	MF4CT-0
A7R59	0757-0482		R FXD 511K OHM 1% 1/8W	19701	MF5C T-0
A7R61	0698-5490		R FXD 2K OHM 1% 1/8W	91637	CMF-1/10-32T-2
A7R62	0698-5490		R FXD 2K OHM 1% 1/8W	91637	CMF-1/10-32T-2
A7R63	0698-3446		R FXD 383 OHM 1% 1/8W	19701	MF4CT-0
A7R64	0698-3153		R FXD 3.83K OHM 1% 1/8W	19701	MF4CT-0
A7R65	0757-0750		R FXD 6.81K OHM 1% 1/4W	19701	MF52CT-0
A7R66	0757-0449		R FXD 20K OHM 1% 1/8W	19701	MF4CT-0
A7R67	0757-0750		R FXD 6.81K OHM 1% 1/4W	19701	MF52CT-0
A7R68	0757-0465		R FXD 100K OHM 1% 1/8W	19701	MF4CT-0
A7R69	0757-0482		R FXD 511K OHM 1% 1/8W	19701	MF5C T-0
A7R71	0698-5490		R FXD 2K OHM 1% 1/8W	91637	CMF-1/10-32T-2
A7R72	0698-5490		R FXD 2K OHM 1% 1/8W	91637	CMF-1/10-32T-2
A7R73	0698-3446		R FXD 383 OHM 1% 1/8W	19701	MF4CT-0
A7R74	0698-3153		R FXD 3.83K OHM 1% 1/8W	19701	MF4CT-0
A7R75	0757-0750		R FXD 6.81K OHM 1% 1/4W	19701	MF52CT-0
A7R76	0757-0449		R FXD 20K OHM 1% 1/8W	19701	MF4CT-0
A7R77	0757-0750		R FXD 6.81K OHM 1% 1/4W	19701	MF52CT-0
A7R78	0757-0465		R FXD 100K OHM 1% 1/8W	19701	MF4CT-0
A7R79	0757-0482		R FXD 511K OHM 1% 1/8W	19701	MF5C T-0
A7R81	0698-5490		R FXD 2K OHM 1% 1/8W	91637	CMF-1/10-32T-2
A7R82	0698-5490		R FXD 2K OHM 1% 1/8W	91637	CMF-1/10-32T-2
A7R83	0698-3446		R FXD 383 OHM 1% 1/8W	19701	MF4CT-0
A7R84	0698-3153		R FXD 3.83K OHM 1% 1/8W	19701	MF4CT-0
A7R85	0757-0750		R FXD 6.81K OHM 1% 1/4W	19701	MF52CT-0
A7R86	0757-0449		R FXD 20K OHM 1% 1/8W	19701	MF4CT-0
A7R87	0757-0750		R FXD 6.81K OHM 1% 1/4W	19701	MF52CT-0
A7R88	0757-0465		R FXD 100K OHM 1% 1/8W	19701	MF4CT-0
A7R89	0757-0482		R FXD 511K OHM 1% 1/8W	19701	MF5C T-0
A7R91	0698-5490		R FXD 2K OHM 1% 1/8W	91637	CMF-1/10-32T-2
A7R92	0698-5490		R FXD 2K OHM 1% 1/8W	91637	CMF-1/10-32T-2
A7R93	0698-3446		R FXD 383 OHM 1% 1/8W	19701	MF4CT-0
A7R94	0698-3153		R FXD 3.83K OHM 1% 1/8W	19701	MF4CT-0
A7R95	0757-0750		R FXD 6.81K OHM 1% 1/4W	19701	MF52CT-0
A7R96	0757-0449		R FXD 20K OHM 1% 1/8W	19701	MF4CT-0
A7R97	0757-0750		R FXD 6.81K OHM 1% 1/4W	19701	MF52CT-0
A7R98	0757-0465		R FXD 100K OHM 1% 1/8W	19701	MF4CT-0
A7R99	0757-0482		R FXD 511K OHM 1% 1/8W	19701	MF5C T-0
A7R101	0698-5490		R FXD 2K OHM 1% 1/8W	91637	CMF-1/10-32T-2
A7R102	0698-5490		R FXD 2K OHM 1% 1/8W	91637	CMF-1/10-32T-2
A7R103	0698-3446		R FXD 383 OHM 1% 1/8W	19701	MF4CT-0
A7R104	0698-3153		R FXD 3.83K OHM 1% 1/8W	19701	MF4CT-0
A7R105	0757-0750		R FXD 6.81K OHM 1% 1/4W	19701	MF52CT-0
A7R106	0757-0449		R FXD 20K OHM 1% 1/8W	19701	MF4CT-0
A7R107	0757-0750		R FXD 6.81K OHM 1% 1/4W	19701	MF52CT-0
A7R108	0757-0465		R FXD 100K OHM 1% 1/8W	19701	MF4CT-0
A7R109	0757-0482		R FXD 511K OHM 1% 1/8W	19701	MF5C T-0

Abbreviations are listed in the introduction to this section

Table 3-1 Replaceable Parts (continued)

Ref Desig	HP Part No	TQ	Description	Mfr	Mfr Part No
A7R111	0698-5490		R FXD 2K OHM 1% 1/8W	91637	CMF-1/10-32T-2
A7R112	0698-5490		R FXD 2K OHM 1% 1/8W	91637	CMF-1/10-32T-2
A7R113	0698-3446		R FXD 383 OHM 1% 1/8W	19701	MF4CT-0
A7R114	0698-3153		R FXD 3.83K OHM 1% 1/8W	19701	MF4CT-0
A7R115	0757-0750		R FXD 6.81K OHM 1% 1/4W	19701	MF52CT-0
A7R116	0757-0449		R FXD 20K OHM 1% 1/8W	19701	MF4CT-0
A7R117	0757-0750		R FXD 6.81K OHM 1% 1/4W	19701	MF52CT-0
A7R118	0757-0465		R FXD 100K OHM 1% 1/8W	19701	MF4CT-0
A7R119	0757-0482		R FXD 511K OHM 1% 1/8W	19701	MF5C T-0
A8			HYBRID MULTIPLIER ASSY		
	03720-30008	1	PC BD BLANK #NSR#	E0007	
	4040-0747	1	EXTRACTOR PC BD GRY	28480	5040-4529
	4040-0749		EXTRACTOR PC BD BRN	14493	5040-5112
	1480-0116		PIN GROOVE #TQ 2#	73957	GP24-063X250-12
A8C1	0160-0174	63	C FXD 0.47UF +80-20% 25WVDC	56289	5C1187S-CML
A8C2	0160-2211	8	C FXD 510PF 5% 300WVDC	72136	RDM19F511J3C
A8C3	0160-0174		C FXD 0.47UF +80-20% 25WVDC	56289	5C1187S-CML
A8C4	0160-2225	9	C FXD 2000PF 5% 300WVDC	72136	RDM19F202J3C
A8C5	0160-0174		C FXD 0.47UF +80-20% 25WVDC	56289	5C1187S-CML
A8C6	0160-2211		C FXD 510PF 5% 300WVDC	72136	RDM19F511J3C
A8C7	0160-0174		C FXD 0.47UF +80-20% 25WVDC	56289	5C1187S-CML
A8C8	0160-2225		C FXD 2000PF 5% 300WVDC	72136	RDM19F202J3C
A8C9	0180-0116		C FXD 6.8UF 10% 35WVDC	56289	150D685X9035B2-DYS
A8C10	0180-0116		C FXD 6.8UF 10% 35WVDC	56289	150D685X9035B2-DYS
A8C11	0160-2218	7	C FXD 1000PF 5% 300WVDC	72136	RDM19F102J3C
A8C12	0160-2218		C FXD 1000PF 5% 300WVDC	72136	RDM19F102J3C
A8C13	0160-2197	4	C FXD 10PF 5% 300WVDC	72136	RDM15C100J3C
A8C14	0160-2198	2	C FXD 20PF 5% 300WVDC	72136	RDM15C200J3C
A8IC1	1810-0120	1	R NETWORK	E0013	58CRX00131R2F
A8IC2	1820-0476	9	IC OPER AMPL	07263	SL21384
A8IC3	1820-0476		IC OPER AMPL	07263	SL21384
A8R1	0698-5542	6	R FXD 20K OHM 1% 1/8W	91637	CMF-1/10-32T-9
A8R2	0757-0458	10	R FXD 51.1K OHM 1% 1/8W	19701	MF4CT-0
A8R3	2100-2517	4	R VAR 50K OHM 10% 1/2W	21030	62-230-1
A8R4	0757-0458		R FXD 51.1K OHM 1% 1/8W	19701	MF4CT-0
A8R5	2100-2517		R VAR 50K OHM 10% 1/2W	21030	62-230-1
A9			WINDOW MULTIPLIER ASSY		
	03720-30009	1	PC BD BLANK #NSR#	E0007	
	4040-0756	1	EXTRACTOR PC BD WHT	28480	5040-5119
	4040-0749		EXTRACTOR PC BD BRN	14493	5040-5112
	1480-0116		PIN GROOVE #TQ 2#	73957	GP24-063X250-12
A9C1	0160-2197		C FXD 10PF 5% 300WVDC	72136	RDM15C100J3C
A9C2	0160-0174		C FXD 0.47UF +80-20% 25WVDC	56289	5C1187S-CML
A9C3	0160-2211		C FXD 510PF 5% 300WVDC	72136	RDM19F511J3C
A9C4	0160-0174		C FXD 0.47UF +80-20% 25WVDC	56289	5C1187S-CML
A9C5	0160-2225		C FXD 2000PF 5% 300WVDC	72136	RDM19F202J3C
A9C6	0180-0116		C FXD 6.8UF 10% 35WVDC	56289	150D685X9035B2-DYS
A9C7	0180-0116		C FXD 6.8UF 10% 35WVDC	56289	150D685X9035B2-DYS
A9C8	0180-0116		C FXD 6.8UF 10% 35WVDC	56289	150D685X9035B2-DYS
A9C9	0160-2218		C FXD 1000PF 5% 300WVDC	72136	RDM19F102J3C
A9C10	0160-2197		C FXD 10PF 5% 300WVDC	72136	RDM15C100J3C

Abbreviations are listed in the introduction to this section

Table 3-1 Replaceable Parts (continued)

Ref Desig	HP Part No	TQ	Description	Mfr	Mfr Part No
A9C11	0160-0174		C FXD 0.47UF +80-20% 25WVDC	56289	5C11B7S-CML
A9C12	0160-0174		C FXD 0.47UF +80-20% 25WVDC	56289	5C11B7S-CML
A9CR1	1901-0040		DIO SI	12065	SG5050
A9CR2	1901-0040		DIO SI	12065	SG5050
A9CR3	1901-0040		DIO SI	12065	SG5050
A9CR4	1901-0040		DIO SI	12065	SG5050
A9CR5	1901-0040		DIO SI	12065	SG5050
A9CR6	1901-0040		DIO SI	12065	SG5050
A9CR7	1901-0040		DIO SI	12065	SG5050
A9CR8	1901-0040		DIO SI	12065	SG5050
A9CR9	1901-0040		DIO SI	12065	SG5050
A9CR10	1901-0040		DIO SI	12065	SG5050
A9CR11	1901-0040		DIO SI	12065	SG5050
A9CR12	1901-0040		DIO SI	12065	SG5050
A9CR13	1901-0040		DIO SI	12065	SG5050
A9CR14	1901-0040		DIO SI	12065	SG5050
A9CR15	1901-0040		DIO SI	12065	SG5050
A9IC1	1820-0476		IC OPER AMPL	07263	SL21384
A9IC2	1826-0021	9	IC VOLTAGE FOLLOWER	12040	SL11611
A9Q1	1854-0019		XSTR SI NPN	13715	S-6516
A9Q2	1853-0036		XSTR SI PNP	04713	#2N3906# SPS-3612
A9Q3	1854-0019		XSTR SI NPN	13715	S-6516
A9Q4	1853-0036		XSTR SI PNP	04713	#2N3906# SPS-3612
A9Q5	1854-0019		XSTR SI NPN	13715	S-6516
A9Q6	1853-0036		XSTR SI PNP	04713	#2N3906# SPS-3612
A9Q7	1854-0019		XSTR SI NPN	13715	S-6516
A9Q8	1853-0036		XSTR SI PNP	04713	#2N3906# SPS-3612
A9Q9	1854-0019		XSTR SI NPN	13715	S-6516
A9Q10	1853-0036		XSTR SI PNP	04713	#2N3906# SPS-3612
A9Q11	1854-0019		XSTR SI NPN	13715	S-6516
A9Q12	1853-0036		XSTR SI PNP	04713	#2N3906# SPS-3612
A9Q13	1854-0019		XSTR SI NPN	13715	S-6516
A9Q14	1853-0036		XSTR SI PNP	04713	#2N3906# SPS-3612
A9Q15	1855-0020		XSTR FET N-CHANNEL	21845	F1151
A9Q16	1855-0082	15	XSTR FET P-CHANNEL	04713	SS3723
A9Q17	1855-0020		XSTR FET N-CHANNEL	21845	F1151
A9Q18	1855-0082		XSTR FET P-CHANNEL	04713	SS3723
A9Q19	1855-0020		XSTR FET N-CHANNEL	21845	F1151
A9Q20	1855-0082		XSTR FET P-CHANNEL	04713	SS3723
A9Q21	1855-0020		XSTR FET N-CHANNEL	21845	F1151
A9Q22	1855-0082		XSTR FET P-CHANNEL	04713	SS3723
A9Q23	1855-0389	9	XSTR FET N-CHANNEL	17856	WN041
A9Q24	1855-0082		XSTR FET P-CHANNEL	04713	SS3723
A9Q25	1855-0389		XSTR FET N-CHANNEL	17856	WN041
A9Q26	1855-0082		XSTR FET P-CHANNEL	04713	SS3723
A9Q27	1855-0389		XSTR FET N-CHANNEL	17856	WN041
A9Q28	1855-0082		XSTR FET P-CHANNEL	04713	SS3723
A9Q29	1854-0019		XSTR SI NPN	13715	S-6516
A9Q30	1853-0036		XSTR SI PNP	04713	#2N3906# SPS-3612
A9Q31	1855-0020		XSTR FET N-CHANNEL	21845	F1151
A9Q32	1854-0019		XSTR SI NPN	13715	S-6516
A9R1	0698-5490		R FXD 2K OHM 1% 1/8W	91637	CMF-1/10-32T-2
A9R2	0698-5490		R FXD 2K OHM 1% 1/8W	91637	CMF-1/10-32T-2
A9R3	0698-3446		R FXD 383 OHM 1% 1/8W	19701	MF4CT-0

Abbreviations are listed in the introduction to this section

Table 3-1 Replaceable Parts (continued)

Ref Desig	HP Part No	TQ	Description	Mfr	Mfr Part No
A9R4	0698-0085	19	R FXD 2.61K OHM 1% 1/8W	19701	MF4CT-0
A9R5	0757-0750		R FXD 6.81K OHM 1% 1/4W	19701	MF52CT-0
A9R6	0698-5490		R FXD 2K OHM 1% 1/8W	91637	CMF-1/10-32T-2
A9R7	0698-5490		R FXD 2K OHM 1% 1/8W	91637	CMF-1/10-32T-2
A9R8	0698-3446		R FXD 383 OHM 1% 1/8W	19701	MF4CT-0
A9R9	0698-0085		R FXD 2.61K OHM 1% 1/8W	19701	MF4CT-0
A9R10	0757-0750		R FXD 6.81K OHM 1% 1/4W	19701	MF52CT-0
A9R11	0698-5490		R FXD 2K OHM 1% 1/8W	91637	CMF-1/10-32T-2
A9R12	0698-5490		R FXD 2K OHM 1% 1/8W	91637	CMF-1/10-32T-2
A9R13	0698-3446		R FXD 383 OHM 1% 1/8W	19701	MF4CT-0
A9R14	0698-0085		R FXD 2.61K OHM 1% 1/8W	19701	MF4CT-0
A9R15	0757-0750		R FXD 6.81K OHM 1% 1/4W	19701	MF52CT-0
A9R16	0698-5490		R FXD 2K OHM 1% 1/8W	91637	CMF-1/10-32T-2
A9R17	0698-5490		R FXD 2K OHM 1% 1/8W	91637	CMF-1/10-32T-2
A9R18	0698-3446		R FXD 383 OHM 1% 1/8W	19701	MF4CT-0
A9R19	0698-0085		R FXD 2.61K OHM 1% 1/8W	19701	MF4CT-0
A9R20	0757-0750		R FXD 6.81K OHM 1% 1/4W	19701	MF52CT-0
A9R21	0698-5490		R FXD 2K OHM 1% 1/8W	91637	CMF-1/10-32T-2
A9R22	0698-5490		R FXD 2K OHM 1% 1/8W	91637	CMF-1/10-32T-2
A9R23	0698-3446		R FXD 383 OHM 1% 1/8W	19701	MF4CT-0
A9R24	0698-0085		R FXD 2.61K OHM 1% 1/8W	19701	MF4CT-0
A9R25	0757-0750		R FXD 6.81K OHM 1% 1/4W	19701	MF52CT-0
A9R26	0698-5490		R FXD 2K OHM 1% 1/8W	91637	CMF-1/10-32T-2
A9R27	0698-5490		R FXD 2K OHM 1% 1/8W	91637	CMF-1/10-32T-2
A9R28	0698-3446		R FXD 383 OHM 1% 1/8W	19701	MF4CT-0
A9R29	0698-0085		R FXD 2.61K OHM 1% 1/8W	19701	MF4CT-0
A9R30	0757-0750		R FXD 6.81K OHM 1% 1/4W	19701	MF52CT-0
A9R31	0698-5490		R FXD 2K OHM 1% 1/8W	91637	CMF-1/10-32T-2
A9R32	0698-5490		R FXD 2K OHM 1% 1/8W	91637	CMF-1/10-32T-2
A9R33	0698-3446		R FXD 383 OHM 1% 1/8W	19701	MF4CT-0
A9R34	0698-0085		R FXD 2.61K OHM 1% 1/8W	19701	MF4CT-0
A9R35	0757-0750		R FXD 6.81K OHM 1% 1/4W	19701	MF52CT-0
A9R36	0757-0465		R FXD 100K OHM 1% 1/8W	19701	MF4CT-0
A9R37	0757-0465		R FXD 100K OHM 1% 1/8W	19701	MF4CT-0
A9R38	0757-0465		R FXD 100K OHM 1% 1/8W	19701	MF4CT-0
A9R39	0757-0465		R FXD 100K OHM 1% 1/8W	19701	MF4CT-0
A9R40	0757-0465		R FXD 100K OHM 1% 1/8W	19701	MF4CT-0
A9R40	0757-0465		R FXD 100K OHM 1% 1/8W	19701	MF4CT-0
A9R41	0757-0465		R FXD 100K OHM 1% 1/8W	19701	MF4CT-0
A9R42	0757-0465		R FXD 100K OHM 1% 1/8W	19701	MF4CT-0
A9R43	0757-0465		R FXD 100K OHM 1% 1/8W	19701	MF4CT-0
A9R44	0757-0465		R FXD 100K OHM 1% 1/8W	19701	MF4CT-0
A9R45	0757-0465		R FXD 100K OHM 1% 1/8W	19701	MF4CT-0
A9R46	0757-0465		R FXD 100K OHM 1% 1/8W	19701	MF4CT-0
A9R47	0757-0465		R FXD 100K OHM 1% 1/8W	19701	MF4CT-0
A9R48	0757-0465		R FXD 100K OHM 1% 1/8W	19701	MF4CT-0
A9R49	0757-0465		R FXD 100K OHM 1% 1/8W	19701	MF4CT-0
A9R50	0698-8204	3	R FXD 7.98K OHM 0.1% 1/8W	19701	MF4CT-9
A9R51	0698-8205	4	R FXD 15.98K OHM 0.1% 1/8W	19701	MF4CT-9
A9R52	0698-8047	9	R FXD 32K OHM 0.1% 1/8W	19701	MF4CT-9
A9R53	0698-8049	13	R FXD 64K OHM 0.1% 1/8W	19701	MF4CT-9
A9R54	0698-8053	3	R FXD 128K OHM 0.1% 1/8W	75042	CCAT-9
A9R55	0698-8050	3	R FXD 256K OHM 0.1% 1/8W	19701	MF4CT-9
A9R56	0698-8051	6	R FXD 512K OHM 0.1% 1/8W	75042	CCAT-9
A9R57	0698-5490		R FXD 2K OHM 1% 1/8W	91637	CMF-1/10-32T-2

Abbreviations are listed in the introduction to this section

Table 3-1 Replaceable Parts (continued)

Ref Desig	HP Part No	TQ	Description	Mfr	Mfr Part No
A9R58	0698-5490		R FXD 2K OHM 1% 1/8W	91637	CMF-1/10-32T-2
A9R59	0698-3446		R FXD 383 OHM 1% 1/8W	19701	MF4CT-0
A9R60	0698-0085		R FXD 2.61K OHM 1% 1/8W	19701	MF4CT-0
A9R61	0757-0750		R FXD 6.81K OHM 1% 1/4W	19701	MF52CT-0
A9R62	0757-0465		R FXD 100K OHM 1% 1/8W	19701	MF4CT-0
A9R63	0698-8043	1	R FXD 6.6K OHM 1% 1/8W	19701	MF4CT-9
A9R64	0757-0458		R FXD 51.1K OHM 1% 1/8W	19701	MF4CT-0
A9R65	2100-2517		R VAR 50K OHM 10% 1/2W	21030	62-230-1
A9R66	0757-0442	28	R FXD 10K OHM 1% 1/8W	19701	MF4C
A9R67	0757-0442		R FXD 10K OHM 1% 1/8W	19701	MF4C
A9R68	0757-0438	15	R FXD 5.11K OHM 1% 1/8W	19701	MF4CT-0
A9R69	0757-0401	7	R FXD 100 OHM 1% 1/8W	19701	MF4CT-0
A9R70	0757-0442		R FXD 10K OHM 1% 1/8W	19701	MF4C
A9R71	0757-0280		R FXD 1K OHM 1% 1/8W	75042	CEAT-0
A10			INTEGRATER ASSY		
	03720-30010	1	PC BD BLANK #NSR#	E0007	
	4040-0748		EXTRACTOR PC BD BLK	28480	5040-5111
	4040-0749		EXTRACTOR PC BD BRN	14493	5040-5112
	1480-0116		PIN GROOVE #TQ 2#	73957	GP24-063X250-12
A10C1	0170-0066	2	C FXD 0.027UF 10% 200WVDC	56289	192P27392-PTS
A10C2	0160-0174		C FXD 0.47UF +80-20% 25WVDC	56289	5C11B7S-CML
A10C3	0160-0174		C FXD 0.47UF +80-20% 25WVDC	56289	5C11B7S-CML
A10C4	0160-2230	4	C FXD 3300PF 5% 300WVDC	72136	
A10C5	0160-2211		C FXD 510PF 5% 300WVDC	72136	RDM19F511J3C
A10C6	0160-2225		C FXD 2000PF 5% 300WVDC	72136	RDM19F202J3C
A10C7	0160-2307	1	C FXD 47PF 5% 300WVDC	72136	RDM15E470J3C
A10C8	0160-2218		C FXD 1000PF 5% 300WVDC	72136	RDM19F102J3C
A10C9	0160-2230		C FXD 3300PF 5% 300WVDC	72136	
A10C10	0160-0174		C FXD 0.47UF +80-20% 25WVDC	56289	5C11B7S-CML
A10C11	0160-0174		C FXD 0.47UF +80-20% 25WVDC	56289	5C11B7S-CML
A10C12	0160-2230		C FXD 3300PF 5% 300WVDC	72136	
A10C13	0160-0174		C FXD 0.47UF +80-20% 25WVDC	56289	5C11B7S-CML
A10C14	0160-0174		C FXD 0.47UF +80-20% 25WVDC	56289	5C11B7S-CML
A10C15	0160-0174		C FXD 0.47UF +80-20% 25WVDC	56289	5C11B7S-CML
A10C16	0160-0174		C FXD 0.47UF +80-20% 25WVDC	56289	5C11B7S-CML
A10C17	0160-2199	15	C FXD 30PF 5% 300WVDC	72136	RDM15E300J3C
A10C18	0140-0070	2	C FXD 0.01UF 1% 500WVDC	14655	RCM35E103F#300V#
A10C19	0160-0174		C FXD 0.47UF +80-20% 25WVDC	56289	5C11B7S-CML
A10C20	0160-0174		C FXD 0.47UF +80-20% 25WVDC	56289	5C11B7S-CML
A10C21	0140-0070		C FXD 0.01UF 1% 500WVDC	14655	RCM35E103F#300V#
A10C22	0160-0174		C FXD 0.47UF +80-20% 25WVDC	56289	5C11B7S-CML
A10C23	0160-0174		C FXD 0.47UF +80-20% 25WVDC	56289	5C11B7S-CML
A10C24	0160-0174		C FXD 0.47UF +80-20% 25WVDC	56289	5C11B7S-CML
A10C25	0180-0116		C FXD 6.8UF 10% 35WVDC	56289	150D685X9035B2-DYS
A10C26	0180-0116		C FXD 6.8UF 10% 35WVDC	56289	150D685X9035B2-DYS
A10C27	0180-0116		C FXD 6.8UF 10% 35WVDC	56289	150D685X9035B2-DYS
A10C28	0180-0116		C FXD 6.8UF 10% 35WVDC	56289	150D685X9035B2-DYS
A10CR1	1901-0040		DIO SI	12065	SG5050
A10CR2	1901-0040		DIO SI	12065	SG5050
A10CR3	1901-0040		DIO SI	12065	SG5050
A10CR4	1901-0040		DIO SI	12065	SG5050
A10CR5	1901-0040		DIO SI	12065	SG5050

Abbreviations are listed in the introduction to this section

Table 3-1 Replaceable Parts (continued)

Ref Desig	HP Part No	TQ	Description	Mfr	Mfr Part No
A10CR6	1902-3059	3	DIO BKDN 3.83V 5% 400MW	07910	CD 35586
A10IC1	1820-0476		IC OPER AMPL	07263	SL21384
A10IC2	1826-0021		IC VOLTAGE FOLLOWER	12040	SL11611
A10IC3	1826-0021		IC VOLTAGE FOLLOWER	12040	SL11611
A10IC4	1820-0477	17	IC OPER AMPL	01295	SN19731
A10IC5	1826-0021		IC VOLTAGE FOLLOWER	12040	SL11611
A10IC6	1826-0021		IC VOLTAGE FOLLOWER	12040	SL11611
A10MC11	1820-0261		IC MONOSTABLE	E0001	SN74121N
A10MC21	1820-0068		IC TRIPLE 3-1/P NAND GATE	E0001	SN4343
A10MC22	1820-0054		IC QUAD 2-1/P NAND GATE	E0001	SN4342
A10MC23	1820-0069		IC DUAL 4-1/P NAND GATE	E0001	SN4344
A10MC24	1820-0054		IC QUAD 2-1/P NAND GATE	E0001	SN4342
A10Q1	1855-0020		XSTR FET N-CHANNEL	21845	F1151
A10Q2	1855-0081	9	XSTR FET N-CHANNEL	E0001	2N5245
A10Q3	1855-0081		XSTR FET N-CHANNEL	E0001	2N5245
A10Q4	1855-0020		XSTR FET N-CHANNEL	21845	F1151
A10Q5	1855-0020		XSTR FET N-CHANNEL	21845	F1151
A10Q6	1854-0019		XSTR SI NPN	13715	S-6516
A10Q7	1854-0019		XSTR SI NPN	13715	S-6516
A10Q8	1853-0036		XSTR SI PNP	04713	#2N3906# SPS-3612
A10Q9	1854-0019		XSTR SI NPN	13715	S-6516
A10Q10	1853-0036		XSTR SI PNP	04713	#2N3906# SPS-3612
A10Q11	1853-0036		XSTR SI PNP	04713	#2N3906# SPS-3612
A10Q12	1854-0019		XSTR SI NPN	13715	S-6516
A10Q13	1854-0019		XSTR SI NPN	13715	S-6516
A10Q14	1853-0036		XSTR SI PNP	04713	#2N3906# SPS-3612
A10Q15	1853-0036		XSTR SI PNP	04713	#2N3906# SPS-3612
A10Q16	1854-0019		XSTR SI NPN	13715	S-6516
A10R1	0698-6631	1	R FXD 2.5K OHM 0.1% 1/8W	19701	MF4CT-9
A10R2	0698-6320	1	R FXD 5K OHM 0.1% 1/8W	91637	CMF-1/10-32T-9
A10R3	0698-6360	10	R FXD 10K OHM 0.1% 1/8W	75042	CEAT-9
A10R4	0698-6630	1	R FXD 20K OHM 0.1% 1/8W	19701	MF4CT-9
A10R5	0698-6627	1	R FXD 25K OHM 0.1% 1/8W	19701	MF4CT-9
A10R6	0698-6353	1	R FXD 50K OHM 0.1% 1/8W	75042	CEAT-9
A10R7	0698-6358	1	R FXD 100K OHM 0.1% 1/8W	75042	CEAT-9
A10R8	0698-6376	1	R FXD 200K OHM 0.1% 1/8W	91637	CMF-1/10-32T-9
A10R9	0698-6621	1	R FXD 250K OHM 0.1% 1/8W	19701	MF4CT-9
A10R10	0698-6628	1	R FXD 500K OHM 0.1% 1/8W	75042	CEAT-9
A10R11	0757-0394	5	R FXD 51.1 OHM 1% 1/8W	19701	MF4CT-0
A10R12	2100-2517		R VAR 50K OHM 10% 1/2W	21030	62-230-1
A10R13	0757-0416		R FXD 511 OHM 1% 1/8W	19701	MF4CT-0
A10R14	0757-0465		R FXD 100K OHM 1% 1/8W	19701	MF4CT-0
A10R15	0757-0458		R FXD 51.1K OHM 1% 1/8W	19701	MF4CT-0
A10R16	0698-3136	6	R FXD 17.8K OHM 1% 1/8W	19701	MF4CT-0
A10R17	0757-0465		R FXD 100K OHM 1% 1/8W	19701	MF4CT-0
A10R18	0757-0420	3	R FXD 750 OHM 1% 1/8W	19701	MF4CT-0
A10R19	0757-0465		R FXD 100K OHM 1% 1/8W	19701	MF4CT-0
A10R20	0757-0465		R FXD 100K OHM 1% 1/8W	19701	MF4CT-0
A10R21	0698-6360		R FXD 10K OHM 0.1% 1/8W	75042	CEAT-9
A10R22	0698-6360		R FXD 10K OHM 0.1% 1/8W	75042	CEAT-9
A10R23	0698-6360		R FXD 10K OHM 0.1% 1/8W	75042	CEAT-9
A10R24	0698-6360		R FXD 10K OHM 0.1% 1/8W	75042	CEAT-9
A10R25	0757-0465		R FXD 100K OHM 1% 1/8W	19701	MF4CT-0
A10R26	0757-0394		R FXD 51.1 OHM 1% 1/8W	19701	MF4CT-0

Abbreviations are listed in the introduction to this section

Table 3-1 Replaceable Parts (continued)

Ref Desig	HP Part No	TQ	Description	Mfr	Mfr Part No
A10R27	2100-2633	8	R VAR 1K 10% 1/2W LIN	21030	62-224-1
A10R28	0757-0465		R FXD 100K OHM 1% 1/8W	19701	MF4CT-0
A10R29	0757-0394		R FXD 51.1 OHM 1% 1/8W	19701	MF4CT-0
A10R30	2100-2633		R VAR 1K 10% 1/2W LIN	21030	62-224-1
A10R31	0757-0394		R FXD 51.1 OHM 1% 1/8W	19701	MF4CT-0
A10R32	0757-0416		R FXD 511 OHM 1% 1/8W	19701	MF4CT-0
A10R33	0698-5490		R FXD 2K OHM 1% 1/8W	91637	CMF-1/10-32T-2
A10R34	0698-5490		R FXD 2K OHM 1% 1/8W	91637	CMF-1/10-32T-2
A10R35	0698-3446		R FXD 383 OHM 1% 1/8W	19701	MF4CT-0
A10R36	0698-3153		R FXD 3.83K OHM 1% 1/8W	19701	MF4CT-0
A10R37	0757-0750		R FXD 6.81K OHM 1% 1/4W	19701	MF52CT-0
A10R38	0698-5490		R FXD 2K OHM 1% 1/8W	91637	CMF-1/10-32T-2
A10R39	0698-5490		R FXD 2K OHM 1% 1/8W	91637	CMF-1/10-32T-2
A10R40	0698-3446		R FXD 383 OHM 1% 1/8W	19701	MF4CT-0
A10R41	0698-3153		R FXD 3.83K OHM 1% 1/8W	19701	MF4CT-0
A10R42	0757-0750		R FXD 6.81K OHM 1% 1/4W	19701	MF52CT-0
A10R43	0757-0750		R FXD 6.81K OHM 1% 1/4W	19701	MF52CT-0
A10R44	0698-3446		R FXD 383 OHM 1% 1/8W	19701	MF4CT-0
A10R45	0698-3153		R FXD 3.83K OHM 1% 1/8W	19701	MF4CT-0
A10R46	0698-5490		R FXD 2K OHM 1% 1/8W	91637	CMF-1/10-32T-2
A10R47	0698-5490		R FXD 2K OHM 1% 1/8W	91637	CMF-1/10-32T-2
A10R48	0698-5490		R FXD 2K OHM 1% 1/8W	91637	CMF-1/10-32T-2
A10R49	0698-5490		R FXD 2K OHM 1% 1/8W	91637	CMF-1/10-32T-2
A10R50	0698-3446		R FXD 383 OHM 1% 1/8W	19701	MF4CT-0
A10R51	0698-3153		R FXD 3.83K OHM 1% 1/8W	19701	MF4CT-0
A10R52	0757-0750		R FXD 6.81K OHM 1% 1/4W	19701	MF52CT-0
A10R53	0757-0750		R FXD 6.81K OHM 1% 1/4W	19701	MF52CT-0
A10R54	0698-3446		R FXD 383 OHM 1% 1/8W	19701	MF4CT-0
A10R55	0698-3153		R FXD 3.83K OHM 1% 1/8W	19701	MF4CT-0
A10R56	0698-5490		R FXD 2K OHM 1% 1/8W	91637	CMF-1/10-32T-2
A10R57	0698-5490		R FXD 2K OHM 1% 1/8W	91637	CMF-1/10-32T-2
A10R58	0698-3450	1	R FXD 42.2K OHM 1% 1/8W	19701	MF4CT-0
A11			POLAR CONVERTER ASSY		
	03720-30011	1	PC BD BLANK #NSR#	E0007	
	4040-0749		EXTRACTOR PC BD BRN	14493	5040-5112
	4040-0749		EXTRACTOR PC BD BRN	14493	5040-5112
	1480-0116		PIN GROOVE #TQ 2#	73957	GP24-063X250-12
A11C1			NUT ASSIGNED		
A11C2	0121-0036	2	C VAR 5.5-18PF	20846	538-006A55-18
A11C3			NOT ASSIGNED		
A11C4	0121-0036		C VAR 5.5-18PF	20846	538-006A55-18
A11C5	0160-0174		C FXD 0.47UF +80-20% 25WVDC	56289	5C11B7S-CML
A11C6	0160-2199		C FXD 30PF 5% 300WVDC	72136	RDM15E300J3C
A11C7	0160-3975	1	C FXD 0.03UF 1% 125V	E0007	
A11C8	0160-0174		C FXD 0.47UF +80-20% 25WVDC	56289	5C11B7S-CML
A11C9	0140-0198	1	C FXD 200PF 5% 300WVDC	72136	RDM15F201J3C
A11C10	0160-0174		C FXD 0.47UF +80-20% 25WVDC	56289	5C11B7S-CML
A11C11	0160-0174		C FXD 0.47UF +80-20% 25WVDC	56289	5C11B7S-CML
A11C12	0140-0196	2	C FXD 150PF 5% 300WVDC	72136	RDM15F151J3C
A11C13	0160-2244	1	C FXD 3PF 0.25PF 500WVDC	72982	301-NPO-30PF 0 25#PF#
A11C14	0160-0174		C FXD 0.47UF +80-20% 25WVDC	56289	5C11B7S-CML
A11C15	0160-0174		C FXD 0.47UF +80-20% 25WVDC	56289	5C11B7S-CML
A11C16			NOT ASSIGNED		

Abbreviations are listed in the introduction to this section

Table 3-1 Replaceable Parts (continued)

Ref Desig	HP Part No	TQ	Description	Mfr	Mfr Part No
A11C17	0160-0161	7	C FXD 0.01UF 10% 200WVDC	56289	192P10392-PTS
A11C18	0160-0174		C FXD 0.47UF +80-20% 25WVDC	56289	5C11B7S-CML
A11C19	0160-0174		C FXD 0.47UF +80-20% 25WVDC	56289	5C11B7S-CML
A11C20	0160-0155	1	C FXD 3300PF 10% 200WVDC	56289	192P33292-PTS
A11C21	0160-0174		C FXD 0.47UF +80-20% 25WVDC	56289	5C11B7S-CML
A11C22	0160-2197		C FXD 10PF 5% 300WVDC	72136	RDM15C100J3C
A11C23	0160-0174		C FXD 0.47UF +80-20% 25WVDC	56289	5C11B7S-CML
A11C24	0160-2227	1	C FXD 2400PF 5% 300WVDC	72136	RDM19F242J3C
A11C25	0160-2225		C FXD 2000PF 5% 300WVDC	72136	RDM19F202J3C
A11C26	0160-2230		C FXD 3300PF 5% 300WVDC	72136	
A11C27	0160-0174		C FXD 0.47UF +80-20% 25WVDC	56289	5C11B7S-CML
A11C28	0160-2199		C FXD 30PF 5% 300WVDC	72136	RDM15E300J3C
A11C29	0160-0174		C FXD 0.47UF +80-20% 25WVDC	56289	5C11B7S-CML
A11C30	0160-0161		C FXD 0.01UF 10% 200WVDC	56289	192P10392-PTS
A11C31	0160-0174		C FXD 0.47UF +80-20% 25WVDC	56289	5C11B7S-CML
A11C32	0160-0174		C FXD 0.47UF +80-20% 25WVDC	56289	5C11B7S-CML
A11C33	0180-0116		C FXD 6.8UF 10% 35WVDC	56289	150D685X9035B2-DYS
A11C34	0180-0116		C FXD 6.8UF 10% 35WVDC	56289	150D685X9035B2-DYS
A11C35	0180-0116		C FXD 6.8UF 10% 35WVDC	56289	150D685X9035B2-DYS
A11C36	0180-0116		C FXD 6.8UF 10% 35WVDC	56289	150D685X9035B2-DYS
A11CR1	1901-0040		DIO SI	12065	SG5050
A11CR2	1901-0040		DIO SI	12065	SG5050
A11CR3	1901-0040		DIO SI	12065	SG5050
A11CR4	1901-0040		DIO SI	12065	SG5050
A11CR5	1901-0040		DIO SI	12065	SG5050
A11CR6	1902-3059		DIO BKDN 3.83V 5% 400MW	07910	GD 35586
A11CR7	1901-0040		DIO SI	12065	SG5050
A11CR8	1901-0040		DIO SI	12065	SG5050
A11CR9	1902-0509	8	DIO BKDN 6.2V 2% TEMP COMP	04713	SZ12250
A11CR10	1902-0509		DIO BKDN 6.2V 2% TEMP COMP	04713	SZ12250
A11CR11	1901-0040		DIO SI	12065	SG5050
A11CR12	1901-0040		DIO SI	12065	SG5050
A11CR13	1901-0040		DIO SI	12065	SG5050
A11IC1	1820-0477		IC OPER AMPL	01295	SN19Z31
A11IC2	1826-0021		IC VOLTAGE FOLLOWER	12040	SL11611
A11IC3	1820-0477		IC OPER AMPL	01295	SN19Z31
A11IC4	1826-0021		IC VOLTAGE FOLLOWER	12040	SL11611
A11IC5	1820-0476		IC OPER AMPL	07263	SL21384
A11IC6	1820-0477		IC OPER AMPL	01295	SN19Z31
A11IC7	1826-0021		IC VOLTAGE FOLLOWER	12040	SL11611
A11L1	03720-70056	1	IND VAR 10MH	E0007	03720-70056
A11MC11	1820-0261		IC MONOSTABLE	E0001	SN74121N
A11MC12	1820-0055	4	IC DECADE COUNTER	E0001	SN4356
A11MC13	1820-0054		IC QUAD 2-I/P NAND GATE	E0001	SN4342
A11MC14	1820-0077		IC DUAL D-TYPE FLIP-FLOP	E0001	SN4354
A11MC15	1820-0077		IC DUAL D-TYPE FLIP-FLOP	E0001	SN4354
A11MC21	1820-0261		IC MONOSTABLE	E0001	SN74121N
A11MC22	1820-0077		IC DUAL D-TYPE FLIP-FLOP	E0001	SN4354
A11MC23	1820-0054		IC QUAD 2-I/P NAND GATE	E0001	SN4342
A11MC24	1820-0084		IC 4-WIDE 2-I/P AND/INV +XR GATE	E0001	SN4349
A11Q1	1855-0081		XSTR FET N-CHANNEL	E0001	2N5245
A11Q2	1855-0082		XSTR FET P-CHANNEL	04713	SS3723
A11Q3	1853-0036		XSTR SI PNP	04713	#2N3906# SPS-3612

Abbreviations are listed in the introduction to this section

Table 3-1 Replaceable Parts (continued)

Ref Desig	HP Part No	TQ	Description	Mfr	Mfr Part No
A11Q4	1854-0019		XSTR SI NPN	13715	S-6516
A11Q5	1855-0081		XSTR FET N-CHANNEL	E0001	2N5245
A11Q6	1855-0082		XSTR FET P-CHANNEL	04713	SS3723
A11Q7	1853-0036		XSTR SI PNP	04713	#2N3906# SPS-3612
A11Q8	1854-0019		XSTR SI NPN	13715	S-6516
A11Q9	1855-0081		XSTR FET N-CHANNEL	E0001	2N5245
A11Q10	1854-0019		XSTR SI NPN	13715	S-6516
A11Q11	1853-0036		XSTR SI PNP	04713	#2N3906# SPS-3612
A11Q12	1854-0019		XSTR SI NPN	13715	S-6516
A11Q13	1853-0036		XSTR SI PNP	04713	#2N3906# SPS-3612
A11Q14	1854-0019		XSTR SI NPN	13715	S-6516
A11Q15	1853-0036		XSTR SI PNP	04713	#2N3906# SPS-3612
A11Q16	1854-0019		XSTR SI NPN	13715	S-6516
A11Q17	1853-0036		XSTR SI PNP	04713	#2N3906# SPS-3612
A11Q18	1855-0081		XSTR FET N-CHANNEL	E0001	2N5245
A11Q19	1855-0082		XSTR FET P-CHANNEL	04713	SS3723
A11Q20	1855-0020		XSTR FET N-CHANNEL	21845	F1151
A11Q21	1855-0020		XSTR FET N-CHANNEL	21845	F1151
A11Q22	1855-0081		XSTR FET N-CHANNEL	E0001	2N5245
A11R1	0757-0465		R FXD 100K OHM 1% 1/8W	19701	MF4CT-0
A11R2	0757-0465		R FXD 100K OHM 1% 1/8W	19701	MF4CT-0
A11R3	0757-0438		R FXD 5.11K OHM 1% 1/8W	19701	MF4CT-0
A11R4	0757-0750		R FXD 6.81K OHM 1% 1/4W	19701	MF52CT-0
A11R5	0698-3446		R FXD 383 OHM 1% 1/8W	19701	MF4CT-0
A11R6	0698-0085		R FXD 2.61K OHM 1% 1/8W	19701	MF4CT-0
A11R7	0698-5490		R FXD 2K OHM 1% 1/8W	91637	CMF-1/10-32T-2
A11R8	0698-5490		R FXD 2K OHM 1% 1/8W	91637	CMF-1/10-32T-2
A11R9	0757-0465		R FXD 100K OHM 1% 1/8W	19701	MF4CT-0
A11R10	0757-0465		R FXD 100K OHM 1% 1/8W	19701	MF4CT-0
A11R11	0757-0438		R FXD 5.11K OHM 1% 1/8W	19701	MF4CT-0
A11R12	0757-0750		R FXD 6.81K OHM 1% 1/4W	19701	MF52CT-0
A11R13	0698-3446		R FXD 383 OHM 1% 1/8W	19701	MF4CT-0
A11R14	0698-0085		R FXD 2.61K OHM 1% 1/8W	19701	MF4CT-0
A11R15	0698-5490		R FXD 2K OHM 1% 1/8W	91637	CMF-1/10-32T-2
A11R16	0698-5490		R FXD 2K OHM 1% 1/8W	91637	CMF-1/10-32T-2
A11R17	2100-2516	2	R VAR 100K OHM 1% 1/2W	21030	
A11R18			NOT ASSIGNED		
A11R19	0757-0438		R FXD 5.11K OHM 1% 1/8W	19701	MF4CT-0
A11R20	2100-2521	6	R VAR 2K OHM 10% 1/2W LIN	73138	62-225-1
A11R21	0757-0442		R FXD 10K OHM 1% 1/8W	19701	MF4C
A11R22	0757-0465		R FXD 100K OHM 1% 1/8W	19701	MF4CT-0
A11R23	2100-2633		R VAR 1K 10% 1/2W LIN	21030	62-224-1
A11R24	0757-0442		R FXD 10K OHM 1% 1/8W	19701	MF4C
A11R25	0698-5490		R FXD 2K OHM 1% 1/8W	91637	CMF-1/10-32T-2
A11R26	2100-2522	2	R VAR 10K OHM 10% 1/2W LIN	73138	62-227-1
A11R27	0698-3159	8	R FXD 26.1K OHM 1% 1/8W	19701	MF4CT-0
A11R28	0698-5490		R FXD 2K OHM 1% 1/8W	91637	CMF-1/10-32T-2
A11R29	0698-5490		R FXD 2K OHM 1% 1/8W	91637	CMF-1/10-32T-2
A11R30	0698-3446		R FXD 383 OHM 1% 1/8W	19701	MF4CT-0
A11R31	0698-0085		R FXD 2.61K OHM 1% 1/8W	19701	MF4CT-0
A11R32	0757-0750		R FXD 6.81K OHM 1% 1/4W	19701	MF52CT-0
A11R33	0698-5490		R FXD 2K OHM 1% 1/8W	91637	CMF-1/10-32T-2
A11R34	0698-5490		R FXD 2K OHM 1% 1/8W	91637	CMF-1/10-32T-2
A11R35	0698-3446		R FXD 383 OHM 1% 1/8W	19701	MF4CT-0
A11R36	0698-0085		R FXD 2.61K OHM 1% 1/8W	19701	MF4CT-0

Abbreviations are listed in the introduction to this section

Table 3-1 Replaceable Parts (continued)

Ref Desig	HP Part No	TQ	Description	Mfr	Mfr Part No
A11R37	0757-0750		R FXD 6.81K OHM 1% 1/4W	19701	MF52CT-0
A11R38	0698-5490		R FXD 2K OHM 1% 1/8W	91637	CMF-1/10-32T-2
A11R39	0698-5490		R FXD 2K OHM 1% 1/8W	91637	CMF-1/10-32T-2
A11R40	0698-3446		R FXD 383 OHM 1% 1/8W	19701	MF4CT-0
A11R41	0698-0085		R FXD 2.61K OHM 1% 1/8W	19701	MF4CT-0
A11R42	0757-0750		R FXD 6.81K OHM 1% 1/4W	19701	MF52CT-0
A11R43	0698-5490		R FXD 2K OHM 1% 1/8W	91637	CMF-1/10-32T-2
A11R44	0698-5490		R FXD 2K OHM 1% 1/8W	91637	CMF-1/10-32T-2
A11R45	0698-3446		R FXD 383 OHM 1% 1/8W	19701	MF4CT-0
A11R46	0698-0085		R FXD 2.61K OHM 1% 1/8W	19701	MF4CT-0
A11R47	0757-0750		R FXD 6.81K OHM 1% 1/4W	19701	MF52CT-0
A11R48	0757-0465		R FXD 100K OHM 1% 1/8W	19701	MF4CT-0
A11R49	0757-0465		R FXD 100K OHM 1% 1/8W	19701	MF4CT-0
A11R50	0698-5490		R FXD 2K OHM 1% 1/8W	91637	CMF-1/10-32T-2
A11R51	0757-0465		R FXD 100K OHM 1% 1/8W	19701	MF4CT-0
A11R52	2100-2522		R VAR 10K OHM 10% 1/2W LIN	73138	62-227-1
A11R53	0757-0442		R FXD 10K OHM 1% 1/8W	19701	MF4C
A11R54	0757-0465		R FXD 100K OHM 1% 1/8W	19701	MF4CT-0
A11R55	0757-0465		R FXD 100K OHM 1% 1/8W	19701	MF4CT-0
A11R56	0757-0280		R FXD 1K OHM 1% 1/8W	75042	CEAT-0
A11R57	0757-0280		R FXD 1K OHM 1% 1/8W	75042	CEAT-0
A11R58	0757-0280		R FXD 1K OHM 1% 1/8W	75042	CEAT-0
A11R59	0698-3159		R FXD 26.1K OHM 1% 1/8W	19701	MF4CT-0
A11R60	0757-0394		R FXD 51.1 OHM 1% 1/8W	19701	MF4CT-0
A11R61	0698-3158	1	R FXD 23.7K OHM 1% 1/8W	19701	MF4CT-0
A12			LOW VOLTAGE POWER SUPPLY ASSY		
	03720-30012	1	PC BD BLANK #NSR#	E0007	
	4040-0750		EXTRACTOR PC BD RED	14493	5040-5113
	4040-0749		EXTRACTOR PC BD BRN	14493	5040-5112
	1480-0116		PIN GROOVE #TQ 2#	73957	GP24-063X250-12
A12C1	0160-0161		C FXD 0.01UF 10% 200WVDC	56289	192P10392-PTS
A12C2	0180-0089	4	C FXD 10UF +50-10% 150WVDC	56289	30D 106F 150DD2DSM
A12C3	0160-0161		C FXD 0.01UF 10% 200WVDC	56289	192P10392-PTS
A12C4	0160-0161		C FXD 0.01UF 10% 200WVDC	56289	192P10392-PTS
A12C5	0180-0089		C FXD 10UF +50-10% 150WVDC	56289	30D 106F 150DD2DSM
A12C6	0160-2211		C FXD 510PF 5% 300WVDC	72136	RDM19F511J3C
A12C7	0180-0161	3	C FXD 3.3UF 20% 35WVDC	56289	150D335X0035B2-DYS
A12C8			NOT ASSIGNED		
A12C9	0180-0161		C FXD 3.3UF 20% 35WVDC	56289	150D335X0035B2-DYS
A12C10	0160-2204		C FXD 100PF 5% 300WVDC	72136	RDM15F101J3C
A12C11	0180-0161		C FXD 3.3UF 20% 35WVDC	56289	150D335X0035B2-DYS
A12C12	0160-2204		C FXD 100PF 5% 300WVDC	72136	RDM15F101J3C
A12C13	0180-0373	1	C FXD 0.68UF 10% 35WVDC	56289	150D684X9035A2-DYS
A12C14	0160-0161		C FXD 0.01UF 10% 200WVDC	56289	192P10392-PTS
A12C15	0160-0161		C FXD 0.01UF 10% 200WVDC	56289	192P10392-PTS
A12C16	0180-0089		C FXD 10UF +50-10% 150WVDC	56289	30D 106F 150DD2DSM
A12CR1	1901-0028	5	DIO SI 400PIV 750MA	04713	SR1358-9
A12CR2	1901-0028		DIO SI 400PIV 750MA	04713	SR1358-9
A12CR3	1901-0028		DIO SI 400PIV 750MA	04713	SR1358-9
A12CR4	1901-0028		DIO SI 400PIV 750MA	04713	SR1358-9
A12CR5	1901-0040		DIO SI	12065	SG5050
A12CR6	1901-0040		DIO SI	12065	SG5050

Abbreviations are listed in the introduction to this section

Table 3-1 Replaceable Parts (continued)

Ref Desig	HP Part No	TQ	Description	Mfr	Mfr Part No
A12CR7	1901-0040		DIO SI	12065	SG5050
A12CR8	1901-0159	20	DIO SI 400PIV 750MA	04713	SR1358-4
A12CR9	1901-0159		DIO SI 400PIV 750MA	04713	SR1358-4
A12CR10	1901-0159		DIO SI 400PIV 750MA	04713	SR1358-4
A12CR11	1901-0159		DIO SI 400PIV 750MA	04713	SR1358-4
A12CR12	1901-0040		DIO SI	12065	SG5050
A12CR13	1901-0040		DIO SI	12065	SG5050
A12CR14	1902-3122	2	DIO BKDN 6.65V 2% 400MW	07910	CD35656
A12CR15	1901-0159		DIO SI 400PIV 750MA	04713	SR1358-4
A12CR16	1901-0159		DIO SI 400PIV 750MA	04713	SR1358-4
A12CR17	1901-0159		DIO SI 400PIV 750MA	04713	SR1358-4
A12CR18	1901-0159		DIO SI 400PIV 750MA	04713	SR1358-4
A12CR19			NOT ASSIGNED		
A12CR20			NOT ASSIGNED		
A12CR21			NOT ASSIGNED		
A12CR22			NOT ASSIGNED		
A12CR23	1901-0159		DIO SI 400PIV 750MA	04713	SR1358-4
A12CR24	1901-0159		DIO SI 400PIV 750MA	04713	SR1358-4
A12CR25	1901-0159		DIO SI 400PIV 750MA	04713	SR1358-4
A12CR26	1901-0159		DIO SI 400PIV 750MA	04713	SR1358-4
A12CR27	1901-0159		DIO SI 400PIV 750MA	04713	SR1358-4
A12CR28	1901-0159		DIO SI 400PIV 750MA	04713	SR1358-4
A12CR29	1901-0159		DIO SI 400PIV 750MA	04713	SR1358-4
A12CR30	1901-0159		DIO SI 400PIV 750MA	04713	SR1358-4
A12CR31	1901-0159		DIO SI 400PIV 750MA	04713	SR1358-4
A12CR32	1901-0159		DIO SI 400PIV 750MA	04713	SR1358-4
A12CR33	1901-0159		DIO SI 400PIV 750MA	04713	SR1358-4
A12CR34	1901-0159		DIO SI 400PIV 750MA	04713	SR1358-4
A12CR35	1901-0040		DIO SI	12065	SG5050
A12CR36	1902-3122		DIO BKDN 6.65V 2% 400MW	07910	CD35656
A12CR37	1901-0040		DIO SI	12065	SG5050
A12CR38	1901-0028		DIO SI 400PIV 750MA	04713	SR1358-9
A12IC1	1820-0439	4	IC VOLTAGE REGULATOR	07263	SL21385
A12IC2	1820-0439		IC VOLTAGE REGULATOR	07263	SL21385
A12IC3	1820-0439		IC VOLTAGE REGULATOR	07263	SL21385
A12IC4	1820-0439		IC VOLTAGE REGULATOR	07263	SL21385
A12Q1	1853-0240	1	XSTR SI PNP	04713	SS1139K
A12Q2			NOT ASSIGNED		
A12Q3	1854-0234	1	XSTR SI NPN	02375	T0-5
A12Q4	1853-0239	4	XSTR SI PNP	04713	MM4000
A12Q5	1854-0022	8	XSTR SI NPN	03877	ST 1657
A12Q6	1205-0033	2	HEAT DISSIPATOR XSTR	05820	NF-207
A12Q7	1854-0022		XSTR SI NPN	03877	ST 1657
A12Q8	1853-0007	4	XSTR SI PNP	04713	2N3251
A12Q9	1853-0007		XSTR SI PNP	04713	2N3251
A12Q10	1853-0007		XSTR SI PNP	04713	2N3251
A12Q11	1853-0007		XSTR SI PNP	04713	2N3251
A12Q12	1854-0022		XSTR SI NPN	03877	ST 1657
A12Q13	1853-0239		XSTR SI PNP	04713	MM4000
	1205-0033		HEAT DISSIPATOR XSTR	05820	NF-207
A12Q14	1853-0239		XSTR SI PNP	04713	MM4000
A12Q15	1853-0239		XSTR SI PNP	04713	MM4000
A12R1	0764-0047	1	R FXD 82K OHM 5% 2W	16299	C-42S

Abbreviations are listed in the introduction to this section

Table 3-1 Replaceable Parts (continued)

Ref Desig	HP Part No	TQ	Description	Mfr	Mfr Part No
A12R2	0698-3446		R FXD 383 OHM 1% 1/8W	19701	MF4CT-0
A12R3	0757-0770	2	R FXD 56.2K OHM 1% 1/4W	19701	MF52C T-0
A12R4	0698-3159		R FXD 26.1K OHM 1% 1/8W	19701	MF4CT-0
A12R5	0698-4736	1	R FXD 34.8K OHM 1% 1/4W	91637	MFF-1/8-32T-1
A12R6	0757-0316	2	R FXD 42.2 OHM 1% 1/8W	19701	MF4C T-0
A12R7	0683-0365	1	R FXD 3.6 OHM 5% 1/4W	01121	CB-36G5
A12R8	0757-0733	2	R FXD 1.1K OHM 1% 1/4W	19701	MF52CT-0
A12R9	2100-2633		R VAR 1K 10% 1/2W LIN	21030	62-224-1
A12R10	0757-0747	5	R FXD 5.11K OHM 1% 1/4W	19701	MF52CT-0
A12R11	0757-0280		R FXD 1K OHM 1% 1/8W	75042	CEAT-0
A12R12	0757-0427	1	R FXD 1.5K OHM 1% 1/8W	19701	MF4CT-0
A12R13	0811-1553	1	R FXD 0.68 OHM 5% 2W	75042	BWH
A12R14	0757-0279	7	R FXD 3.16K OHM 1% 1/8W	75042	CEAT-0
A12R15	2100-2633		R VAR 1K 10% 1/2W LIN	21030	62-224-1
A12R16	0757-0279		R FXD 3.16K OHM 1% 1/8W	75042	CEAT-0
A12R17	0757-0420		R FXD 750 OHM 1% 1/8W	19701	MF4CT-0
A12R18	2100-2574	6	R VAR 500 OHM 10% 1/2W	21030	62-223-1
A12R19	0698-0084	7	R FXD 2.15K OHM 1% 1/8W	19701	MF4CT-0
A12R20	0812-0045	1	R FXD 0.15 OHM 5% 3W	91637	CW2B-1
A12R21	0757-0438		R FXD 5.11K OHM 1% 1/8W	19701	MF4CT-0
A12R22	0757-0279		R FXD 3.16K OHM 1% 1/8W	75042	CEAT-0
A12R23	0811-2466	1	R FXD 1.2 OHM 5% 1/2W	75042	BW-20
A12R24	0757-0279		R FXD 3.16K OHM 1% 1/8W	75042	CEAT-0
A12R25	0757-0274	4	R FXD 1.21K OHM 1% 1/8W	19701	MF4CT-0
A12R26	2100-2574		R VAR 500 OHM 10% 1/2W	21030	62-223-1
A12R27	0698-3154	1	R FXD 4.22K OHM 1% 1/8W	19701	MF4CT-0
A12R28	0757-0438		R FXD 5.11K OHM 1% 1/8W	19701	MF4CT-0
A12R29	0757-0279		R FXD 3.16K OHM 1% 1/8W	75042	CEAT-0
A12R30	0683-0395	1	R FXD 3.9 OHM 5% 1/4W	01121	CB39G5
A12R31	0757-0279		R FXD 3.16K OHM 1% 1/8W	75042	CEAT-0
A12R32	0757-0274		R FXD 1.21K OHM 1% 1/8W	19701	MF4CT-0
A12R33	2100-2574		R VAR 500 OHM 10% 1/2W	21030	62-223-1
A12R34	0757-0439	5	R FXD 6.81K OHM 1% 1/8W	19701	MF4C
A12R35	0698-4731	2	R FXD 26.1K OHM 1% 1/4W	91637	MFF-1/8-32T-1
A12R36	0698-3446		R FXD 383 OHM 1% 1/8W	19701	MF4CT-0
A12R37	0698-5561	1	R FXD 6.8 OHM 5% 1/8W	01121	BB68G5
A12R38	0757-0733		R FXD 1.1K OHM 1% 1/4W	19701	MF52CT-0
A12R39	2100-2633		R VAR 1K 10% 1/2W LIN	21030	62-224-1
A12R40	0757-0747		R FXD 5.11K OHM 1% 1/4W	19701	MF52CT-0
A12R41	0757-0280		R FXD 1K OHM 1% 1/8W	75042	CEAT-0
A13			CONTROL LOGIC ASSY		
	03720-30013	1	PC BD BLANK #NSR#	E0007	
	4040-0751		EXTRACTOR PC BD ORN	14493	5040-5114
	4040-0749		EXTRACTOR PC BD BRN	14493	5040-5112
	1480-0116		PIN GROOVE #TQ 2#	73957	GP24-063X250-12
A13C1	0160-2215	2	C FXD 750PF 5% 300WVDC	72136	RDM19F751J3C
A13C2	0160-0174		C FXD 0.47UF +80-20% 25WVDC	56289	5C11B7S-CML
A13C3	0160-0174		C FXD 0.47UF +80-20% 25WVDC	56289	5C11B7S-CML
A13C4	0140-0200		C FXD 390PF 5% 300WVDC	72136	RDM15F391J3C
A13C5	0160-0174		C FXD 0.47UF +80-20% 25WVDC	56289	5C11B7S-CML
A13C6	0160-0174		C FXD 0.47UF +80-20% 25WVDC	56289	5C11B7S-CML
A13C7	0160-0174		C FXD 0.47UF +80-20% 25WVDC	56289	5C11B7S-CML
A13C8	0160-0174		C FXD 0.47UF +80-20% 25WVDC	56289	5C11B7S-CML

Abbreviations are listed in the introduction to this section

Table 3-1 Replaceable Parts (continued)

Ref Desig	HP Part No	TQ	Description	Mfr	Mfr Part No
A13C9	0180-0116		C FXD 6.8UF 10% 35WVDC	56289	150D685X9035B2-DYS
A13CR1	1901-0040		DIO SI	12065	SG5050
A13CR2	1910-0034	2	DIO GE	28106	D6670
A13CR3	1910-0034		DIO GE	28106	D6670
A13CR4	1902-3357	1	DIO BKDN 56.2V 5% 400MW	07910	CD35922
A13MC11	1820-0075		IC DUAL JK FLIP-FLOP	E0001	SN4353
A13MC12	1820-0071		IC DUAL 4-I/P NAND BUFFER GATE	E0001	SN4346
A13MC13	1820-0077		IC DUAL D-TYPE FLIP-FLOP	E0001	SN4354
A13MC14	1820-0055		IC DECADE COUNTER	E0001	SN4356
A13MC15	1820-0261		IC MONOSTABLE	E0001	SN74121N
A13MC16	1820-0328		IC QUAD 2-I/P NOR GATE	E0001	SN4467
A13MC17	1820-0075		IC DUAL JK FLIP-FLOP	E0001	SN4353
A13MC18	1820-0068		IC TRIPLE 3-I/P NAND GATE	E0001	SN4343
A13MC21	1820-0075		IC DUAL JK FLIP-FLOP	E0001	SN4353
A13MC22	1820-0069		IC DUAL 4-I/P NAND GATE	E0001	SN4344
A13MC23	1820-0374	1	IC HS DUAL 4-I/P AND GATE	01295	SN4482
A13MC24	1820-0055		IC DECADE COUNTER	E0001	SN4356
A13MC25	1820-0077		IC DUAL D-TYPE FLIP-FLOP	E0001	SN4354
A13MC26	1820-0070		IC 8-I/P NAND GATE	E0001	SN4345
A13MC27	1820-0075		IC DUAL JK FLIP-FLOP	E0001	SN4353
A13MC28	1820-0054		IC QUAD 2-I/P NAND GATE	E0001	SN4342
A13MC31	1820-0075		IC DUAL JK FLIP-FLOP	E0001	SN4353
A13MC32	1820-0054		IC QUAD 2-I/P NAND GATE	E0001	SN4342
A13MC33	1820-0055		IC DECADE COUNTER	E0001	SN4356
A13MC34	1820-0068		IC TRIPLE 3-I/P NAND GATE	E0001	SN4343
A13MC35	1820-0068		IC TRIPLE 3-I/P NAND GATE	E0001	SN4343
A13MC36	1820-0054		IC QUAD 2-I/P NAND GATE	E0001	SN4342
A13MC37	1820-0075		IC DUAL JK FLIP-FLOP	E0001	SN4353
A13MC38	1820-0328		IC QUAD 2-I/P NOR GATE	E0001	SN4467
A13MC41	1820-0075		IC DUAL JK FLIP-FLOP	E0001	SN4353
A13MC42	1820-0054		IC QUAD 2-I/P NAND GATE	E0001	SN4342
A13MC43	1820-0068		IC TRIPLE 3-I/P NAND GATE	E0001	SN4343
A13MC44	1820-0511		IC QUAD 2-I/P AND GATE	E0001	SN20572
A13MC45	1820-0069		IC DUAL 4-I/P NAND GATE	E0001	SN4344
A13MC46	1820-0511		IC QUAD 2-I/P AND GATE	E0001	SN20572
A13MC47	1820-0075		IC DUAL JK FLIP-FLOP	E0001	SN4353
A13MC48	1820-0511		IC QUAD 2-I/P AND GATE	E0001	SN20572
A13MC51	1820-0261		IC MONOSTABLE	E0001	SN74121N
A13MC52	1820-0077		IC DUAL D-TYPE FLIP-FLOP	E0001	SN4354
A13MC53	1820-0328		IC QUAD 2-I/P NOR GATE	E0001	SN4467
A13MC54	1820-0174	1	IC HEX INV	E0001	SN8199
A13MC55	1820-0054		IC QUAD 2-I/P NAND GATE	E0001	SN4342
A13MC56	1820-0054		IC QUAD 2-I/P NAND GATE	E0001	SN4342
A13MC57	1820-0075		IC DUAL JK FLIP-FLOP	E0001	SN4353
A13MC58	1820-0077		IC DUAL D-TYPE FLIP-FLOP	E0001	SN4354
A13Q1	1854-0090	1	XSTR SI NPN	04713	SM8158
A13R1	0757-0280		R FXD 1K OHM 1% 1/8W	75042	CEAT-0
A13R2	0757-0280		R FXD 1K OHM 1% 1/8W	75042	CEAT-0
A13R3	0698-3150	4	R FXD 2.37K OHM 1% 1/8W	19701	MF4CT-0
A13R4	0757-0280		R FXD 1K OHM 1% 1/8W	75042	CEAT-0
A13R5	0757-0280		R FXD 1K OHM 1% 1/8W	75042	CEAT-0
A13R6	0757-0280		R FXD 1K OHM 1% 1/8W	75042	CEAT-0
A13R7	0757-0280		R FXD 1K OHM 1% 1/8W	75042	CEAT-0
A13R8	0757-0418	8	R FXD 619 OHM 1% 1/8W	19701	MF4CT-0

Abbreviations are listed in the introduction to this section

Table 3-1 Replaceable Parts (continued)

Ref Desig	HP Part No	TQ	Description	Mfr	Mfr Part No
A13R9	0698-5490		R FXD 2K OHM 1% 1/8W	91637	CMF-1/10-32T-2
A13R10	0698-5490		R FXD 2K OHM 1% 1/8W	91637	CMF-1/10-32T-2
A13R11	0698-5490		R FXD 2K OHM 1% 1/8W	91637	CMF-1/10-32T-2
A13R12	0698-5490		R FXD 2K OHM 1% 1/8W	91637	CMF-1/10-32T-2
A13S1	3101-0973	1	SW SLIDE DPOT PC BD MTG	79727	GF126-0018A
A14			TRIANGLE WAVE GENERATOR ASSY		
	03720-30014	1	PC BD BLANK #NSR#	E0007	
	4040-0752		EXTRACTOR PC BD YEL	14493	5040-5115
	4040-0749		EXTRACTOR PC BD BRN	14493	5040-5112
	1480-0116		PIN GROOVE #TQ 2#	73957	GP24-063X250-12
A14C1	0160-2257	1	C FXD 10PF 5% 500WVDC	20846	301-000-COHO-100J
A14C2	0140-0196		C FXD 150PF 5% 300WVDC	72136	RDM15F151J3C
A14C3	0160-0174		C FXD 0.47UF +80-20% 25WVDC	56289	5C11B7S-CML
A14C4	0160-0174		C FXD 0.47UF +80-20% 25WVDC	56289	5C11B7S-CML
A14C5	0180-0116		C FXD 6.8UF 10% 35WVDC	56289	150D685X9035B2-DYS
A14C6	0180-0116		C FXD 6.8UF 10% 35WVDC	56289	150D685X9035B2-DYS
A14C7	0180-0116		C FXD 6.8UF 10% 35WVDC	56289	150D685X9035B2-DYS
A14C8	0160-2225		C FXD 2000PF 5% 300WVDC	72136	RDM19F202J3C
A14C9	0160-0174		C FXD 0.47UF +80-20% 25WVDC	56289	5C11B7S-CML
A14C10	0160-2211		C FXD 510PF 5% 300WVDC	72136	RDM19F511J3C
A14C11	0170-0066		C FXD 0.027UF 10% 200WVDC	56289	192P27392-PTS
A14C12	0160-0174		C FXD 0.47UF +80-20% 25WVDC	56289	5C11B7S-CML
A14C13	0160-2218		C FXD 1000PF 5% 300WVDC	72136	RDM19F102J3C
A14C14	0160-2225		C FXD 2000PF 5% 300WVDC	72136	RDM19F202J3C
A14C15	0160-0174		C FXD 0.47UF +80-20% 25WVDC	56289	5C11B7S-CML
A14C16	0160-2211		C FXD 510PF 5% 300WVDC	72136	RDM19F511J3C
A14C17	0160-0174		C FXD 0.47UF +80-20% 25WVDC	56289	5C11B7S-CML
A14C18	0160-2218		C FXD 1000PF 5% 300WVDC	72136	RDM19F102J3C
A14C19	0160-2225		C FXD 2000PF 5% 300WVDC	72136	RDM19F202J3C
A14C20			NOT ASSIGNED		
A14C21			NOT ASSIGNED		
A14C22	0160-0174		C FXD 0.47UF +80-20% 25WVDC	56289	5C11B7S-CML
A14C23	0160-0174		C FXD 0.47UF +80-20% 25WVDC	56289	5C11B7S-CML
A14C24	0121-0105	2	C VAR 9-35PF	20846	538-0060-9-35
A14C25	0160-2205	1	C FXD 120PF 5% 300WVDC	72136	RDM15F121J3C
A14C26	0140-0200		C FXD 390PF 5% 300WVDC	72136	RDM15F391J3C
A14C27	0160-2198		C FXD 20PF 5% 300WVDC	72136	RDM15C200J3C
A14C28	0160-0645	1	C FXD 4.7PF 5% 30WVDC	E0024	8101-025
A14CR1	1902-0509		DIO BKDN 6.2V 2% TEMP COMP	04713	SZ12250
A14CR2	1901-0040		DIO SI	12065	SG5050
A14CR3	1901-0040		DIO SI	12065	SG5050
A14CR4	1901-0040		DIO SI	12065	SG5050
A14CR5	1901-0040		DIO SI	12065	SG5050
A14CR6	1901-0040		DIO SI	12065	SG5050
A14CR7	1901-0040		DIO SI	12065	SG5050
A14CR8	1901-0040		DIO SI	12065	SG5050
A14CR9			NOT ASSIGNED		
A14CR10			NOT ASSIGNED		
A14CR11	1902-0509		DIO BKDN 6.2V 2% TEMP COMP	04713	SZ12250
A14CR12	1902-0509		DIO BKDN 6.2V 2% TEMP COMP	04713	SZ12250
A14CR13	1901-0040		DIO SI	12065	SG5050
A14CR14	1901-0040		DIO SI	12065	SG5050

Abbreviations are listed in the introduction to this section

Table 3-1 Replaceable Parts (continued)

Ref Desig	HP Part No	TQ	Description	Mfr	Mfr Part No
A14CR15	1901-0040		DIO SI	12065	SG5050
A14CR16	1901-0040		DIO SI	12065	SG5050
A14CR17	1901-0040		DIO SI	12065	SG5050
A14CR18	1901-0040		DIO SI	12065	SG5050
A14CR19	1901-0040		DIO SI	12065	SG5050
A14CR20	1901-0040		DIO SI	12065	SG5050
A14CR21	1901-0040		DIO SI	12065	SG5050
A14CR22	1901-0040		DIO SI	12065	SG5050
A14CR23	1901-0040		DIO SI	12065	SG5050
A14CR24	1901-0040		DIO SI	12065	SG5050
A14CR25	1901-0040		DIO SI	12065	SG5050
A14CR26	1901-0040		DIO SI	12065	SG5050
A14CR27	1901-0040		DIO SI	12065	SG5050
A14CR28	1901-0040		DIO SI	12065	SG5050
A14CR29	1902-3114	2	DIO BKDN 6.19V 2% 400MW	07910	CD 35647
A14CR30	1902-3114		DIO BKDN 6.19V 2% 400MW	07910	CD 35647
A14CR31	1901-0040		DIO SI	12065	SG5050
A14CR32			NOT ASSIGNED		
A14CR33			NOT ASSIGNED		
A14CR34	1901-0040		DIO SI	12065	SG5050
A14CR35	1901-0040		DIO SI	12065	SG5050
A14CR36	1901-0040		DIO SI	12065	SG5050
A14CR37	1901-0040		DIO SI	12065	SG5050
A14CR38	1901-0040		DIO SI	12065	SG5050
A14CR39	1910-0016	2	DIO GE	93332	D2361
A14CR40	1910-0016		DIO GE	93332	D2361
A14CR41	1902-0041	2	DIO BKDN 5.11V 5% 400MW	07910	CD35622
A14IC1	1820-0223	1	IC OPER AMPL	12040	SL8641
A14IC2	1820-0476		IC OPER AMPL	07263	SL21384
A14IC3	1820-0476		IC OPER AMPL	07263	SL21384
A14IC4	1820-0476		IC OPER AMPL	07263	SL21384
A14Q1	1855-0389		XSTR FET N-CHANNEL	17856	WN041
A14Q2	1855-0389		XSTR FET N-CHANNEL	17856	WN041
A14Q3	1855-0389		XSTR FET N-CHANNEL	17856	WN041
A14Q4	1855-0020		XSTR FET N-CHANNEL	21845	F1151
A14Q5	1855-0020		XSTR FET N-CHANNEL	21845	F1151
A14Q6	1855-0020		XSTR FET N-CHANNEL	21845	F1151
A14Q7	1855-0020		XSTR FET N-CHANNEL	21845	F1151
A14Q8	1854-0019		XSTR SI NPN	13715	S-6516
A14Q9	1853-0036		XSTR SI PNP	04713	#2N3906# SPS-3612
A14Q10	1854-0019		XSTR SI NPN	13715	S-6516
A14Q11	1853-0036		XSTR SI PNP	04713	#2N3906# SPS-3612
A14Q12	1854-0019		XSTR SI NPN	13715	S-6516
A14Q13	1853-0036		XSTR SI PNP	04713	#2N3906# SPS-3612
A14Q14	1854-0019		XSTR SI NPN	13715	S-6516
A14Q15	1853-0036		XSTR SI PNP	04713	#2N3906# SPS-3612
A14Q16	1854-0019		XSTR SI NPN	13715	S-6516
A14Q17	1853-0036		XSTR SI PNP	04713	#2N3906# SPS-3612
A14Q18	1854-0019		XSTR SI NPN	13715	S-6516
A14Q19	1853-0036		XSTR SI PNP	04713	#2N3906# SPS-3612
A14Q20	1854-0019		XSTR SI NPN	13715	S-6516
A14Q21	1853-0036		XSTR SI PNP	04713	#2N3906# SPS-3612
A14Q22	1853-0036		XSTR SI PNP	04713	#2N3906# SPS-3612
A14Q23	1854-0019		XSTR SI NPN	13715	S-6516

Abbreviations are listed in the introduction to this section

Table 3-1 Replaceable Parts (continued)

Ref Desig	HP Part No	TQ	Description	Mfr	Mfr Part No
A14Q24			NOT ASSIGNED		
A14Q25			NOT ASSIGNED		
A14Q26	1855-0081		XSTR FET N-CHANNEL	E0001	2N5245
A14Q27	1855-0081		XSTR FET N-CHANNEL	E0001	2N5245
A14Q28	1854-0019		XSTR SI NPN	13715	S-6516
A14Q29	1853-0034	2	XSTR SI PNP	04713	SM3197
A14Q30	1855-0389		XSTR FET N-CHANNEL	17856	WN041
A14Q31	1855-0082		XSTR FET P-CHANNEL	04713	SS3723
A14Q32	1855-0389		XSTR FET N-CHANNEL	17856	WN041
A14Q33	1855-0082		XSTR FET P-CHANNEL	04713	SS3723
A14Q34	1855-0389		XSTR FET N-CHANNEL	17856	WN041
A14Q35	1855-0082		XSTR FET P-CHANNEL	04713	SS3723
A14Q36	1855-0020		XSTR FET N-CHANNEL	21845	F1151
A14Q37	1855-0020		XSTR FET N-CHANNEL	21845	F1151
A14Q38	1855-0020		XSTR FET N-CHANNEL	21845	F1151
A14Q39	1855-0020		XSTR FET N-CHANNEL	21845	F1151
A14Q40	1855-0020		XSTR FET N-CHANNEL	21845	F1151
A14Q41	1855-0082		XSTR FET P-CHANNEL	04713	SS3723
A14Q42	1853-0036		XSTR SI PNP	04713	#2N3906# SPS-3612
A14Q43			NOT ASSIGNED		
A14Q44			NOT ASSIGNED		
A14Q45	1855-0082		XSTR FET P-CHANNEL	04713	SS3723
A14Q46	1854-0019		XSTR SI NPN	13715	S-6516
A14Q47	1853-0036		XSTR SI PNP	04713	#2N3906# SPS-3612
A14Q48	1854-0019		XSTR SI NPN	13715	S-6516
A14Q49	1853-0036		XSTR SI PNP	04713	#2N3906# SPS-3612
A14Q50	1854-0019		XSTR SI NPN	13715	S-6516
A14R1	0757-0418		R FXD 619 OHM 1% 1/8W	19701	MF4CT-0
A14R2	0757-0465		R FXD 100K OHM 1% 1/8W	19701	MF4CT-0
A14R3	0757-0465		R FXD 100K OHM 1% 1/8W	19701	MF4CT-0
A14R4	0757-0465		R FXD 100K OHM 1% 1/8W	19701	MF4CT-0
A14R5	0757-0465		R FXD 100K OHM 1% 1/8W	19701	MF4CT-0
A14R6	0757-0465		R FXD 100K OHM 1% 1/8W	19701	MF4CT-0
A14R7	0757-0465		R FXD 100K OHM 1% 1/8W	19701	MF4CT-0
A14R8	0757-0465		R FXD 100K OHM 1% 1/8W	19701	MF4CT-0
A14R9	0698-8204		R FXD 7.98K OHM 0.1% 1/8W	19701	MF4CT-9
A14R10	0698-8205		R FXD 15.98K OHM 0.1% 1/8W	19701	MF4CT-9
A14R11	0698-8047		R FXD 32K OHM 0.1% 1/8W	19701	MF4CT-9
A14R12	0698-8049		R FXD 64K OHM 0.1% 1/8W	19701	MF4CT-9
A14R13	0698-8053		R FXD 128K OHM 0.1% 1/8W	75042	CCAT-9
A14R14	0698-8050		R FXD 256K OHM 0.1% 1/8W	19701	MF4CT-9
A14R15	0698-8051		R FXD 512K OHM 0.1% 1/8W	75042	CCAT-9
A14R16			NOT ASSIGNED		
A14R17			NOT ASSIGNED		
A14R18	0757-0441	2	R FXD 8.25K OHM 1% 1/8W	19701	MF4CT-0
A14R19	0698-5490		R FXD 2K OHM 1% 1/8W	91637	CMF-1/10-32T-2
A14R20	0698-5490		R FXD 2K OHM 1% 1/8W	91637	CMF-1/10-32T-2
A14R21	0698-3446		R FXD 383 OHM 1% 1/8W	19701	MF4CT-0
A14R22	0698-3153		R FXD 3.83K OHM 1% 1/8W	19701	MF4CT-0
A14R23	0757-0444	19	R FXD 12.1K OHM 1% 1/8W	19701	MF4CT-0
A14R24	0698-5490		R FXD 2K OHM 1% 1/8W	91637	CMF-1/10-32T-2
A14R25	0698-5490		R FXD 2K OHM 1% 1/8W	91637	CMF-1/10-32T-2
A14R26	0698-3446		R FXD 383 OHM 1% 1/8W	19701	MF4CT-0
A14R27	0698-3153		R FXD 3.83K OHM 1% 1/8W	19701	MF4CT-0
A14R28	0757-0444		R FXD 12.1K OHM 1% 1/8W	19701	MF4CT-0

Abbreviations are listed in the introduction to this section

Table 3-1 Replaceable Parts (continued)

Ref Desig	HP Part No	TQ	Description	Mfr	Mfr Part No
A14R29	0698-5490		R FXD 2K OHM 1% 1/8W	91637	CMF-1/10-32T-2
A14R30	0698-5490		R FXD 2K OHM 1% 1/8W	91637	CMF-1/10-32T-2
A14R31	0698-3446		R FXD 383 OHM 1% 1/8W	19701	MF4CT-0
A14R32	0698-3153		R FXD 3.83K OHM 1% 1/8W	19701	MF4CT-0
A14R33	0757-0444		R FXD 12.1K OHM 1% 1/8W	19701	MF4CT-0
A14R34	0698-5490		R FXD 2K OHM 1% 1/8W	91637	CMF-1/10-32T-2
A14R35	0698-5490		R FXD 2K OHM 1% 1/8W	91637	CMF-1/10-32T-2
A14R36	0698-3446		R FXD 383 OHM 1% 1/8W	19701	MF4CT-0
A14R37	0698-3153		R FXD 3.83K OHM 1% 1/8W	19701	MF4CT-0
A14R38	0757-0444		R FXD 12.1K OHM 1% 1/8W	19701	MF4CT-0
A14R39	0698-5490		R FXD 2K OHM 1% 1/8W	91637	CMF-1/10-32T-2
A14R40	0698-5490		R FXD 2K OHM 1% 1/8W	91637	CMF-1/10-32T-2
A14R41	0698-3446		R FXD 383 OHM 1% 1/8W	19701	MF4CT-0
A14R42	0698-3153		R FXD 3.83K OHM 1% 1/8W	19701	MF4CT-0
A14R43	0757-0444		R FXD 12.1K OHM 1% 1/8W	19701	MF4CT-0
A14R44	0698-5490		R FXD 2K OHM 1% 1/8W	91637	CMF-1/10-32T-2
A14R45	0698-5490		R FXD 2K OHM 1% 1/8W	91637	CMF-1/10-32T-2
A14R46	0698-3446		R FXD 383 OHM 1% 1/8W	19701	MF4CT-0
A14R47	0698-3153		R FXD 3.83K OHM 1% 1/8W	19701	MF4CT-0
A14R48	0757-0444		R FXD 12.1K OHM 1% 1/8W	19701	MF4CT-0
A14R49	0698-5490		R FXD 2K OHM 1% 1/8W	91637	CMF-1/10-32T-2
A14R50	0698-5490		R FXD 2K OHM 1% 1/8W	91637	CMF-1/10-32T-2
A14R51	0698-3446		R FXD 383 OHM 1% 1/8W	19701	MF4CT-0
A14R52	0698-3153		R FXD 3.83K OHM 1% 1/8W	19701	MF4CT-0
A14R53	0757-0444		R FXD 12.1K OHM 1% 1/8W	19701	MF4CT-0
A14R54	0757-0416		R FXD 511 OHM 1% 1/8W	19701	MF4CT-0
A14R55	0757-0290		R FXD 6.19K OHM 1% 1/8W	75042	CEA
A14R56	0757-0418		R FXD 619 OHM 1% 1/8W	19701	MF4CT-0
A14R57	0757-0316		R FXD 42.2 OHM 1% 1/8W	19701	MF4C T-0
A14R58	0757-0734	1	R FXD 1.21K OHM 1% 1/4W	19701	MF52C T-0
A14R59			NOT ASSIGNED		
A14R60			NOT ASSIGNED		
A14R61	0698-3446		R FXD 383 OHM 1% 1/8W	19701	MF4CT-0
A14R62			NOT ASSIGNED		
A14R63	2100-2632	3	R VAR 100 OHM 10% 1/2W	21030	62-221-1
A14R64			NOT ASSIGNED		
A14R65	2100-2574		R VAR 500 OHM 10% 1/2W	21030	62-223-1
A14R66	0698-0085		R FXD 2.61K OHM 1% 1/8W	19701	MF4CT-0
A14R67	0757-0465		R FXD 100K OHM 1% 1/8W	19701	MF4CT-0
A14R68	0698-5490		R FXD 2K OHM 1% 1/8W	91637	CMF-1/10-32T-2
A14R69	0757-0465		R FXD 100K OHM 1% 1/8W	19701	MF4CT-0
A14R70	0757-0446	4	R FXD 15K OHM 1% 1/8W	19701	MF4C
A14R71	2100-2515	1	R VAR 200K OHM 10% 1/2W	21030	62-232-1
A14R72	0698-3459	1	R FXD 383K OHM 1% 1/8W	01295	
A14R73	0757-0402	1	R FXD 110 OHM 1% 1/8W	19701	MF4CT-0
A14R74	0698-0085		R FXD 2.61K OHM 1% 1/8W	19701	MF4CT-0
A14R75	0698-3440	1	R FXD 196 OHM 1% 1/8W	19701	MF4C T-0
A14R76	2100-2521		R VAR 2K OHM 10% 1/2W LIN	73138	62-225-1
A14R77	0757-0200	5	R FXD 5.62K OHM 1% 1/8W	19701	MF4C
A14R78	0698-0085		R FXD 2.61K OHM 1% 1/8W	19701	MF4CT-0
A14R79	0757-0440	1	R FXD 7.5K OHM 1% 1/8W	19701	MF4CT-0
A14R80	0757-0442		R FXD 10K OHM 1% 1/8W	19701	MF4C
A14R81	0757-0442		R FXD 10K OHM 1% 1/8W	19701	MF4C
A14R82	0757-0416		R FXD 511 OHM 1% 1/8W	19701	MF4CT-0
A14R83	0683-0475	4	R FXD 4.7 OHM 5% 1/4W	01121	CB47G5

Abbreviations are listed in the introduction to this section

Table 3-1 Replaceable Parts (continued)

Ref Desig	HP Part No	TQ	Description	Mfr	Mfr Part No
A14R84	0683-0475		R FXD 4.7 OHM 5% 1/4W	01121	CB47G5
A14R85	0757-0416		R FXD 511 OHM 1% 1/8W	19701	MF4CT-0
A14R86	0757-0465		R FXD 100K OHM 1% 1/8W	19701	MF4CT-0
A14R87	0757-0465		R FXD 100K OHM 1% 1/8W	19701	MF4CT-0
A14R88	0757-0465		R FXD 100K OHM 1% 1/8W	19701	MF4CT-0
A14R89	0757-0465		R FXD 100K OHM 1% 1/8W	19701	MF4CT-0
A14R90	0757-0465		R FXD 100K OHM 1% 1/8W	19701	MF4CT-0
A14R91	0757-0465		R FXD 100K OHM 1% 1/8W	19701	MF4CT-0
A14R92	0757-0465		R FXD 100K OHM 1% 1/8W	19701	MF4CT-0
A14R93	0757-0458		R FXD 51.1K OHM 1% 1/8W	19701	MF4CT-0
A14R94	0757-0465		R FXD 100K OHM 1% 1/8W	19701	MF4CT-0
A14R95	0757-0458		R FXD 51.1K OHM 1% 1/8W	19701	MF4CT-0
A14R96	0757-0465		R FXD 100K OHM 1% 1/8W	19701	MF4CT-0
A14R97	0757-0458		R FXD 51.1K OHM 1% 1/8W	19701	MF4CT-0
A14R98	0757-0465		R FXD 100K OHM 1% 1/8W	19701	MF4CT-0
A14R99	0757-0458		R FXD 51.1K OHM 1% 1/8W	19701	MF4CT-0
A14R100	0698-8204		R FXD 7.98K OHM 0.1% 1/8W	19701	MF4CT-9
A14R101	0698-8205		R FXD 15.98K OHM 0.1% 1/8W	19701	MF4CT-9
A14R102	0698-8047		R FXD 32K OHM 0.1% 1/8W	19701	MF4CT-9
A14R103	0698-8049		R FXD 64K OHM 0.1% 1/8W	19701	MF4CT-9
A14R104	0698-8053		R FXD 128K OHM 0.1% 1/8W	75042	CCAT-9
A14R105	0698-8050		R FXD 256K OHM 0.1% 1/8W	19701	MF4CT-9
A14R106	0698-8051		R FXD 512K OHM 0.1% 1/8W	75042	CCAT-9
A14R107			NOT ASSIGNED		
A14R108			NOT ASSIGNED		
A14R109	0757-0465		R FXD 100K OHM 1% 1/8W	19701	MF4CT-0
A14R110	0757-0384	2	R FXD 20 OHM 1% 1/8W	19701	MF4C
A14R111	2100-2670	1	R VAR 20 OHM +30-0% LIN	21030	62-236-1
A14R112	0757-0384		R FXD 20 OHM 1% 1/8W	19701	MF4C
A14R113	0698-3162		R FXD 46.4K OHM 1% 1/8W	19701	MF4CT-0
A14R114	0698-3132	1	R FXD 261 OHM 1% 1/8W	19701	MF4CT-0
A14R115	0757-0441		R FXD 8.25K OHM 1% 1/8W	19701	MF4CT-0
A14R116	2100-2633		R VAR 1K 10% 1/2W LIN	21030	62-224-1
A14R117	0698-3155		R FXD 4.64K OHM 1% 1/8W	19701	MF4CT-0
A14R118			NOT ASSIGNED		
A14R119			NOT ASSIGNED		
A14R120	0757-0465		R FXD 100K OHM 1% 1/8W	19701	MF4CT-0
A14R121	0698-3155		R FXD 4.64K OHM 1% 1/8W	19701	MF4CT-0
A14R122	0757-0280		R FXD 1K OHM 1% 1/8W	75042	CEAT-0
A14R123	0757-0200		R FXD 5.62K OHM 1% 1/8W	19701	MF4C
A14R124	0757-0439		R FXD 6.81K OHM 1% 1/8W	19701	MF4C
A14R125	0757-0290		R FXD 6.19K OHM 1% 1/8W	75042	CEA
A14R126	0757-0418		R FXD 619 OHM 1% 1/8W	19701	MF4CT-0
A14R127	0698-3446		R FXD 383 OHM 1% 1/8W	19701	MF4CT-0
A14R128	0698-3153		R FXD 3.83K OHM 1% 1/8W	19701	MF4CT-0
A14R129	0698-5490		R FXD 2K OHM 1% 1/8W	91637	CMF-1/10-32T-2
A14R130	0698-5490		R FXD 2K OHM 1% 1/8W	91637	CMF-1/10-32T-2
A14R131	0757-0750		R FXD 6.81K OHM 1% 1/4W	19701	MF52CT-0
A14R132	0698-3446		R FXD 383 OHM 1% 1/8W	19701	MF4CT-0
A14R133	0698-3153		R FXD 3.83K OHM 1% 1/8W	19701	MF4CT-0
A14R134	0698-5490		R FXD 2K OHM 1% 1/8W	91637	CMF-1/10-32T-2
A14R135	0698-5490		R FXD 2K OHM 1% 1/8W	91637	CMF-1/10-32T-2
A14R136	0757-0280		R FXD 1K OHM 1% 1/8W	75042	CEAT-0
A14R137	0757-0280		R FXD 1K OHM 1% 1/8W	75042	CEAT-0

Abbreviations are listed in the introduction to this section

Table 3-1 Replaceable Parts (continued)

Ref Desig	HP Part No	TQ	Description	Mfr	Mfr Part No
A15			SINE SHAPER ASSY		
	03720-30015	1	PC BD BLANK #NSR#	E0007	
	4040-0753		EXTRACTOR PC BD GRN	14493	5040-5116
	4040-0749		EXTRACTOR PC BD BRN	14493	5040-5112
	1480-0116		PIN GROOVE #TQ 2#	73957	GP24-063X250-12
A15C1	0160-0174		C FXD 0.47UF +80-20% 25WVDC	56289	5C11B7S-CML
A15C2	0160-0174		C FXD 0.47UF +80-20% 25WVDC	56289	5C11B7S-CML
A15C3	0160-2199		C FXD 30PF 5% 300WVDC	72136	RDM15E300J3C
A15C4	0160-0174		C FXD 0.47UF +80-20% 25WVDC	56289	5C11B7S-CML
A15C5	0160-0174		C FXD 0.47UF +80-20% 25WVDC	56289	5C11B7S-CML
A15C6	0160-2199		C FXD 30PF 5% 300WVDC	72136	RDM15E300J3C
A15C7	0160-0174		C FXD 0.47UF +80-20% 25WVDC	56289	5C11B7S-CML
A15C8	0160-0174		C FXD 0.47UF +80-20% 25WVDC	56289	5C11B7S-CML
A15C9	0180-0116		C FXD 6.8UF 10% 35WVDC	56289	150D685X9035B2-DYS
A15C10	0180-0116		C FXD 6.8UF 10% 35WVDC	56289	150D685X9035B2-DYS
A15C11	0160-2211		C FXD 510PF 5% 300WVDC	72136	RDM19F511J3C
A15C12	0160-2218		C FXD 1000PF 5% 300WVDC	72136	RDM19F102J3C
A15C13	0160-2225		C FXD 2000PF 5% 300WVDC	72136	RDM19F202J3C
A15C14	0150-0059	2	C FXD 3.3PF 0.25PF 500WVDC	72982	301-000-CUJO-339C
A15C15	0180-0116		C FXD 6.8UF 10% 35WVDC	56289	150D685X9035B2-DYS
A15C16	0180-0116		C FXD 6.8UF 10% 35WVDC	56289	150D685X9035B2-DYS
A15C17	0150-0059		C FXD 3.3PF 0.25PF 500WVDC	72982	301-000-CUJO-339C
A15C18	0160-2243	1	C FXD 2.7PF 0.25PF 500WVDC	20846	301-000-COJO 279C
A15C19	0121-0105		C VAR 9-35PF	20846	538-006D-9-35
A15C20	0160-2215		C FXD 750PF 5% 300WVDC	72136	RDM19F751J3C
A15C21	0140-0197		C FXD 180PF 5% 300WVDC	72136	RDM15F181J3C
A15C22	0160-0174		C FXD 0.47UF +80-20% 25WVDC	56289	5C11B7S-CML
A15C23	0160-0174		C FXD 0.47UF +80-20% 25WVDC	56289	5C11B7S-CML
A15C24	0180-0116		C FXD 6.8UF 10% 35WVDC	56289	150D685X9035B2-DYS
A15C25	0180-0116		C FXD 6.8UF 10% 35WVDC	56289	150D685X9035B2-DYS
A15C26	0180-0116		C FXD 6.8UF 10% 35WVDC	56289	150D685X9035B2-DYS
A15C27	0180-0116		C FXD 6.8UF 10% 35WVDC	56289	150D685X9035B2-DYS
A15C28	0160-2241	2	C FXD 2.2PF 0.25PF 500WVDC	72982	301-000-CUJO-2290
A15C29	0160-2239	1	C FXD 1.8PF 0.25PF 500WVDC	20846	301-000-COKO 189C
A15C30	0160-2241		C FXD 2.2PF 0.25PF 500WVDC	72982	301-000-CUJO-2290
A15C31	0160-2247	2	C FXD 3.9PF 0.25PF 500WVDC	72982	301-000-CUJO-399C
A15C32	0160-2247		C FXD 3.9PF 0.25PF 500WVDC	72982	301-000-CUJO-399C
A15C33	0160-2251	1	C FXD 5.6PF 0.25PF 500WVDC	20846	301-000-COHO-569G
A15CR1	1902-0041		DIO BKDN 5.11V 5% 400MW	07910	CD35622
A15CR2	1901-0040		DIO SI	12065	SG5050
A15CR3	1901-0040		DIO SI	12065	SG5050
A15CR4	1901-0040		DIO SI	12065	SG5050
A15CR5	1901-0040		DIO SI	12065	SG5050
A15CR6	1901-0040		DIO SI	12065	SG5050
A15CR7	1901-0040		DIO SI	12065	SG5050
A15CR8	1901-0040		DIO SI	12065	SG5050
A15CR9	1901-0040		DIO SI	12065	SG5050
A15CR10	1901-0040		DIO SI	12065	SG5050
A15CR11	1901-0040		DIO SI	12065	SG5050
A15CR12	1901-0040		DIO SI	12065	SG5050
A15CR13	1901-0040		DIO SI	12065	SG5050
A15CR14	1901-0040		DIO SI	12065	SG5050
A15CR15	1901-0040		DIO SI	12065	SG5050
A15CR16	1901-0040		DIO SI	12065	SG5050

Abbreviations are listed in the introduction to this section

Table 3-1 Replaceable Parts (continued)

Ref Desig	HP Part No	TQ	Description	Mfr	Mfr Part No
A15CR17	1902-3070	1	DIO BKDN 4.22V 5% 400MW	07910	CD35598
A15CP18	1901-0040		DIO SI	12065	SG5050
A15CR19	1901-0040		DIO SI	12065	SG5050
A15CR20	1901-0040		DIO SI	12065	SG5050
A15CR21	1901-0040		DIO SI	12065	SG5050
A15CR22	1901-0040		DIO SI	12065	SG5050
A15CR23	1901-0040		DIO SI	12065	SG5050
A15CR24	1901-0040		DIO SI	12065	SG5050
A15CR25	1901-0040		DIO SI	12065	SG5050
A15CR26	1901-0040		DIO SI	12065	SG5050
A15CR27	1901-0040		DIO SI	12065	SG5050
A15CR28	1901-0040		DIO SI	12065	SG5050
A15CR29	1901-0040		DIO SI	12065	SG5050
A15CR30	1901-0040		DIO SI	12065	SG5050
A15CR31	1901-0040		DIO SI	12065	SG5050
A15CR32	1901-0040		DIO SI	12065	SG5050
A15CR33	1901-0040		DIO SI	12065	SG5050
A15CR34	1901-0040		DIO SI	12065	SG5050
A15IC1	1820-0477		IC OPER AMPL	01295	SN19Z31
A15IC2	1820-0477		IC OPER AMPL	01295	SN19Z31
A15IC3	1820-0476		IC OPER AMPL	07263	SL21384
A15IC4	1826-0021		IC VOLTAGE FOLLOWER	12040	SL11611
A15Q1	1854-0019		XSTR SI NPN	13715	S-6516
A15Q2	1854-0019		XSTR SI NPN	13715	S-6516
A15Q3	1854-0019		XSTR SI NPN	13715	S-6516
A15Q4	1853-0034		XSTR SI PNP	04713	UM3197
A15Q5	1855-0338	1	XSTR FET N-CHANNEL	E0016	UCS2200/1
A15Q6	1854-0019		XSTR SI NPN	13715	S-6516
A15Q7	1853-0036		XSTR SI PNP	04713	#2N3906# SPS-3612
A15Q8	1854-0019		XSTR SI NPN	13715	S-6516
A15Q9	1853-0036		XSTR SI PNP	04713	#2N3906# SPS-3612
A15Q10	1854-0215		XSTR SI NPN	04713	SPS3611
A15Q11	1855-0020		XSTR FET N-CHANNEL	21845	F1151
A15Q12	1855-0020		XSTR FET N-CHANNEL	21845	F1151
A15Q13	1855-0020		XSTR FET N-CHANNEL	21845	F1151
A15Q14	1855-0020		XSTR FET N-CHANNEL	21845	F1151
A15Q15	1854-0019		XSTR SI NPN	13715	S-6516
A15Q16	1853-0036		XSTR SI PNP	04713	#2N3906# SPS-3612
A15Q17	1854-0215		XSTR SI NPN	04713	SPS3611
A15Q18	1855-0020		XSTR FET N-CHANNEL	21845	F1151
A15Q19	1855-0020		XSTR FET N-CHANNEL	21845	F1151
A15Q20	1855-0020		XSTR FET N-CHANNEL	21845	F1151
A15Q21	1855-0020		XSTR FET N-CHANNEL	21845	F1151
A15Q22	1854-0019		XSTR SI NPN	13715	S-6516
A15Q23	1853-0036		XSTR SI PNP	04713	#2N3906# SPS-3612
A15Q24	1854-0215		XSTR SI NPN	04713	SPS3611
A15Q25	1855-0020		XSTR FET N-CHANNEL	21845	F1151
A15Q26	1855-0020		XSTR FET N-CHANNEL	21845	F1151
A15Q27	1855-0020		XSTR FET N-CHANNEL	21845	F1151
A15Q28	1855-0020		XSTR FET N-CHANNEL	21845	F1151
A15Q29	1854-0019		XSTR SI NPN	13715	S-6516
A15Q30	1853-0036		XSTR SI PNP	04713	#2N3906# SPS-3612
A15Q31	1854-0215		XSTR SI NPN	04713	SPS3611
A15Q32	1855-0020		XSTR FET N-CHANNEL	21845	F1151
A15Q33	1855-0020		XSTR FET N-CHANNEL	21845	F1151

Abbreviations are listed in the introduction to this section

Table 3-1 Replaceable Parts (continued)

Ref Desig	HP Part No	TQ	Description	Mfr	Mfr Part No
A15Q34	1855-0020		XSTR FET N-CHANNEL	21845	F1151
A15Q35	1855-0020		XSTR FET N-CHANNEL	21845	F1151
A15R1	0757-0416		R FXD 511 OHM 1% 1/8W	19701	MF4CT-0
A15R2	2100-2574		R VAR 500 OHM 10% 1/2W	21030	62-223-1
A15R3	0698-5490		R FXD 2K OHM 1% 1/8W	91637	CMF-1/10-32T-2
A15R4	0698-5490		R FXD 2K OHM 1% 1/8W	91637	CMF-1/10-32T-2
A15R5	0757-0338	2	R FXD 1K OHM 1% 1/4W	19701	MF52CT-0
A15R6	0683-3905	2	R FXD 39 OHM 5% 1/4W	01121	CB3905
A15R7	0683-3005	2	R FXD 30 OHM 5% 1/4W	01121	CB3005
A15R8	0683-4705	2	R FXD 47 OHM 5% 1/4W	01121	CB4705
A15R9	0683-8205	2	R FXD 82 OHM 5% 1/4W	01121	CB8205
A15R10	0683-3305	2	R FXD 33 OHM 5% 1/4W	01121	CB3305
A15R11	0683-1015	2	R FXD 100 OHM 5% 1/4W	01121	CB1015
A15R12	0683-1215	1	R FXD 120 OHM 5% 1/4W	01121	CB1215
A15R13	0683-3315	1	R FXD 330 OHM 5% 1/4W	01121	CB3315
A15R14	0683-4715	1	R FXD 470 OHM 5% 1/4W	01121	CB4715
A15R15	0683-1025	1	R FXD 1K OHM 5% 1/4W	01121	CB1025
A15R16	0683-2025	1	R FXD 2K OHM 5% 1/4W	01121	CB2025
A15R17	0683-3905		R FXD 39 OHM 5% 1/4W	01121	CB3905
A15R18	0683-3005		R FXD 30 OHM 5% 1/4W	01121	CB3005
A15R19	0683-4705		R FXD 47 OHM 5% 1/4W	01121	CB4705
A15R20	0683-8205		R FXD 82 OHM 5% 1/4W	01121	CB8205
A15R21	0683-3305		R FXD 33 OHM 5% 1/4W	01121	CB3305
A15R22	0683-1015		R FXD 100 OHM 5% 1/4W	01121	CB1015
A15R23	0757-0338		R FXD 1K OHM 1% 1/4W	19701	MF52CT-0
A15R24	0757-0280		R FXD 1K OHM 1% 1/8W	75042	CEAT-0
A15R25	0698-5490		R FXD 2K OHM 1% 1/8W	91637	CMF-1/10-32T-2
A15R26	2100-2574		R VAR 500 OHM 10% 1/2W	21030	62-223-1
A15R27	0757-0407	2	R FXD 200 OHM 1% 1/8W	19701	MF4C
A15R28	2100-2633		R VAR 1K 10% 1/2W LIN	21030	62-224-1
A15R29	0698-6361	1	R FXD 8K OHM 0.1% 1/8W	75042	CEAT-9
A15R30	0698-0082	4	R FXD 464 OHM 1% 1/8W	19701	MF4CT-0
A15R31	0698-0082		R FXD 464 OHM 1% 1/8W	19701	MF4CT-0
A15R32	0698-3274	3	R FXD 10K OHM 1% 1/8W	19701	MF4CT-9
A15R33	0757-0442		R FXD 10K OHM 1% 1/8W	19701	MF4C
A15R34	0757-0442		R FXD 10K OHM 1% 1/8W	19701	MF4C
A15R35	0698-0082		R FXD 464 OHM 1% 1/8W	19701	MF4CT-0
A15R36	0683-0475		R FXD 4.7 OHM 5% 1/4W	01121	CB47G5
A15R37	0683-0475		R FXD 4.7 OHM 5% 1/4W	01121	CB47G5
A15R38	0698-0082		R FXD 464 OHM 1% 1/8W	19701	MF4CT-0
A15R39	0757-0458		R FXD 51.1K OHM 1% 1/8W	19701	MF4CT-0
A15R40	0757-0747		R FXD 5.11K OHM 1% 1/4W	19701	MF52CT-0
A15R41	0698-3153		R FXD 3.83K OHM 1% 1/8W	19701	MF4CT-0
A15R42	0698-3446		R FXD 383 OHM 1% 1/8W	19701	MF4CT-0
A15R43	0698-3153		R FXD 4.64K OHM 1% 1/8W	19701	MF4CT-0
A15R44			NOT ASSIGNED		
A15R45	0757-0458		R FXD 51.1K OHM 1% 1/8W	19701	MF4CT-0
A15R46	0698-5490		R FXD 2K OHM 1% 1/8W	91637	CMF-1/10-32T-2
A15R47	0698-5490		R FXD 2K OHM 1% 1/8W	91637	CMF-1/10-32T-2
A15R48	0698-3446		R FXD 383 OHM 1% 1/8W	19701	MF4CT-0
A15R49	0698-3153		R FXD 3.83K OHM 1% 1/8W	19701	MF4CT-0
A15R50	0757-0444		R FXD 12.1K OHM 1% 1/8W	19701	MF4CT-0
A15R51	0757-0418		R FXD 619 OHM 1% 1/8W	19701	MF4CT-0
A15R52	0757-0444		R FXD 12.1K OHM 1% 1/8W	19701	MF4CT-0
A15R53	0757-0465		R FXD 100K OHM 1% 1/8W	19701	MF4CT-0

Abbreviations are listed in the introduction to this section

Table 3-1 Replaceable Parts (continued)

Ref Desig	HP Part No	TQ	Description	Mfr	Mfr Part No
A15R54	0757-0465		R FXD 100K OHM 1% 1/8W	19701	MF4CT-0
A15R55	0698-8049		R FXD 64K OHM 0.1% 1/8W	19701	MF4CT-9
A15R56	0698-8049		R FXD 64K OHM 0.1% 1/8W	19701	MF4CT-9
A15R57	0757-0465		R FXD 100K OHM 1% 1/8W	19701	MF4CT-0
A15R58	0757-0465		R FXD 100K OHM 1% 1/8W	19701	MF4CT-0
A15R59	0698-8049		R FXD 64K OHM 0.1% 1/8W	19701	MF4CT-9
A15R60	0698-8049		R FXD 64K OHM 0.1% 1/8W	19701	MF4CT-9
A15R61	0698-5490		R FXD 2K OHM 1% 1/8W	91637	CMF-1/10-32T-2
A15R62	0698-5490		R FXD 2K OHM 1% 1/8W	91637	CMF-1/10-32T-2
A15R63	0698-3446		R FXD 383 OHM 1% 1/8W	19701	MF4CT-0
A15R64	0698-3153		R FXD 3.83K OHM 1% 1/8W	19701	MF4CT-0
A15R65	0757-0444		R FXD 12.1K OHM 1% 1/8W	19701	MF4CT-0
A15R66	0757-0418		R FXD 619 OHM 1% 1/8W	19701	MF4CT-0
A15R67	0757-0444		R FXD 12.1K OHM 1% 1/8W	19701	MF4CT-0
A15R68	0757-0465		R FXD 100K OHM 1% 1/8W	19701	MF4CT-0
A15R69	0757-0465		R FXD 100K OHM 1% 1/8W	19701	MF4CT-0
A15R70	0698-8049		R FXD 64K OHM 0.1% 1/8W	19701	MF4CT-9
A15R71	0698-8047		R FXD 32K OHM 0.1% 1/8W	19701	MF4CT-9
A15R72	0757-0465		R FXD 100K OHM 1% 1/8W	19701	MF4CT-0
A15R73	0757-0465		R FXD 100K OHM 1% 1/8W	19701	MF4CT-0
A15R74	0698-8049		R FXD 64K OHM 0.1% 1/8W	19701	MF4CT-9
A15R75	0698-8047		R FXD 32K OHM 0.1% 1/8W	19701	MF4CT-9
A15R76	0698-5490		R FXD 2K OHM 1% 1/8W	91637	CMF-1/10-32T-2
A15R77	0698-5490		R FXD 2K OHM 1% 1/8W	91637	CMF-1/10-32T-2
A15R78	0698-3446		R FXD 383 OHM 1% 1/8W	19701	MF4CT-0
A15R79	0698-3153		R FXD 3.83K OHM 1% 1/8W	19701	MF4CT-0
A15R80	0757-0444		R FXD 12.1K OHM 1% 1/8W	19701	MF4CT-0
A15R81	0757-0418		R FXD 619 OHM 1% 1/8W	19701	MF4CT-0
A15R82	0757-0444		R FXD 12.1K OHM 1% 1/8W	19701	MF4CT-0
A15R83	0757-0465		R FXD 100K OHM 1% 1/8W	19701	MF4CT-0
A15R84	0757-0465		R FXD 100K OHM 1% 1/8W	19701	MF4CT-0
A15R85	0698-8049		R FXD 64K OHM 0.1% 1/8W	19701	MF4CT-9
A15R86	0698-8047		R FXD 32K OHM 0.1% 1/8W	19701	MF4CT-9
A15R87	0757-0465		R FXD 100K OHM 1% 1/8W	19701	MF4CT-0
A15R88	0757-0465		R FXD 100K OHM 1% 1/8W	19701	MF4CT-0
A15R89	0698-8049		R FXD 64K OHM 0.1% 1/8W	19701	MF4CT-9
A15R90	0698-8047		R FXD 32K OHM 0.1% 1/8W	19701	MF4CT-9
A15R91	0698-5490		R FXD 2K OHM 1% 1/8W	91637	CMF-1/10-32T-2
A15R92	0698-5490		R FXD 2K OHM 1% 1/8W	91637	CMF-1/10-32T-2
A15R93	0698-3446		R FXD 383 OHM 1% 1/8W	19701	MF4CT-0
A15R94	0698-3153		R FXD 3.83K OHM 1% 1/8W	19701	MF4CT-0
A15R95	0757-0444		R FXD 12.1K OHM 1% 1/8W	19701	MF4CT-0
A15R96	0757-0418		R FXD 619 OHM 1% 1/8W	19701	MF4CT-0
A15R97	0757-0444		R FXD 12.1K OHM 1% 1/8W	19701	MF4CT-0
A15R98	0757-0465		R FXD 100K OHM 1% 1/8W	19701	MF4CT-0
A15R99	0757-0465		R FXD 100K OHM 1% 1/8W	19701	MF4CT-0
A15R100	0698-8049		R FXD 64K OHM 0.1% 1/8W	19701	MF4CT-9
A15R101	0698-8047		R FXD 32K OHM 0.1% 1/8W	19701	MF4CT-9
A15R102	0757-0465		R FXD 100K OHM 1% 1/8W	19701	MF4CT-0
A15R103	0757-0465		R FXD 100K OHM 1% 1/8W	19701	MF4CT-0
A15R104	0698-8049		R FXD 64K OHM 0.1% 1/8W	19701	MF4CT-9
A15R105	0698-8047		R FXD 32K OHM 0.1% 1/8W	19701	MF4CT-9
A15R106	0698-8051		R FXD 512K OHM 0.1% 1/8W	75042	CCAT-9
A15R107	0698-8179	2	R FXD 288K OHM 0.1% 1/8W	19701	MENGT-9
A15R108	0698-8051		R FXD 512K OHM 0.1% 1/8W	75042	CCAT-9

Abbreviations are listed in the introduction to this section

Table 3-1 Replaceable Parts (continued)

Ref Desig	HP Part No	TQ	Description	Mfr	Mfr Part No
A15R109	0698-8051		R FXD 512K OHM 0.1% 1/8W	75042	CCAT-9
A15R110	0698-8179		R FXD 288K OHM 0.1% 1/8W	19701	MENGT-9
A15R111	0757-0401		R FXD 100 OHM 1% 1/8W	19701	MF4CT-0
A15R112	0757-0438		R FXD 5.11K OHM 1% 1/8W	19701	MF4CT-0
A16			DEFLECTION AMPLIFIERS ASSY		
	03720-30016	1	PC BD BLANK #NSR#	E0007	
	4040-0754		EXTRACTOR PC BD BLU	14493	5040-5117
	4040-0749		EXTRACTOR PC BD BRN	14493	5040-5112
	1480-0116		PIN GROOVE #TQ 2#	73957	GP24-063X250-12
A16C1	0160-2199		C FXD 30PF 5% 300WVDC	72136	RDM15E300J3C
A16C2	0160-0127	2	C FXD 1UF 20% 25WVDC	56289	5C13CS-CML
A16C3	0160-2199		C FXD 30PF 5% 300WVDC	72136	RDM15E300J3C
A16C4	0160-0128	2	C FXD 2.2UF 20% 25WVDC	56289	5C15C2-CML
A16C5	0160-2199		C FXD 30PF 5% 300WVDC	72136	RDM15E300J3C
A16C6	0160-0127		C FXD 1UF 20% 25WVDC	56289	5C13CS-CML
A16C7	0160-2199		C FXD 30PF 5% 300WVDC	72136	RDM15E300J3C
A16C8	0160-0128		C FXD 2.2UF 20% 25WVDC	56289	5C15C2-CML
A16C9	0160-2204		C FXD 100PF 5% 300WVDC	72136	RDM15F101J3C
A16C10	0160-2199		C FXD 30PF 5% 300WVDC	72136	RDM15E300J3C
A16C11	0160-2204		C FXD 100PF 5% 300WVDC	72136	RDM15F101J3C
A16C12	0160-2199		C FXD 30PF 5% 300WVDC	72136	RDM15E300J3C
A16C13	0160-2199		C FXD 30PF 5% 300WVDC	72136	RDM15E300J3C
A16C14	0160-2204		C FXD 100PF 5% 300WVDC	72136	RDM15F101J3C
A16C15	0160-2199		C FXD 30PF 5% 300WVDC	72136	RDM15E300J3C
A16C16	0160-2204		C FXD 100PF 5% 300WVDC	72136	RDM15F101J3C
A16C17	0160-2199		C FXD 30PF 5% 300WVDC	72136	RDM15E300J3C
A16C18	0160-2199		C FXD 30PF 5% 300WVDC	72136	RDM15E300J3C
A16C19	0160-0174		C FXD 0.47UF +80-20% 25WVDC	56289	5C11B7S-CML
A16C20	0160-0174		C FXD 0.47UF +80-20% 25WVDC	56289	5C11B7S-CML
A16C21	0160-0174		C FXD 0.47UF +80-20% 25WVDC	56289	5C11B7S-CML
A16C22	0160-0174		C FXD 0.47UF +80-20% 25WVDC	56289	5C11B7S-CML
A16C23	0160-0174		C FXD 0.47UF +80-20% 25WVDC	56289	5C11B7S-CML
A16C24	0160-0174		C FXD 0.47UF +80-20% 25WVDC	56289	5C11B7S-CML
A16C25			NUT ASSIGNED		
A16C26	0160-2201	1	C FXD 51PF 5% 300WVDC	72136	RDM15E510J3C
A16CR1	1901-0040		DIO SI	12065	SG5050
A16CR2	1901-0040		DIO SI	12065	SG5050
A16CR3	1901-0040		DIO SI	12065	SG5050
A16CR4	1901-0040		DIO SI	12065	SG5050
A16CR5	1901-0040		DIO SI	12065	SG5050
A16CR6	1902-0049	2	DIO BKDN 6.19V 400MW	07910	CD35646
A16CR7	1901-0040		DIO SI	12065	SG5050
A16CR8	1901-0040		DIO SI	12065	SG5050
A16CR9	1901-0040		DIO SI	12065	SG5050
A16CR10	1901-0040		DIO SI	12065	SG5050
A16CR11	1901-0040		DIO SI	12065	SG5050
A16CR12	1901-0040		DIO SI	12065	SG5050
A16CR13	1901-0040		DIO SI	12065	SG5050
A16CR14	1902-0049		DIO BKDN 6.19V 400MW	07910	CD35646
A16CR15	1901-0040		DIO SI	12065	SG5050
A16CR16	1902-0509		DIO BKDN 6.2V 2% TEMP COMP	04713	SZ12250
A16CR17	1902-0509		DIO BKDN 6.2V 2% TEMP COMP	04713	SZ12250

Abbreviations are listed in the introduction to this section

Table 3-1 Replaceable Parts (continued)

Ref Desig	HP Part No	TQ	Description	Mfr	Mfr Part No
A16CR18	1902-0509		DIO BKDN 6.2V 2% TEMP COMP	04713	SZ12250
A16CR19	1902-3059		DIO BKDN 3.83V 5% 400MW	07910	CD 35586
A16CR20	1902-0596	1	DIO BKDN 9V 5% 500MW	04713	SZ11736
A16IC1	1820-0477		IC OPER AMPL	01295	SN19Z31
A16IC2	1820-0477		IC OPER AMPL	01295	SN19Z31
A16IC3	1820-0477		IC OPER AMPL	01295	SN19Z31
A16IC4	1820-0477		IC OPER AMPL	01295	SN19Z31
A16IC5	1820-0477		IC OPER AMPL	01295	SN19Z31
A16IC6	1820-0477		IC OPER AMPL	01295	SN19Z31
A16IC7	1820-0477		IC OPER AMPL	01295	SN19Z31
A16IC8	1820-0477		IC OPER AMPL	01295	SN19Z31
A16IC9	1820-0477		IC OPER AMPL	01295	SN19Z31
A16IC10	1820-0477		IC OPER AMPL	01295	SN19Z31
A16IC11	1820-0477		IC OPER AMPL	01295	SN19Z31
A16Q1	1854-0019		XSTR SI NPN	13715	S-6516
A16Q2	1853-0036		XSTR SI PNP	04713	#2N3906# SPS-3612
A16Q3	1854-0019		XSTR SI NPN	13715	S-6516
A16Q4	1853-0036		XSTR SI PNP	04713	#2N3906# SPS-3612
A16Q5	1854-0019		XSTR SI NPN	13715	S-6516
A16Q6	1853-0036		XSTR SI PNP	04713	#2N3906# SPS-3612
A16Q7	1855-0020		XSTR FET N-CHANNEL	21845	F1151
A16Q8	1855-0020		XSTR FET N-CHANNEL	21845	F1151
A16Q9	1855-0020		XSTR FET N-CHANNEL	21845	F1151
A16Q10	1854-0232	4	XSTR SI NPN	03508	
A16Q11	1854-0071	11	XSTR SI NPN	01295	SKA1124
A16Q12	1854-0232		XSTR SI NPN	03508	
A16Q13	1855-0020		XSTR FET N-CHANNEL	21845	F1151
A16Q14	1854-0019		XSTR SI NPN	13715	S-6516
A16Q15	1853-0036		XSTR SI PNP	04713	#2N3906# SPS-3612
A16Q16	1854-0019		XSTR SI NPN	13715	S-6516
A16Q17	1853-0036		XSTR SI PNP	04713	#2N3906# SPS-3612
A16Q18	1854-0019		XSTR SI NPN	13715	S-6516
A16Q19	1853-0036		XSTR SI PNP	04713	#2N3906# SPS-3612
A16Q20	1855-0020		XSTR FET N-CHANNEL	21845	F1151
A16Q21	1855-0020		XSTR FET N-CHANNEL	21845	F1151
A16Q22	1855-0020		XSTR FET N-CHANNEL	21845	F1151
A16Q23	1854-0019		XSTR SI NPN	13715	S-6516
A16Q24	1853-0036		XSTR SI PNP	04713	#2N3906# SPS-3612
A16Q25	1854-0232		XSTR SI NPN	03508	
A16Q26	1854-0071		XSTR SI NPN	01295	SKA1124
A16Q27	1854-0232		XSTR SI NPN	03508	
A16Q28	1855-0020		XSTR FET N-CHANNEL	21845	F1151
A16Q29	1826-0031	2	XSTR DUAL TEMP CONT	07263	SL22133
A16Q30	1826-0031		XSTR DUAL TEMP CONT	07263	SL22133
A16R1	0698-5490		R FXD 2K OHM 1% 1/8W	91637	CMF-1/10-32T-2
A16R2	0698-5490		R FXD 2K OHM 1% 1/8W	91637	CMF-1/10-32T-2
A16R3	0698-3446		R FXD 383 OHM 1% 1/8W	19701	MF4CT-0
A16R4	0698-3153		R FXD 3.83K OHM 1% 1/8W	19701	MF4CT-0
A16R5	0757-0750		R FXD 6.81K OHM 1% 1/4W	19701	MF52CT-0
A16R6	0698-5490		R FXD 2K OHM 1% 1/8W	91637	CMF-1/10-32T-2
A16R7	0698-5490		R FXD 2K OHM 1% 1/8W	91637	CMF-1/10-32T-2
A16R8	0698-3446		R FXD 383 OHM 1% 1/8W	19701	MF4CT-0
A16R9	0698-3153		R FXD 3.83K OHM 1% 1/8W	19701	MF4CT-0
A16R10	0757-0750		R FXD 6.81K OHM 1% 1/4W	19701	MF52CT-0
A16R11	0757-0442		R FXD 10K OHM 1% 1/8W	19701	MF4C

Abbreviations are listed in the introduction to this section

Table 3-1 Replaceable Parts (continued)

Ref Desig	HP Part No	TQ	Description	Mfr	Mfr Part No
A16R12	0698-3446		R FXD 383 OHM 1% 1/8W	19701	MF4CT-0
A16R13	0698-3153		R FXD 3.83K OHM 1% 1/8W	19701	MF4CT-0
A16R14	0757-0750		R FXD 6.81K OHM 1% 1/4W	19701	MF52CT-0
A16R15	0757-0465		R FXD 100K OHM 1% 1/8W	19701	MF4CT-0
A16R16	0698-5542		R FXD 20K OHM 1% 1/8W	91637	CMF-1/10-32T-9
A16R17	0698-5542		R FXD 20K OHM 1% 1/8W	91637	CMF-1/10-32T-9
A16R18	0757-0438		R FXD 5.11K OHM 1% 1/8W	19701	MF4CT-0
A16R19	0698-3499	2	R FXD 40.2K OHM 1% 1/8W	75042	CEAT-0
A16R20	0757-0465		R FXD 100K OHM 1% 1/8W	19701	MF4CT-0
A16R21	0698-3136		R FXD 17.8K 1% 1/8W	19701	MF4CT-0
A16R22	0757-0465		R FXD 100K OHM 1% 1/8W	19701	MF4CT-0
A16R23	0698-3274		R FXD 10K OHM 1% 1/8W	19701	MF4CT-9
A16R24	0698-5490		R FXD 2K OHM 1% 1/8W	91637	CMF-1/10-32T-2
A16R25	0698-5490		R FXD 2K OHM 1% 1/8W	91637	CMF-1/10-32T-2
A16R26	0757-0771	4	R FXD 61.9K OHM 1% 1/4W	19701	MF52CT-0
A16R27	0698-0084		R FXD 2.15K OHM 1% 1/8W	19701	MF4CT-0
A16R28	0757-0444		R FXD 12.1K OHM 1% 1/8W	19701	MF4CT-0
A16R29	0698-4438	2	R FXD 3.09K OHM 1% 1/8W	75042	CEA T-0
A16R30	0757-0771		R FXD 61.9K OHM 1% 1/4W	19701	MF52CT-0
A16R31	0698-0084		R FXD 2.15K OHM 1% 1/8W	19701	MF4CT-0
A16R32	0698-0085		R FXD 2.61K OHM 1% 1/8W	19701	MF4CT-0
A16R33	0698-5490		R FXD 2K OHM 1% 1/8W	91637	CMF-1/10-32T-2
A16R34	0757-0438		R FXD 5.11K OHM 1% 1/8W	19701	MF4CT-0
A16R35	0757-0439		R FXD 6.81K OHM 1% 1/8W	19701	MF4C
A16R36	0698-6360		R FXD 10K OHM 0.1% 1/8W	75042	CEAT-9
A16R37	0698-6360		R FXD 10K OHM 0.1% 1/8W	75042	CEAT-9
A16R38	0698-3159		R FXD 26.1K OHM 1% 1/8W	19701	MF4CT-0
A16R39	0757-0465		R FXD 100K OHM 1% 1/8W	19701	MF4CT-0
A16R40	0698-3159		R FXD 26.1K OHM 1% 1/8W	19701	MF4CT-0
A16R41			NOT ASSIGNED		
A16R42			NOT ASSIGNED		
A16R43	0698-5490		R FXD 2K OHM 1% 1/8W	91637	CMF-1/10-32T-2
A16R44	0698-5490		R FXD 2K OHM 1% 1/8W	91637	CMF-1/10-32T-2
A16R45	0698-3446		R FXD 383 OHM 1% 1/8W	19701	MF4CT-0
A16R46	0698-3153		R FXD 3.83K OHM 1% 1/8W	19701	MF4CT-0
A16R47	0757-0750		R FXD 6.81K OHM 1% 1/4W	19701	MF52CT-0
A16R48	0698-5490		R FXD 2K OHM 1% 1/8W	91637	CMF-1/10-32T-2
A16R49	0698-5490		R FXD 2K OHM 1% 1/8W	91637	CMF-1/10-32T-2
A16R50	0698-3446		R FXD 383 OHM 1% 1/8W	19701	MF4CT-0
A16R51	0698-3153		R FXD 3.83K OHM 1% 1/8W	19701	MF4CT-0
A16R52	0757-0750		R FXD 6.81K OHM 1% 1/4W	19701	MF52CT-0
A16R53	0757-0442		R FXD 10K OHM 1% 1/8W	19701	MF4C
A16R54	0698-3446		R FXD 383 OHM 1% 1/8W	19701	MF4CT-0
A16R55	0698-3153		R FXD 3.83K OHM 1% 1/8W	19701	MF4CT-0
A16R56	0757-0750		R FXD 6.81K OHM 1% 1/4W	19701	MF52CT-0
A16R57	0757-0465		R FXD 100K OHM 1% 1/8W	19701	MF4CT-0
A16R58	0698-5542		R FXD 20K OHM 1% 1/8W	91637	CMF-1/10-32T-9
A16R59	0698-5542		R FXD 20K OHM 1% 1/8W	91637	CMF-1/10-32T-9
A16R60	0757-0438		R FXD 5.11K OHM 1% 1/8W	19701	MF4CT-0
A16R61	0698-3499		R FXD 40.2K OHM 1% 1/8W	75042	CEAT-0
A16R62	0757-0465		R FXD 100K OHM 1% 1/8W	19701	MF4CT-0
A16R63	0698-3136		R FXD 17.8K 1% 1/8W	19701	MF4CT-0
A16R64	0757-0465		R FXD 100K OHM 1% 1/8W	19701	MF4CT-0
A16R65	0698-3274		R FXD 10K OHM 1% 1/8W	19701	MF4CT-9
A16R66	0698-5490		R FXD 2K OHM 1% 1/8W	91637	CMF-1/10-32T-2

Abbreviations are listed in the introduction to this section

Table 3-1 Replaceable Parts (continued)

Ref Desig	HP Part No	TQ	Description	Mfr	Mfr Part No
A16R67	0698-5490		R FXD 2K OHM 1% 1/8W	91637	CMF-1/10-32T-2
A16R68	0698-3446		R FXD 383 OHM 1% 1/8W	19701	MF4CT-0
A16R69	0698-3153		R FXD 3.83K OHM 1% 1/8W	19701	MF4CT-0
A16R70	0757-0750		R FXD 6.81K OHM 1% 1/4W	19701	MF52CT-0
A16R71	0698-5490		R FXD 2K OHM 1% 1/8W	91637	CMF-1/10-32T-2
A16R72	0698-5490		R FXD 2K OHM 1% 1/8W	91637	CMF-1/10-32T-2
A16R73	0757-0771		R FXD 61.9K OHM 1% 1/4W	19701	MF52CT-0
A16R74	0698-0084		R FXD 2.15K OHM 1% 1/8W	19701	MF4CT-0
A16R75	0757-0444		R FXD 12.1K OHM 1% 1/8W	19701	MF4CT-0
A16R76	0698-4438		R FXD 3.09K OHM 1% 1/8W	75042	CEA T-0
A16R77	0757-0771		R FXD 61.9K OHM 1% 1/4W	19701	MF52CT-0
A16R78	0698-0084		R FXD 2.15K OHM 1% 1/8W	19701	MF4CT-0
A16R79	0698-0085		R FXD 2.61K OHM 1% 1/8W	19701	MF4CT-0
A16R80	0698-5490		R FXD 2K OHM 1% 1/8W	91637	CMF-1/10-32T-2
A16R81	0757-0438		R FXD 5.11K OHM 1% 1/8W	19701	MF4CT-0
A16R82	0757-0439		R FXD 6.81K OHM 1% 1/8W	19701	MF4C
A16R83	0698-6360		R FXD 10K OHM 0.1% 1/8W	75042	CEAT-9
A16R84	0698-6360		R FXD 10K OHM 0.1% 1/8W	75042	CEAT-9
A16R85	0698-3159		R FXD 26.1K OHM 1% 1/8W	19701	MF4CT-0
A16R86	0757-0465		R FXD 100K OHM 1% 1/8W	19701	MF4CT-0
A16R87	0698-3159		R FXD 26.1K OHM 1% 1/8W	19701	MF4CT-0
A16R88			NOT ASSIGNED		
A16R89			NOT ASSIGNED		
A16R90	0698-3161	9	R FXD 38.3K OHM 1% 1/8W	19701	MF4CT-0
A16R91	0698-3153		R FXD 3.83K OHM 1% 1/8W	19701	MF4CT-0
A16R92	2100-2521		R VAR 2K OHM 10% 1/2W LIN	73138	62-225-1
A16R93	0698-3155		R FXD 4.64K OHM 1% 1/8W	19701	MF4CT-0
A16R94	0757-0482		R FXD 511K OHM 1% 1/8W	19701	MF5C T-0
A16R95	0698-3161		R FXD 38.3K OHM 1% 1/8W	19701	MF4CT-0
A16R96	0757-0467	3	R FXD 121K OHM 1% 1/8W	19701	MF4CT-0
A16R97	0757-0401		R FXD 100 OHM 1% 1/8W	19701	MF4CT-0
A16R98	0698-3155		R FXD 4.64K OHM 1% 1/8W	19701	MF4CT-0
A16R99	0757-0444		R FXD 12.1K OHM 1% 1/8W	19701	MF4CT-0
A16R100	0757-0398	1	R FXD 75 OHM 1% 1/8W	19701	MF4C
A16R101	2100-2632		R VAR 100 OHM 10% 1/2W	21030	62-221-1
A16R102	0698-3161		R FXD 38.3K OHM 1% 1/8W	19701	MF4CT-0
A16R103	0698-3161		R FXD 38.3K OHM 1% 1/8W	19701	MF4CT-0
A16R104	0757-0438		R FXD 5.11K OHM 1% 1/8W	19701	MF4CT-0
A16R105	2100-2521		R VAR 2K OHM 10% 1/2W LIN	73138	62-225-1
A16R106	0757-0416		R FXD 511 OHM 1% 1/8W	19701	MF4CT-0
A16R107	0757-0280		R FXD 1K OHM 1% 1/8W	75042	CEAT-0
A16R108	0757-0280		R FXD 1K OHM 1% 1/8W	75042	CEAT-0
A16R109	0757-0280		R FXD 1K OHM 1% 1/8W	75042	CEAT-0
A16R110	0698-6360		R FXD 10K OHM 0.1% 1/8W	75042	CEAT-9
A16R111	0698-8205		R FXD 15.98K OHM 0.1% 1/8W	19701	MF4CT-9
A16R112	0757-0290		R FXD 6.19K OHM 1% 1/8W	75042	CEA
A16R113	0698-5542		R FXD 20K OHM 1% 1/8W	91637	CMF-1/10-32T-9
A16R114	0698-3161		R FXD 38.3K OHM 1% 1/8W	19701	MF4CT-0
A16R115	0698-3153		R FXD 3.83K OHM 1% 1/8W	19701	MF4CT-0
A16R116	2100-2521		R VAR 2K OHM 10% 1/2W LIN	73138	62-225-1
A16R117	0698-3155		R FXD 4.64K OHM 1% 1/8W	19701	MF4CT-0
A16R118	0757-0482		R FXD 511K OHM 1% 1/8W	19701	MF5C T-0
A16R119	0698-3161		R FXD 38.3K OHM 1% 1/8W	19701	MF4CT-0
A16R120	0757-0467		R FXD 121K OHM 1% 1/8W	19701	MF4CT-0
A16R121	0757-0401		R FXD 100 OHM 1% 1/8W	19701	MF4CT-0

Abbreviations are listed in the introduction to this section

Table 3-1 Replaceable Parts (continued)

Ref Desig	HP Part No	TQ	Description	Mfr	Mfr Part No
A16R122	0757-1094	1	R FXD 1.47K OHM 1% 1/8W	19701	MF4CT--0
A16R123	0757-0444		R FXD 12.1K OHM 1% 1/8W	19701	MF4CT-0
A16R124	0757-0407		R FXD 200 OHM 1% 1/8W	19701	MF4C
A16R125	2100-2632		R VAR 100 OHM 10% 1/2W	21030	62-221-1
A16R126	0757-0442		R FXD 10K OHM 1% 1/8W	19701	MF4C
A16R127	0757-0442		R FXD 10K OHM 1% 1/8W	19701	MF4C
A16R128	0757-0442		R FXD 10K OHM 1% 1/8W	19701	MF4C
A16R129	0698-3161		R FXD 38.3K OHM 1% 1/8W	19701	MF4CT-0
A16R130	0698-3161		R FXD 38.3K OHM 1% 1/8W	19701	MF4CT-0
A16R131	0757-0438		R FXD 5.11K OHM 1% 1/8W	19701	MF4CT-0
A16R132	2100-2521		R VAR 2K OHM 10% 1/2W LIN	73138	62-225-1
A16R133	0757-0416		R FXD 511 OHM 1% 1/8W	19701	MF4CT-0
A16R134	0757-0274		R FXD 1.21K OHM 1% 1/8W	19701	MF4CT-0
A16R135	0757-0289	4	R FXD 13.3K OHM 1% 1/8W	75042	CEAT-0
A16R136	0698-3200	1	R FXD 8K OHM 1% 1/8W	19701	MF4C T-0
A16R137	0757-0420		R FXD 750 OHM 1% 1/8W	19701	MF4CT-0
A16R138	0757-0416		R FXD 511 OHM 1% 1/8W	19701	MF4CT-0
A16R139	2100-2061	1	R VAR 200 OHM 10% 1/2W	21030	
A17			HIGH VOLTAGE POWER SUPPLY ASSY		
	03720-30017	1	PC BD BLANK #NSR#	E0007	
A17C1	0180-0116		C FXD 6.8UF 10% 35WVDC	56289	150D685X9035B2-DYS
A17C2	0180-0228	2	C FXD 22UF 10% 15WVDC	56289	150D226X9015B2-DYS
A17C3	0160-0151	11	C FXD 4700PF +80-20% 4000WVDC	71590	2DDH67S472ZAA
A17C4	0160-0151		C FXD 4700PF +80-20% 4000WVDC	71590	2DDH67S472ZAA
A17C5	0160-0151		C FXD 4700PF +80-20% 4000WVDC	71590	2DDH67S472ZAA
A17C6	0160-0151		C FXD 4700PF +80-20% 4000WVDC	71590	2DDH67S472ZAA
A17C7	0160-0151		C FXD 4700PF +80-20% 4000WVDC	71590	2DDH67S472ZAA
A17C8	0160-0151		C FXD 4700PF +80-20% 4000WVDC	71590	2DDH67S472ZAA
A17C9	0160-0151		C FXD 4700PF +80-20% 4000WVDC	71590	2DDH67S472ZAA
A17C10	0160-0151		C FXD 4700PF +80-20% 4000WVDC	71590	2DDH67S472ZAA
A17C11	0160-0151		C FXD 4700PF +80-20% 4000WVDC	71590	2DDH67S472ZAA
A17C12	0160-0151		C FXD 4700PF +80-20% 4000WVDC	71590	2DDH67S472ZAA
A17C13	0160-0151		C FXD 4700PF +80-20% 4000WVDC	71590	2DDH67S472ZAA
A17C14	0180-0089		C FXD 10UF +50-10% 150WVDC	56289	30D 106F 150DD2DSM
A17C15	0160-0165	2	C FXD 0.056UF 10% 200WVDC	56289	
A17C16	0160-0162	1	C FXD 0.022UF 10% 200WVDC	56289	
A17C17	0160-2403	1	C FXD 1500PF 20% 5000WVDC	20846	828-025-X5R0-152M
A17C18	0160-0165		C FXD 0.056UF 10% 200WVDC	56289	
A17CR1	1901-0050	2	DIO SI	07263	FD6195
A17CR2	1901-0050		DIO SI	07263	FD6195
A17CR3	1901-0341	2	DIO SI 7500PIV 10MA	16352	COD12356
A17CR4	1901-0045	1	DIO SI 100PIV 750MA	04713	SR1358-7
A17CR5	1901-0341		DIO SI 7500PIV 10MA	16352	COD12356
A17CR6	1901-0040		DIO SI	12065	SG5050
A17CR7	1901-0026	7	DIO SI	04713	SR1358-8
A17CR8	1901-0040		DIO SI	12065	SG5050
A17CR9	1901-0040		DIO SI	12065	SG5050
A17L1	9140-0118	1	IND FXD 500UH 5%	99800	2500-14
A17L2	9100-1622	1	IND FXD 24UH 5%	99800	1537-46
A17MP1	03721-10030	1	SUPPORT HIGH VOLTAGE ASSY	E0007	
A17MP2	5040-0402	1	MOUNT XFMR	E0007	
A17MP3	5040-0430	1	MOUNT XFMR	E0007	
A17Q1	1854-0019		XSTR SI NPN	13715	S-6516

Abbreviations are listed in the introduction to this section

Table 3-1 Replaceable Parts (continued)

Ref Desig	HP Part No	TQ	Description	Mfr	Mfr Part No
A17Q2	1854-0039	4	XSTR SI NPN	02735	2N3053
A17Q3	1854-0039		XSTR SI NPN	02735	2N3053
A17Q4	1854-0039		XSTR SI NPN	02735	2N3053
A17Q5	1854-0039		XSTR SI NPN	02735	2N3053
A17Q6	1854-0330		XSTR SI NPN	04713	SJE901
	03721-10036	1	HEAT DISSIPATOR XSTR	E0007	
A17Q7	1853-0036		XSTR SI PNP	04713	#2N3906# SPS-3612
A17Q8	1855-0057	1	XSTR FET N-CHANNEL	04713	SS-3651
A17R1	0698-3150		R FXD 2.37K OHM 1% 1/8W	19701	MF4CT-0
A17R2	0698-3150		R FXD 2.37K OHM 1% 1/8W	19701	MF4CT-0
A17R3	0757-0424		R FXD 1.1K OHM 1% 1/8W	19701	MF4CT-0
A17R4	0757-0200		R FXD 5.62K OHM 1% 1/8W	19701	MF4C
A17R5	0757-0747		R FXD 5.11K OHM 1% 1/4W	19701	MF52CT-0
A17R6	0757-0401		R FXD 100 OHM 1% 1/8W	19701	MF4CT-0
A17R7	0757-0438		R FXD 5.11K OHM 1% 1/8W	19701	MF4CT-0
A17R8	0698-3159		R FXD 26.1K OHM 1% 1/8W	19701	MF4CT-0
A17R9	0757-0199	4	R FXD 21.5K OHM 1% 1/8W	19701	MF4CT-0
A17R1C	0698-3161		R FXD 38.3K OHM 1% 1/8W	19701	MF4CT-0
A17R11	0757-0200		R FXD 5.62K OHM 1% 1/8W	19701	MF4C
A17R12	0757-0200		R FXD 5.62K OHM 1% 1/8W	19701	MF4C
A17R13	0698-3444	2	R FXD 316 OHM 1% 1/8W	19701	MF4CT-0
A17R14	0698-3432	1	R FXD 26.1 OHM 1% 1/8W	19701	MF4CT-0
A17R15	0698-4729	1	R FXD 23.7K OHM 1% 1/4W	91637	MFF-1/8-32T-1
A17R16	0698-4731		R FXD 26.1K OHM 1% 1/4W	91637	MFF-1/8-32T-1
A17R17	0698-4037	2	R FXD 46.4 OHM 1% 1/8W	75042	CEAT-0
A17R18	0757-0199		R FXD 21.5K OHM 1% 1/8W	19701	MF4CT-0
A17R19	2100-1969	1	R VAR 1M OHM 20% 3/4W	E0007	
A17R20	0836-0003	2	R FXD 29M OHM 10% 1W	77764	BBFW
A17R21	0683-1055	1	R FXD 1M OHM 5% 1/4W	01121	CB 1055
A17R22	0698-0084		R FXD 2.15K OHM 1% 1/8W	19701	MF4CT-0
A17R23	0757-0446		R FXD 15K OHM 1% 1/8W	19701	MF4C
A17R24	0698-3441	1	R FXD 215 OHM 1% 1/8W	19701	MF4CT-0
A17R25	0757-0284		R FXD 150 OHM 1% 1/8W	75042	CEAT-0
A17R26	0757-0438		R FXD 5.11K OHM 1% 1/8W	19701	MF4CT-0
A17R27	0757-0465		R FXD 100K OHM 1% 1/8W	19701	MF4CT-0
A17R28	0757-0467		R FXD 121K OHM 1% 1/8W	19701	MF4CT-0
A17R29	0757-0482		R FXD 511K OHM 1% 1/8W	19701	MF5C T-0
A17R30	2100-2516		R VAR 100K OHM 1% 1/2W	21030	
A17R31	0698-6239	1	R FXD 30M OHM 2% 1W	03888	HV2000N5
A17R32	0686-3955	1	R FXD 3.9M OHM 5% 1/2W	01121	EB3955
A17R33	0836-0003		R FXD 29M OHM 10% 1W	77764	BBFW
A17T1	01201-61102	1	XFMR HIGH VOLTAGE	E0007	
A17V1	2140-0013	2	VOLTAGE REGULATOR NEON	08806	SAB-A#NE-23A#
A17V2	2140-0013		VOLTAGE REGULATOR NEON	08806	SAB-A#NE-23A#
A18			RANGE INDICATOR ASSY		
	03720-30018	1	PC BD BLANK #NSR#	E0007	
A18DS1	5082-5622	5	DISPLAY LED	E0007	
A18DS2	5082-5622		DISPLAY LED	E0007	
A18DS3	5082-5622		DISPLAY LED	E0007	
A18DS4	5082-5622		DISPLAY LED	E0007	
A18DS5	5082-5622		DISPLAY LED	E0007	
A18MP1	1200-0432	1	SOCKET IC #TQ 40#	27264	1938-4

Abbreviations are listed in the introduction to this section

Table 3-1 Replaceable Parts (continued)

Ref Desig	HP Part No	TQ	Description	Mfr	Mfr Part No
A19			RANGE UNITS ASSY		
	03720-30019	1	PC BD BLANK #NSR#	E0007	
A19DS1	2140-0301	10	LAMP INCD 14V 80MA	E0007	
A19DS1	2140-0301		LAMP INCD 14V 80MA	E0007	
A19DS3	2140-0301		LAMP INCD 14V 80MA	E0007	
A19DS4	2140-0301		LAMP INCD 14V 80MA	E0007	
A19DS5	2140-0301		LAMP INCD 14V 80MA	E0007	
A19DS6	2140-0301		LAMP INCD 14V 80MA	E0007	
A19DS7	2140-0301		LAMP INCD 14V 80MA	E0007	
A19DS8	2140-0301		LAMP INCD 14V 80MA	E0007	
A19DS9	2140-0301		LAMP INCD 14V 80MA	E0007	
A19DS10	2140-0301		LAMP INCD 14V 80MA	E0007	
A19R1	0698-7626	3	R FXD 38.3 OHM 1% 1/4W	19701	MF52CT-0
A19R2	0698-7626		R FXD 38.3 OHM 1% 1/4W	19701	MF52CT-0
A19R3	0698-7626		R FXD 38.3 OHM 1% 1/4W	19701	MF52CT-0
A20			STORAGE ASSY		
	03720-30020	1	PC BD BLANK #NSR#	E0007	
A20C1					
A20C2					
A20C3	0160-2229	1	C FXD 3000PF 5% 300WVDC	72136	RDM19F302J3C
A20C4	0160-2210	1	C FXD 470PF 5% 300WVDC	72136	RDM19F471J3C
A20C5	0160-2220	1	C FXD 1200PF 5% 300WVDC	72136	0BD
A20C6	0180-1795	1	C FXD 22UF 20% 70WVDC	56289	130D226X0070F2-DYP
A20C7	0180-1834	1	C FXD 15UF 20% 50WVDC	56289	150D156X0050R2-DYS
A20C8	0160-0168	1	C FXD 0.1UF 10% 200WVDC	56289	192P10492-PTS
A20C9	0180-0100	1	C FXD 4.7UF 10% 35WVDC	56289	150D475X9035B2-DYS
A20C10	0150-0050	1	C FXD 1000PF +80-20% 1000WVDC	91418	
A20C11	0160-2146	3	C FXD 0.02UF +80-20% 100WVDC	91418	TA
A20C12	0150-0121	1	C FXD 0.1UF +80-20% 50WVDC	56289	5C50B1S-CML
A20C13	0150-0093		C FXD 0.01UF +80-10% 100WVDC	91418	
A20C14	0180-0291	1	C FXD 1UF +10% 35WVDC	56289	150D105X9035A2-DYS
A20C15	0180-0058	1	C FXD 50UF +75-10% 25WVDC	56289	30D506G025CC2-D5M
A20C16	0180-0228		C FXD 22UF 10% 15WVDC	56289	150D226X9015B2-DYS
A20C17	0180-1746		C FXD 15UF 10% 20WVDC	56289	150D156X9020B2-DYS
A20C18	0160-2897	2	C FXD 0.02UF +80-20% 600WVDC	71590	DD 0D203
A20C19	0160-2897		C FXD 0.02UF +80-20% 600WVDC	71590	DD 0D203
A20C20	0160-2146		C FXD 0.02UF +80-20% 100WVDC	91418	TA
A20C21	0160-2146		C FXD 0.02UF +80-20% 100WVDC	91418	TA
A20CR1	1901-0025	16	DIO SI	12065	SG-817
A20CR2	1901-0025		DIO SI	12065	SG-817
A20CR3	1901-0026		DIO SI	04713	SR1358-8
A20CR4	1901-0025		DIO SI	12065	SG-817
A20CR5	1902-3203	1	DIO BKDN 14.7V 5% 400MW	07910	CD35754
A20CR6	1901-0026		DIO SI	04713	SR1358-8
A20CR7	1901-0026		DIO SI	04713	SR1358-8
A20CR8	1901-0025		DIO SI	12065	SG-817
A20CR9	1901-0026		DIO SI	04713	SR1358-8
A20CR10	1901-0026		DIO SI	04713	SR1358-8
A20CR11	1901-0025		DIO SI	12065	SG-817
A20CR12	1901-0418	1	DIO SI 400PIV 3A	04713	SR1846-12
A20CR13	1901-0026		DIO SI	04713	SR1358-8

Abbreviations are listed in the introduction to this section

Table 3-1 Replaceable Parts (continued)

Ref Desig	HP Part No	TQ	Description	Mfr	Mfr Part No
A20CR14	1901-0025		DIO SI	12065	SG-817
A20CR15	1901-0025		DIO SI	12065	SG-817
A20CR16	1901-0025		DIO SI	12065	SG-817
A20CR17	1901-0025		DIO SI	12065	SG-817
A20CR18	1902-3224	1	DIO BKDN 17.8V 5% 400MW	04713	
A20CR19	1884-0074	1	SI CONT REC 30V 800MA	04713	2N060 0
A20CR20	1901-0025		DIO SI	12065	SG-817
A20CR21	1901-0025		DIO SI	12065	SG-817
A20CR22	1901-0025		DIO SI	12065	SG-817
A20CR23	1901-0025		DIO SI	12065	SG-817
A20CR24	1901-0025		DIO SI	12065	SG-817
A20CR25	1902-3323	1	DIO BKDN 42.2V 5% 400MW	07910	CD35886
A20CR26	1901-0025		DIO SI	12065	SG-817
A20CR27	1901-0025		DIO SI	12065	SG-817
A20F1	2110-0001	1	FUSE 1A 250V	75915	312001
	2110-0269	1	FUSE CLIP #TQ 2#	91506	6008-32CN
A20Q1	1853-0020	4	XSTR SI PNP	E0001	SKA1123
A20Q2	1854-0071		XSTR SI NPN	01295	SKA1124
A20Q3	1853-0020		XSTR SI PNP	E0001	SKA1123
A20Q4	1853-0020		XSTR SI PNP	E0001	SKA1123
A20Q5	1855-0317	1	XSTR SI UNIJUNCTION	E0007	
A20Q6	1854-0071		XSTR SI NPN	01295	SKA1124
A20Q7	1854-0071		XSTR SI NPN	01295	SKA1124
A20Q8	1854-0254	1	XSTR SI NPN	04713	SS2065
A20Q9	1854-0022		XSTR SI NPN	03877	ST 1657
A20Q10	1853-0020		XSTR SI PNP	E0001	SKA1123
A20Q11	1854-0071		XSTR SI NPN	01295	SKA1124
A20Q12	1854-0022		XSTR SI NPN	03877	ST 1657
A20Q13	1854-0022		XSTR SI NPN	03877	ST 1657
A20Q14	1854-0071		XSTR SI NPN	01295	SKA1124
A20Q15	1854-0022		XSTR SI NPN	03877	ST 1657
A20Q16	1854-0071		XSTR SI NPN	01295	SKA1124
A20Q17	1854-0071		XSTR SI NPN	01295	SKA1124
A20Q18	1854-0071		XSTR SI NPN	01295	SKA1124
A20Q19	1854-0071		XSTR SI NPN	01295	SKA1124
A20Q20	1854-0384	2	XSTR SI NPN	02375	2N5184
A20Q21	1854-0384		XSTR SI NPN	02375	2N5184
A20R1	0757-0462	2	R FXD 75K OHM 1% 1/8W	19701	MF4CT-0
A20R2	0757-0123	2	R FXD 34.8K OHM 1% 1/8W	01295	
A20R3	0757-0280		R FXD 1K OHM 1% 1/8W	75042	CEAT-0
A20R4	0757-0446		R FXD 15K OHM 1% 1/8W	19701	MF4C
A20R5	0757-0447	1	R FXD 16.2K OHM 1% 1/8W	19701	MF4CT-0
A20R6	0698-3457		R FXD 316K OHM 1% 1/8W	19701	MF4CT-0
A20R7	0757-0462		R FXD 75K OHM 1% 1/8W	19701	MF4CT-0
A20R8	0757-0123		R FXD 34.8K OHM 1% 1/8W	01295	
A20R9	0757-0280		R FXD 1K OHM 1% 1/8W	75042	CEAT-0
A20R10	0757-0446		R FXD 15K OHM 1% 1/8W	19701	MF4C
A20R11	0698-3260	2	R FXD 464K OHM 1% 1/8W	19701	MF4CT-0
A20R12	0757-0274		R FXD 1.21K OHM 1% 1/8W	19701	MF4CT-0
A20R13	0757-0401		R FXD 100 OHM 1% 1/8W	19701	MF4CT-0
A20R14	0698-3136		R FXD 17.8K 1% 1/8W	19701	MF4CT-0
A20R15	0757-0442		R FXD 10K OHM 1% 1/8W	19701	MF4C
A20R16	0757-0442		R FXD 10K OHM 1% 1/8W	19701	MF4C

Abbreviations are listed in the introduction to this section

Table 3-1 Replaceable Parts (continued)

Ref Desig	HP Part No	TQ	Description	Mfr	Mfr Part No
A2OR17	0757-0289		R FXD 13.3K OHM 1% 1/8W	75042	CEAT-0
A2OR18	0757-0442		R FXD 10K OHM 1% 1/8W	19701	MF4C
A2OR19	0757-0442		R FXD 10K OHM 1% 1/8W	19701	MF4C
A2OR20	0757-0442		R FXD 10K OHM 1% 1/8W	19701	MF4C
A2OR21	0757-0760	1	R FXD 20K OHM 1% 1/4W	19701	MF52C T-0
A2OR22	2100-2030	1	R VAR 20K OHM 10% 1/2W LIN	73138	62P-R20K
A2OR23	0698-0086	1	R FXD 2.87K OHM 1% 1/4W	19701	MF52CT-0
A2OR24	0698-3162		R FXD 46.4K OHM 1% 1/8W	19701	MF4CT-0
A2OR25	0698-3162		R FXD 46.4K OHM 1% 1/8W	19701	MF4CT-0
A2OR26	0757-0747		R FXD 5.11K OHM 1% 1/4W	19701	MF52CT-0
A2OR27	0757-0751	1	R FXD 7.5K OHM 1% 1/4W	19701	MF52CT-0
A2OR28	0698-3418	1	R FXD 26.1K OHM 1% 1/2W	19701	MF7CT-0
A2OR29	0757-0399	1	R FXD 82.5 OHM 1% 1/8W	19701	MF4CT-0
A2OR30	0757-0469	4	R FXD 150K OHM 1% 1/8W	19701	MF4CT-0
A2OR31	0757-0469		R FXD 150K OHM 1% 1/8W	19701	MF4CT-0
A2OR32	0757-0280		R FXD 1K OHM 1% 1/8W	75042	CEAT-0
A2OR33	0760-0004	1	R FXD 20K OHM 2% 2W	75042	RG-42
A2OR34	0757-0770		R FXD 56.2K OHM 1% 1/4W	19701	MF52C T-0
A2OR35	0757-0342	1	R FXD 100K OHM 1% 1/4W	19701	MF52CT-0
A2OR36	0757-0403	1	R FXD 121 OHM 1% 1/8W	19701	MF4CT-0
A2OR37	0757-0442		R FXD 10K OHM 1% 1/8W	19701	MF4C
A2OR38	0698-3153		R FXD 3.83K OHM 1% 1/8W	19701	MF4CT-0
A2OR39	0757-0465		R FXD 100K OHM 1% 1/8W	19701	MF4CT-0
A2OR40	0698-5490		R FXD 2K OHM 1% 1/8W	91637	CMF-1/10-32T-2
A2OR41	0757-0857	1	R FXD 82.5K OHM 1% 1/2W	19701	MF7CT-0
A2OR42	0698-3136		R FXD 17.8K 1% 1/8W	19701	MF4CT-0
A2OR43	0757-0463	2	R FXD 82.5K OHM 1% 1/8W	19701	MF4CT-0
A2OR44	2100-2031	1	R VAR 50K OHM 10% 1/2W LIN	73138	62-212-1
A2OR45	0757-0199		R FXD 21.5K OHM 1% 1/8W	19701	MF4CT-0
A2OR46	0686-0275	1	R FXD 2.7 OHM 5% 1/2W	01121	EB27G5
A2OR47	0757-0199		R FXD 21.5K OHM 1% 1/8W	19701	MF4CT-0
A2OR48	0757-0346	1	R FXD 10 OHM 1% 1/8W	75042	CEA
A2OR49	0757-0439		R FXD 6.81K OHM 1% 1/8W	19701	MF4C
A2OR50	0757-0469		R FXD 150K OHM 1% 1/8W	19701	MF4CT-0
A2OR51	0698-4037		R FXD 46.4 OHM 1% 1/8W	75042	CEAT-0
A2OR52	0698-0084		R FXD 2.15K OHM 1% 1/8W	19701	MF4CT-0
A2OR53	0698-3153		R FXD 3.83K OHM 1% 1/8W	19701	MF4CT-0
A2OR54	2100-2497	1	R VAR 2K OHM 10% 1/2W LIN	73138	62-207-1
A2OR55	0698-3156	2	R FXD 14.7K OHM 1% 1/8W	19701	MF4CT-0
A2OR55	0698-3156		R FXD 14.7K OHM 1% 1/8W	19701	MF4CT-0
A2OR56	0698-4937	1	R FXD 45.3K OHM 1% 1/2W	19701	MF7CT-0
A2OR57	0757-0464	1	R FXD 90.9K OHM 1% 1/8W	01295	
A2OR58	0698-3150		R FXD 2.37K OHM 1% 1/8W	19701	MF4CT-0
A2OR59	0757-0482		R FXD 511K OHM 1% 1/8W	19701	MF5C T-0
A2OR60	0757-0442		R FXD 10K OHM 1% 1/8W	19701	MF4C
A2OR61	0757-0442		R FXD 10K OHM 1% 1/8W	19701	MF4C
A2OR62	0757-0442		R FXD 10K OHM 1% 1/8W	19701	MF4C
A2OR63	0757-0449		R FXD 20K OHM 1% 1/8W	19701	MF4CT-0
A2OR64	0757-0442		R FXD 10K OHM 1% 1/8W	19701	MF4C
A2OR65	0698-3136		R FXD 17.8K 1% 1/8W	19701	MF4CT-0
A2OR66	0757-0289		R FXD 13.3K OHM 1% 1/8W	75042	CEAT-0
A2OR67	0757-0469		R FXD 150K OHM 1% 1/8W	19701	MF4CT-0
A2OR68	0757-0279		R FXD 3.16K OHM 1% 1/8W	75042	CEAT-0
A2OR69	0757-0442		R FXD 10K OHM 1% 1/8W	19701	MF4C
A2OR70	0757-0482		R FXD 511K OHM 1% 1/8W	19701	MF5C T-0

Abbreviations are listed in the introduction to this section

Table 3-1 Replaceable Parts (continued)

Ref Desig	HP Part No	TQ	Description	Mfr	Mfr Part No
A20R71	0757-0442		R FXD 10K OHM 1% 1/8W	19701	MF4C
A20R72	0757-0482		R FXD 511K OHM 1% 1/8W	19701	MF5C T-0
A20R73	0698-3152	1	R FXD 3.48K OHM 1% 1/8W	19701	MF4CT-0
A20R74	0757-0278	1	R FXD 1.78K OHM 1% 1/8W	75042	CEAT-0
A20R75	0757-0442		R FXD 10K OHM 1% 1/8W	19701	MF4C
A20R76	2100-2655	1	R VAR 100K OHM 10% 1/2W LIN	21030	62-213-1
A20R77	0698-3162		R FXD 46.4K OHM 1% 1/8W	19701	MF4CT-0
A20R78	0757-0463		R FXD 82.5K OHM 1% 1/8W	19701	MF4CT-0
A20R79	0698-3455	1	R FXD 261K OHM 1% 1/8W	19701	MF4CT-0
A20R80	0698-3260		R FXD 464K OHM 1% 1/8W	19701	MF4CT-0
A20R81	0757-0289		R FXD 13.3K OHM 1% 1/8W	75042	CEAT-0
A20R82	0698-3162		R FXD 46.4K OHM 1% 1/8W	19701	MF4CT-0
A20R83	0757-0401		R FXD 100 OHM 1% 1/8W	19701	MF4CT-0
A20R84	0698-3444		R FXD 316 OHM 1% 1/8W	19701	MF4CT-0
A20R85	0698-3430	1	R FXD 21.5 OHM 1% 1/8W	19701	MF4CT-0
A42			HV CABLE HARNESS ASSY		
A42R1	0757-0344	1	R FXD 1M OHM 1% 1/4W	19701	MF52CT-0
A42XV1	1200-0037	1	SOCKET #CRT BASE#	72825	9709-4
	1200-0408	1	COVER #SOCKET#	14493	5040-5085
	1200-0050	1	PIN #SOCKET# #TQ 10#	72825	9553-1

Abbreviations are listed in the introduction to this section

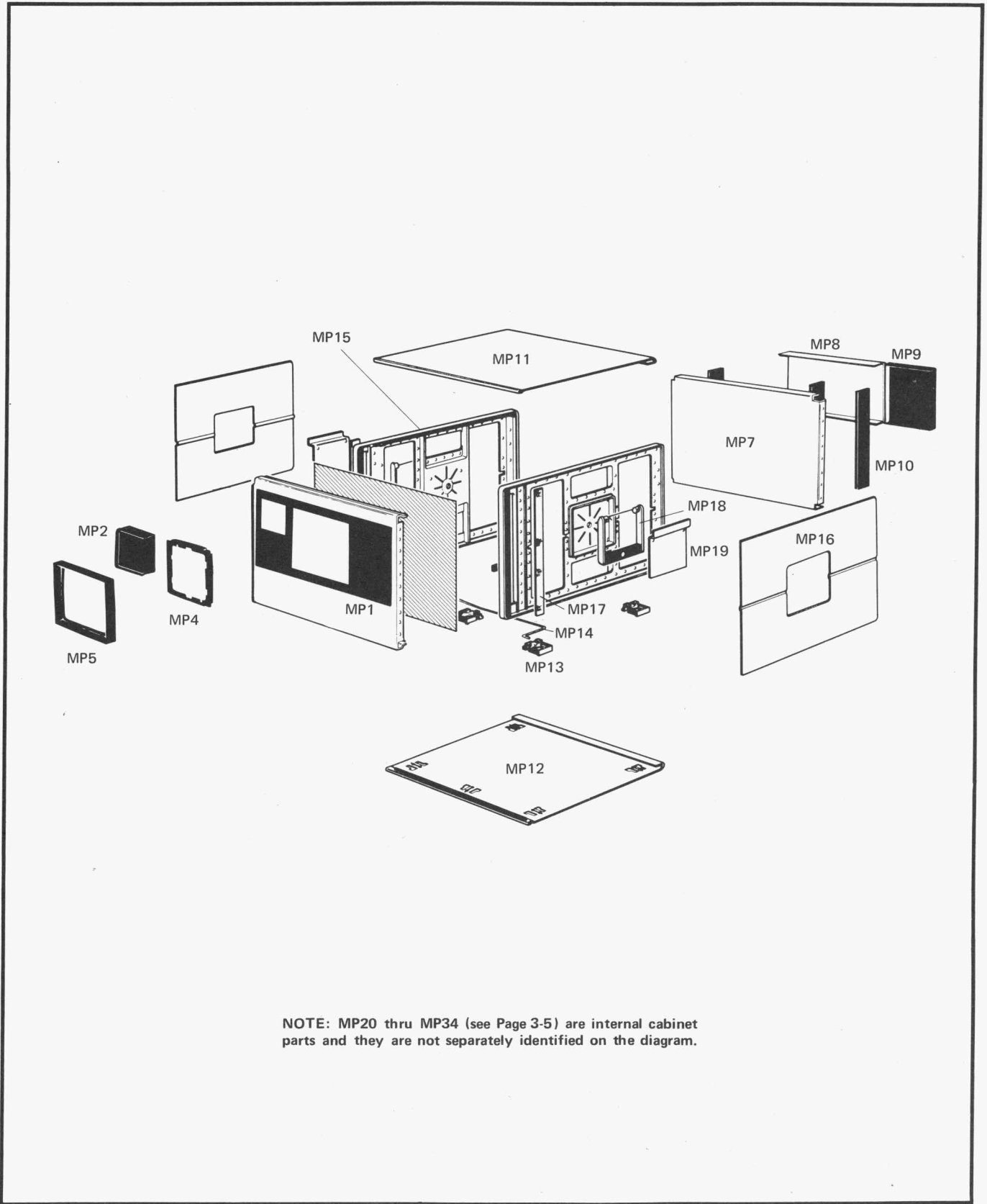

Figure 3-1 Location of cabinet components

Table 3-2 Code List of Manufacturers

The following code numbers are from the Federal Supply Code for Manufacturers Cataloging Handbooks H4-1 (Name to Code) and H4-2 (Code to Name). Alphabetical codes have been arbitrarily assigned to suppliers not appearing in the H4 handbooks.

Code No	Manufacturer	Address	Code No	Manufacturer	Address
01121	ALLEN BRADLEY CO.	MILWAUKEE WIS.	71450	CTS CORP.	ELKHARD IND.
01295	TEXAS INSTRUMENTS INC.	DALLAS TEXAS	71590	CENTRALAB DIV. OF GLOBE	MILWAUKEE WIS.
02375	AMERICAN INSULATING CO.	PHILADELPHIA PA.		-UNION	
02660	AMPHENOL CORP.	BROADVIEW ILL.	71785	CINCH MFG. CO.	CHICAGO ILL.
02735	R.C.A. SEMICONDUCTOR DIV.	SOMERVILLE N.J.	72136	ELECTRO MOTIVE MFG. CO.	WILLIMANTIC CONN.
03508	GENERAL ELECTRIC CO.	SYRACUSE N.Y.	72825	EBY HUGH H INC.	PHILADELPHIA PA.
03877	TRANSITRON ELECT. CORP.	WAKEFIELD MASS.	72982	ERIE TECH. PRODUCTS INC.	ERIE PA.
03888	PYROFILM RES. CO. INC.	CEDAR KNOLLS N.J.	73138	BECKMAN INSTRUMENTS INC.	FULLERTON CALIF.
04713	MOTOROLA SEMI. CON. INC.	PHOENIX ARIZ.	73957	GROOV-PIN CORP.	RIDGEFIELD N.J.
05820	WAKEFIELD ENGINEERING	WAKEFIELD MASS.	75042	I.R.C. DIV. OF TRW INC.	PHILADELPHIA PA.
07263	FAIRCHILD C & I CORP.	MTN. VIEW CALIF.	75915	LITTLEFUSE INC.	PLAINES ILL.
07910	CONTINENTAL DEVICE CORP.	HAWTHORNE CALIF.	76530	CINCH-MONADOCK DIV. OF	CITY OF INDUSTRY
07933	RAYTHEON CO. COMP. DIV.	MOUNTAIN VIEW CALIF.		-UNITED-CARR INC.	CALIF.
08806	GENERAL ELECTRIC CO.	CLEVELAND OHIO	76854	OAK MFG. CO.	CRYSTAL LAKE ILL.
	-MIN. LAMP DEPT.		77764	RESISTANCE PRODUCTS CO.	HARRISBURG PA.
09684	SANGAMO CO. LTD.	LEASIDE ONTARIO	79727	CONTINENTAL-WIRT	PHILADELPHIA PA.
12040	NAT. SEMICONDUCTOR CORP.	DANBURY CONN.		-ELECTRONICS CORP.	
12065	TRANSITRON ELEC. CORP.	BOSTON MASS.	81073	GRAYHILL INC.	LA GRANGE ILL.
13715	FAIRCHILD C & I CORP.	SAN RAFAEL CALIF.	82389	SWITCHCRAFT INC.	CHICAGO ILL.
14493	HEWLETT-PACKARD CO.	LOVELAND COLO.	91260	CONNOR SPRING MFG.	SAN FRANCISCO CALIF.
14655	CORNELL-DUBLIER ELEC. CORP.	NEWARK N.J.	91418	RADIO MATERIALS CO.	CHICAGO ILL.
16299	CORNING GLASS WORKS	RALEIGH N.C.	91506	AUGAT INC.	ATTLEBORO MASS.
16352	COMPUTER DIODE CORP.	SOUTH FAIRLAWN N.J.	91637	DALE ELECTRONICS INC.	COLUMBUS NEBR.
17856	SILICONIX INC.	SUNNYVALE CALIF.	93332	SYLVANIA ELECTRIC PROD.	WOBURN MASS.
19701	ELECTRA MFG. CO.	INDEPENDENCE KANS.	95238	CONTINENTAL CONNECTOR	WOODSIDE NY.
20846	ERIE MFG. CO.	MILWAUKEE WIS.	95712	BENDIX CORP. MICROWAVE	FRANKLIN IND.
21030	BECKMAN INSTR. INC.	TORONTO ONTARIO		-DEVICES DIVISION	
21845	SOLITRON DEVICES INC.	RIVIERA BEACH FLA.	99800	DELEVAN ELECTRONICS CORP.	EAST AURORA NY.
23936	PAMOTOR INC.	SAN FRANCISCO CALIF.	E0001	TEXAS INSTRUMENTS LTD.	BEDFORD BEDS.
27264	MOLEX PRODUCTS CO.	DOWNERS GROVE ILL.	E0007	HEWLETT-PACKARD LTD.	SOUTH QUEENSFERRY
28106	SYLVANIA ELEC. PROD. INC.	BURLINGTON IOWA		-	WEST LOTHIAN
28480	HEWLETT-PACKARD CO.	PALO ALTO CALIF.	E0013	PAINTON & CO. LTD.	KINGSTHORPE
56137	SPAULDING FIBRE CO. INC.	TONAWANDA N.Y.		-	NORTHAMPTON
56289	SPRAGUE ELECTRIC CO.	ADAMS MASS.	E0016	UNION CARBIDE/INTERSIL	AYCLIFFE CO. DURHAM
71400	BUSSMANN MFG. DIV. OF	ST LOUIS MO.	E0024	ERIE ELECTRONICS LTD	GREAT YARMOUTH
	-MCGRAW-EDISON CO.				NORFOLK

SECTION IV

SYSTEM TROUBLESHOOTING

4-1 INTRODUCTION

4-2 This section contains a diagnostic procedure for determining the faulty instrument in the 3721A/3720A System when a system failure occurs. Before troubleshooting the System, check that the 3721A is functioning correctly by carrying out the Performance Check given in Section III of the 3721A Service Manual. Although covering most faults likely to occur in practice, the System troubleshooting procedure is not intended as an infallible method for every possible trouble. For faults not covered here please contact your nearest Hewlett-Packard Service Office. Addresses are given at the back of this manual.

4-3 USING TROUBLESHOOTING SECTION

4-4 Paragraph 4-12 gives the settings for the controls on the 3721A and 3720A required before starting to troubleshoot the System. Except where indicated in the appropriate Flow, these settings should be maintained throughout the troubleshooting procedure.

4-5 When there is a fault in the System and the problem area is unknown, start at Flow A and work through to Flow D to isolate the faulty instrument.

When the problem area is known refer to the appropriate Flow. Table 4-1 lists the Flow charts.

Table 4-1 Flow charts

Flow	Problem Area
A	Control faults
B	Display Sensitivity faults
C	Data Transfer faults
D	Other Transferred Signals faults

NOTE: When there is a fault in the System and it occurs *only* when displaying Modulus, Log Mod and/or Phase, then the fault is in the 3720A.

4-6 When carrying out System troubleshooting the rear panel connector wiring details are available for reference in Section V of this manual.

4-7 Once the fault has been localised to one of the instruments refer to Table 4-2 for the appropriate action to be taken.

Table 4-2 3721A/3720A System repair procedure

Faulty Instrument	Action
3721A Correlator	Refer to 3721A Service Manual
15549A Interface Accessory (Assembly and Cable)	Refer to 15549A Operating and Service Manual
3720A Spectrum Display	Return 3720A to your nearest Hewlett-Packard Service Office for repair

4-8 TEST EQUIPMENT

4-9 Table 4-3 lists the test equipment required to carry out the troubleshooting procedure. Other equipment with similar specifications may be substituted if desired.

4-10 Logic Probe

4-11 The *hp* 10525A Logic Probe is used extensively in troubleshooting the 3721A/3720A System. Power for the probe is supplied from the LOGIC

PROBE connector on the rear panel of the 3721A Correlator. This probe will indicate three logical conditions:

- a. When the lamp is glowing brightly, a steady >2.5V level is present.
- b. When the lamp is extinguished, a steady <1.0V level is present.
- c. When the lamp flashes or glows dimly, a pulse train is present, the rate of flashing being an indication of the pulse repetition rate.

Table 4-3 Test equipment required for System Troubleshooting

Instrument	Specifications	Recommendation
Logic Probe	Indicates TTL logic levels and pulse trains	<i>hp</i> 10525A
Oscilloscope	50MHz bandwidth Dual vertical inputs Main and delayed timebase External triggering facility	<i>hp</i> 180A/1801A/1821A with two <i>hp</i> 10004A 10:1 Voltage Divider Probes

4-12 SYSTEM TROUBLESHOOTING CONTROLS SET-UP

CAUTION

A high intensity CRT display over an extended period of time may cause burn damage to the storage mesh or phosphors of the 3720A CRT.

4-13 Procedure

1. Set controls.

Set 3720A controls:

SCALE FACTOR VERT
 INTENSITY fully ccw
 PERSISTENCE MIN
 STORAGE TIME MAX
 INPUT 1
 DATA 1
 VERTICAL GAIN MIN
 HORIZONTAL GAIN MIN
 CALIBRATION OFF
 RECORD SCAN
 INTERPOLATION ccw (not AUTO)

Set 3721A controls:

FUNCTION AUTOCORRELATION A
 A INPUT RMS VOLTS 4 – 1
 AC/DC (A) DC
 DITHER OFF
 AVERAGING SUMMATION
 NUMBER OF SAMPLES N 1 x 1024
 TIMESCALE 333 μ S
 DISPLAY GAIN MIN
 DISPLAY/CAL DISPLAY

2. Switch on 3721A and 3720A and allow 20 minutes warm-up time.
3. Press 3721A RESET, then RUN.
4. Adjust INTENSITY controls on 3721A and 3720A to obtain normal brightness traces on the respective CRT's. Both instruments should display a horizontal trace positioned along the major axis of the graticule.
5. Check the 3721A/3720A System for faults by following Flow A, B, C and/or D, as appropriate.

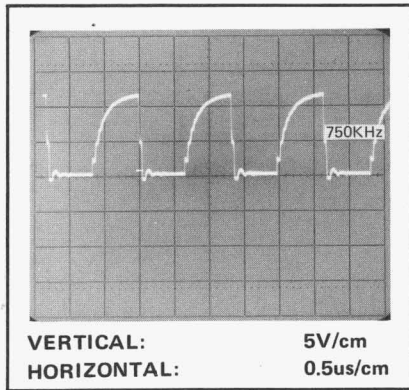

Figure 4-1 750KHz

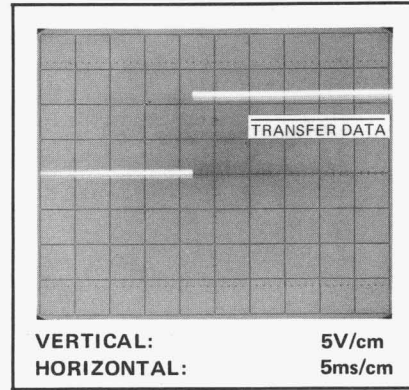

Figure 4-2 Transfer Data duration

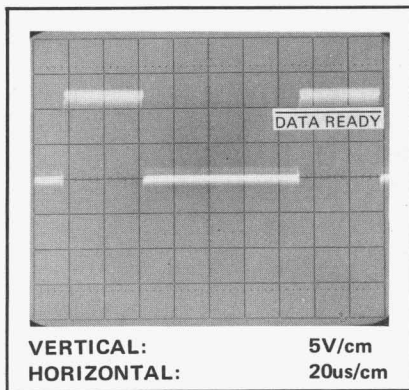

Figure 4-3 Data Ready

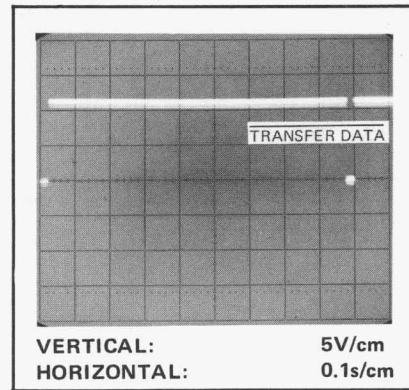

Figure 4-4 Transfer Data repetition rate

4-14 FLOW A – Control Faults

4-15 Procedure

1. Set controls as in Paragraph 4-12.

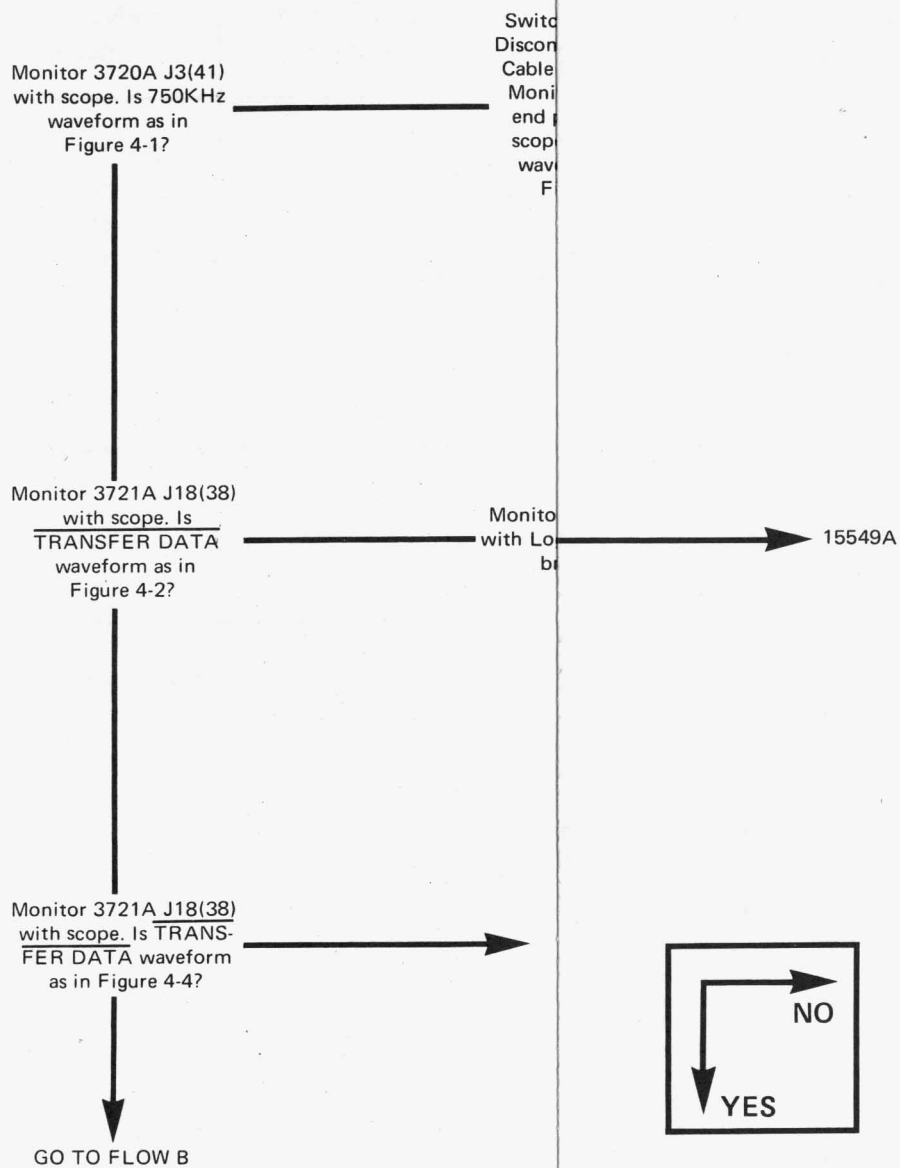

Table 4-4 Range transfer check

3721A Controls			3720A DISPLAY SENSITIVITY Reading	3721A DISPLAY SENSITIVITY Reading
A INPUT RMS VOLTS	DISPLAY GAIN	AVERAGING		
1 - 2	MIN	EXPONENTIAL x 1	1.0 V ² /div	1.0 x 1 V ² /CM
.4 - 1	MIN	EXPONENTIAL x 1	2.0 x 10 ⁻¹ V ² /div	2.5 x 10 ⁻¹ V ² /CM
.2 - .4	MIN	EXPONENTIAL x 1	5.0 x 10 ⁻² V ² /div	5.0 x 10 ⁻² V ² /CM
.2 - .4	MIN	EXPONENTIAL x 10	5.0 x 10 ⁻³ V ² /div	5.0 x 10 ⁻³ V ² /CM
.2 - .4	MIN	EXPONENTIAL x 100	5.0 x 10 ⁻⁴ V ² /div	5.0 x 10 ⁻⁴ V ² /CM
.2 - .4	int	EXPONENTIAL x 100	2.0 x 10 ⁻⁴ V ² /div	2.0 x 10 ⁻⁴ V ² /CM
.1 - .2	int	EXPONENTIAL x 100	5.0 x 10 ⁻⁵ V ² /div	5.0 x 10 ⁻⁵ V ² /CM
.04 - .1	MAX	EXPONENTIAL x 100	5.0 x 10 ⁻⁶ V ² /div	5.0 x 10 ⁻⁶ V ² /CM

Table 4-5 Range data logic check

3720A DISPLAY SENSITIVITY Reading	3721A DISPLAY SENSITIVITY Reading	3720A J3/ 3721A J18 Pin*
1.0	1.0	29
2.0	2.0	33
2.0	2.5	27
5.0	5.0	-
-	x 1	-
x 10 ⁻¹	x 10 ⁻¹	31
x 10 ⁻²	x 10 ⁻²	34
x 10 ⁻³	x 10 ⁻³	28
x 10 ⁻⁴	x 10 ⁻⁴	26
x 10 ⁻⁵	x 10 ⁻⁵	30
x 10 ⁻⁶	x 10 ⁻⁶	32

*All of these pins should be high (+12V) except those of any displayed characters which should be as shown in Figure 4-5.

4-19 FLOW C – Data Transfer Faults

4-20 Procedure

1. Set controls as in Paragraph 4-12 except as follows:

Set 3721A controls:

FUNCTION PROBABILITY DENSITY
NUMBER OF SAMPLES N 32 x 1024

2. Connect 3721A HORIZ SCOPE output to 3721A A INPUT.
3. Press 3721A RESET, then RUN.
4. When 3721A TIME CONSTANT lamp lights press 3721A HOLD.

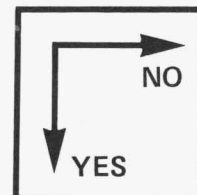
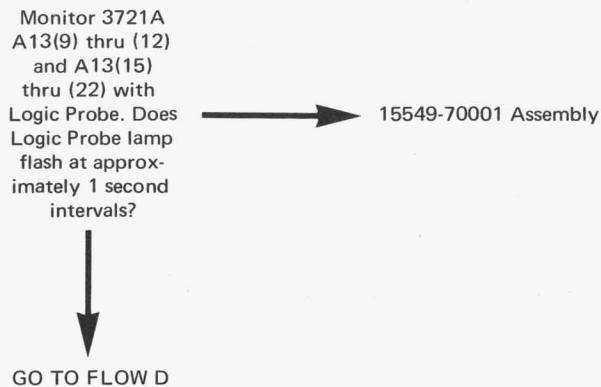

Table 4-6 Timescale transfer check

3721A TIMESCALE Setting	3720A J3/3721A J18 Pins					
	20	21	22	23	24	45
≥333μS	0	1	1	1	1	0
≥33μS	0	1	1	1	1	1
≥1μS	0	1	1	1	0	0
333mS	1	0	1	1	0	1
100mS	1	0	1	0	1	0
33.3mS	1	0	1	0	1	1
10mS	1	0	0	1	1	0
3.33mS	1	0	0	1	1	1
1mS	1	0	1	1	1	0
333μS	1	1	1	1	1	1
100μS	1	1	0	1	1	0
33.3μS	1	1	0	1	1	1
10μS	1	1	1	0	1	0
3.33μS	1	1	1	0	1	1
1μS	1	1	1	1	0	0

1 = lamp on 0 = lamp off

4-25 FLOW D(b) – Gain Correction Factors Transfer Faults

4-26 Procedure

- Set controls as in Paragraph 4-12 except as follows:

Set 3721A controls:

A INPUT RMS VOLTS see Table 4-7

DISPLAY GAIN see Table 4-7

Set 3721A A INPUT
RMS VOLTS and
DISPLAY GAIN
switches according
to Table 4-7. Monitor
3720A J3(46) and
(47) with Logic
Probe. Is Logic Probe
condition correct?



Repeat check. Monitor
3721A J18(46) and
(47) with Logic Probe.
Is Logic Probe condition
correct?

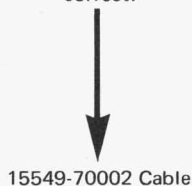

3721A

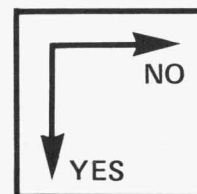

Table 4-7 Gain correction factors check

3721A Control Settings		3720A J3/3721A J18 Pins	
A INPUT RMS VOLTS	DISPLAY GAIN	46	47
.2 – .4	MIN	1	0
.4 – 1	MIN	0	1
.4 – 1	int	0	0

1 = lamp on 0 = lamp off

4-27 FLOW D(c) – Signal Recovery Transfer Faults

4-28 Procedure

1. Set controls as in Paragraph 4-12 except as follows:

Set 3721A controls:

FUNCTION see Table 4-8

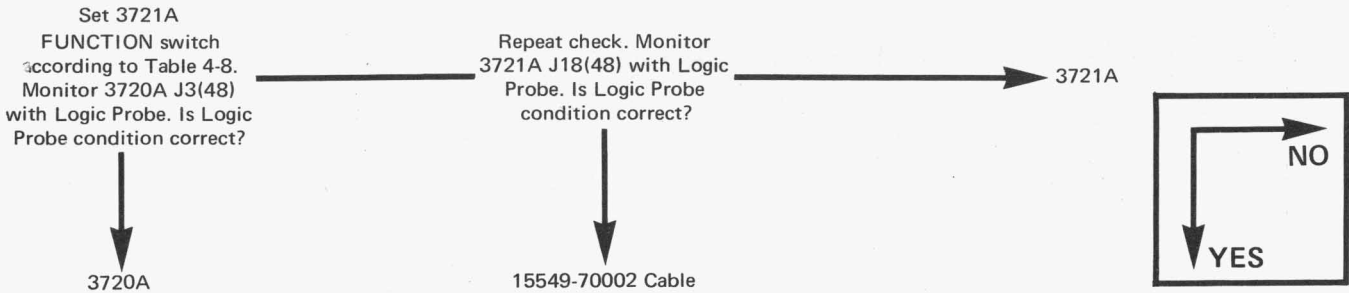

Table 4-8 Signal recovery transfer check

3721A FUNCTION Setting	3720A J3(48)/3721A J18(48)
SIGNAL RECOVERY	0
PROBABILITY INTEGRAL	1
PROBABILITY DENSITY	1
AUTOCORRELATION A	1
AUTOCORRELATION B	1
CROSSCORRELATION A DELAYED	1
CROSSCORRELATION B DELAYED	1

1 = lamp on 0 = lamp off

SECTION V

SCHEMATICS, COMPONENT LOCATIONS, DIAGRAMS

5-1 INTRODUCTION

5-2 This section contains Component Location diagrams and Schematics for all the assemblies in the 3720A. For convenience, and to aid in usage, information on each assembly is contained within assembly packages, listed in assembly designator order.

5-3 DRAWING SYMBOLS

5-4 Figures 5-1 and 5-4 show drawing symbols and standards used throughout this section whilst Figure 5-2 indicates the internal layout of the digital integrated circuits used in the 3720A.

5-5 ASSEMBLY PACKAGES

5-6 Each assembly package comprises a Component Location (and Component Identification Grid where applicable), and Schematic.

5-7 Locating Assembly Packages

5-8 Each assembly package is marked at the bottom right hand corner of the right hand pull-out page with a large identification number corresponding to that assembly designator, eg, assembly A11 is marked A11. Since all interconnections between assemblies are labelled by assembly designator and pin number, this should aid when referring to an assembly.

5-9 THEORY OF OPERATION

5-10 Functional Diagram

5-11 Figure 5-3 shows a simplified Functional Diagram of the 3720A indicating the signal flow through the instrument, the main processing steps and the function of the front panel controls.

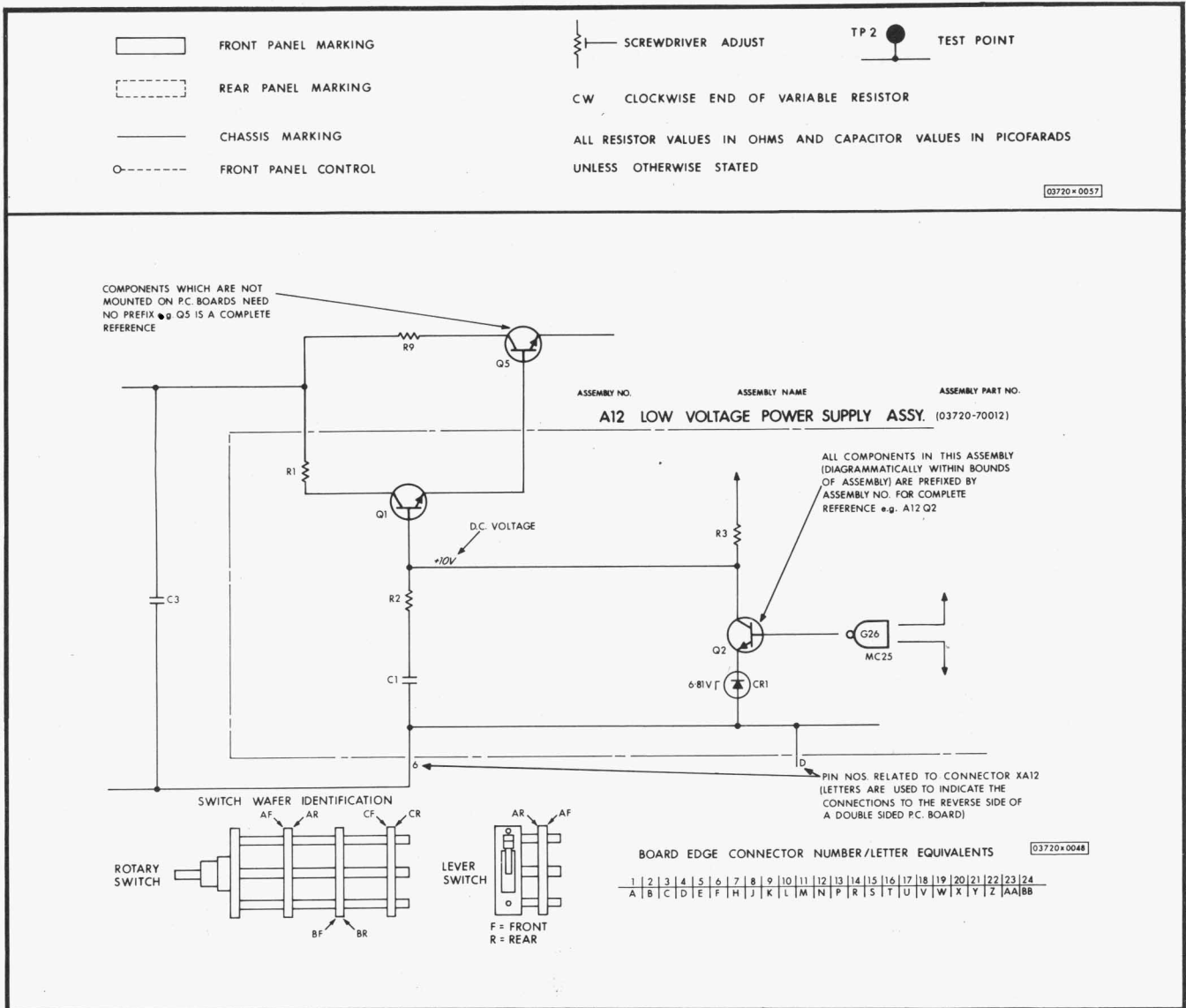
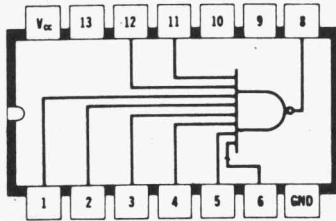

Figure 5-1 Guide to schematics

1820 - 0070 (SN7430N)

8-input NAND gate



1820 - 0071 (SN7440N)

Dual 4-input NAND buffer

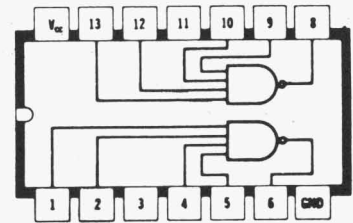

1820 - 0085 (SN7460N)

Dual 4-input expander

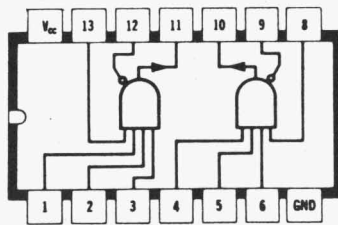

1820 - 0107

Interface buffer gate

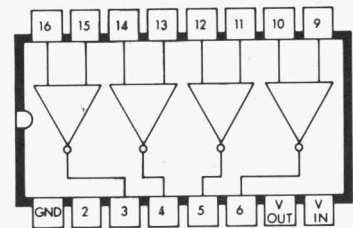

1820 - 0328 (SN7402N)

Quadruple 2-input NOR gate

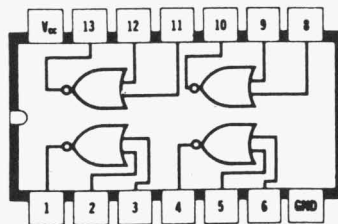

1820 - 0370 (SN74H00N)

Quadruple 2-input NAND gate

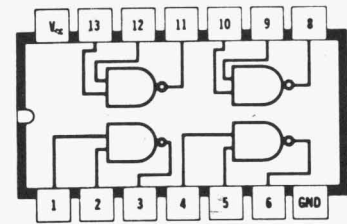
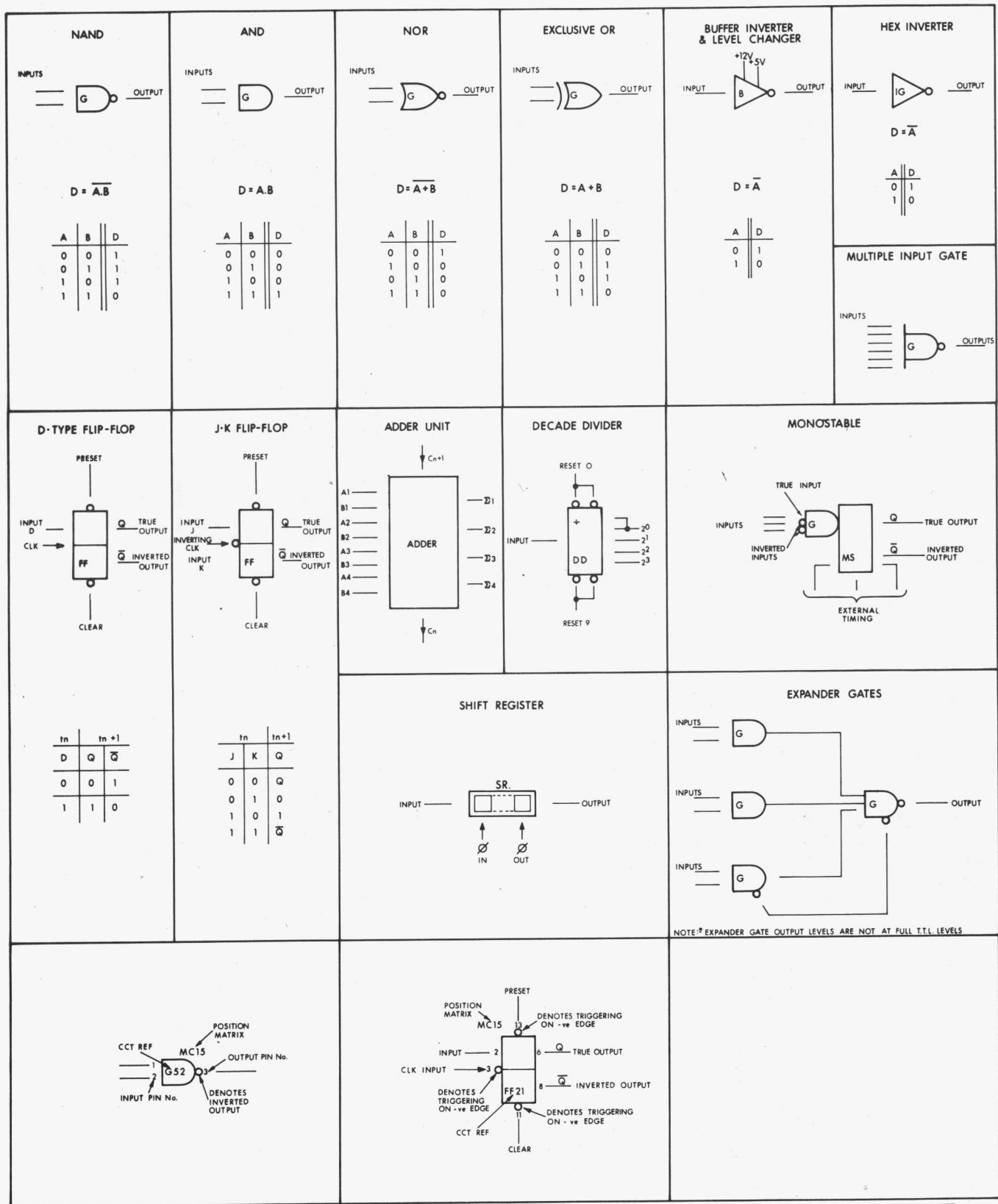

Figure 5-2 Logic package outlines



03720 * 0051

Figure 5-4 Guide to logic symbols

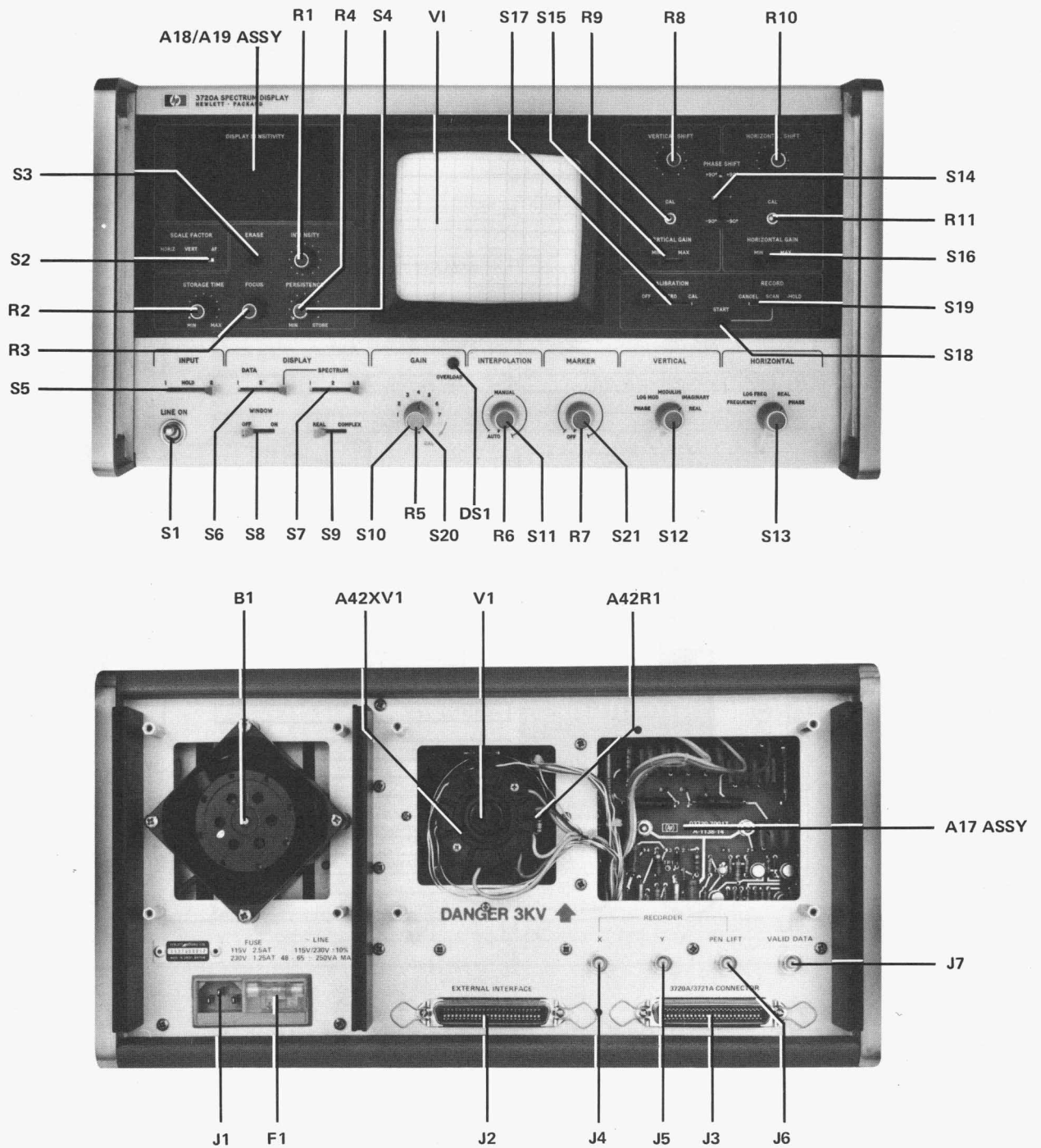

Figure 5-5 Location of components (front and rear panels)

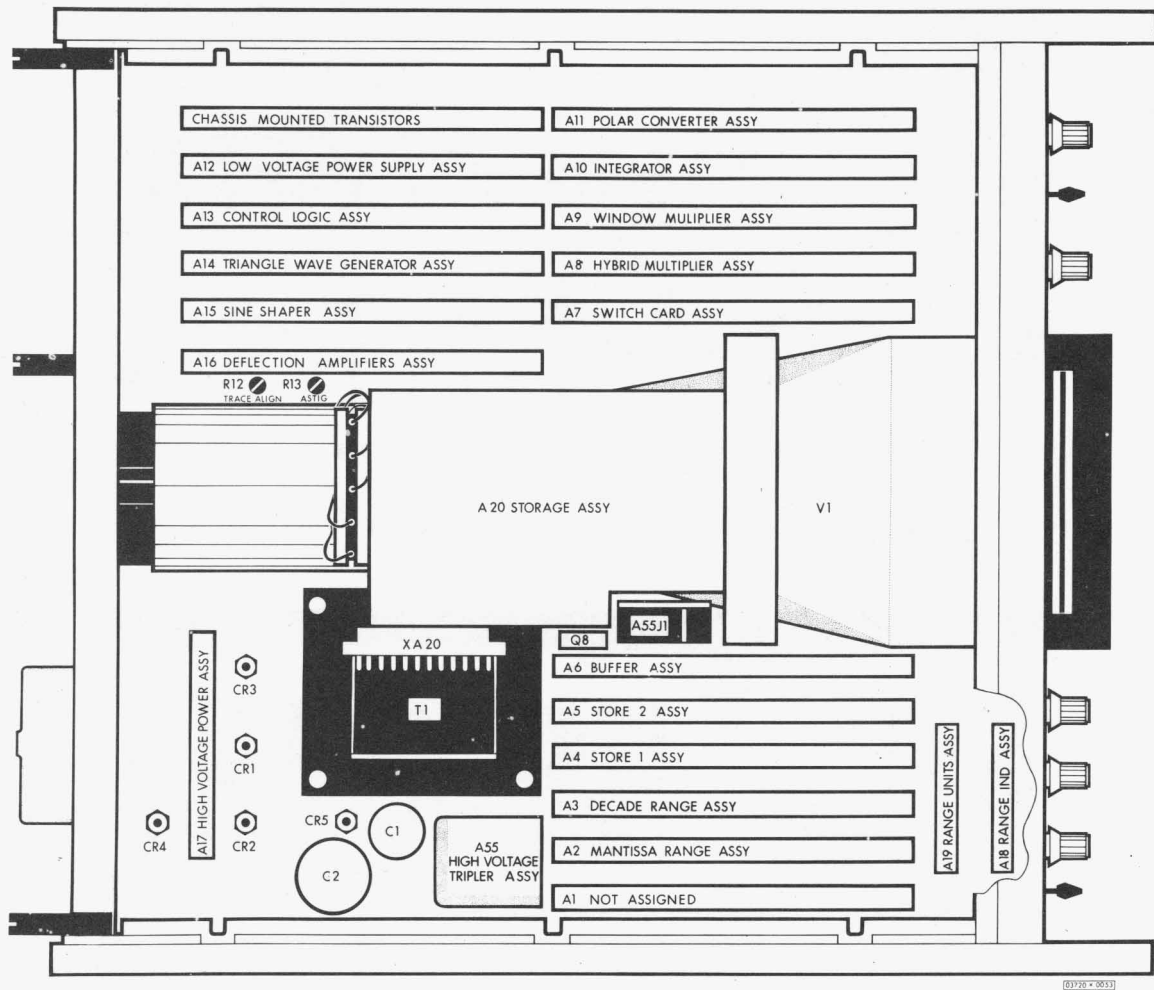

Figure 5-6 Location of assemblies and chassis mounted components (top view)

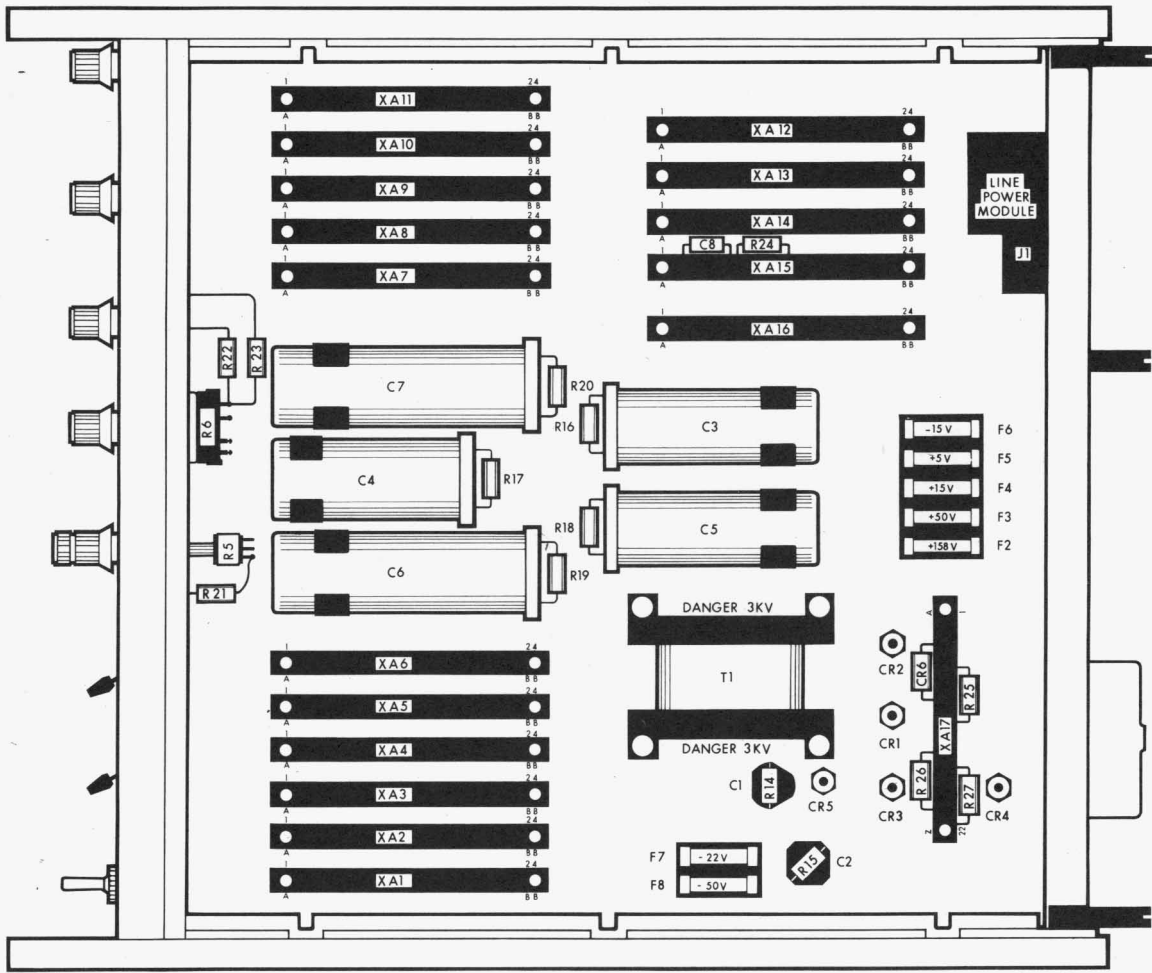
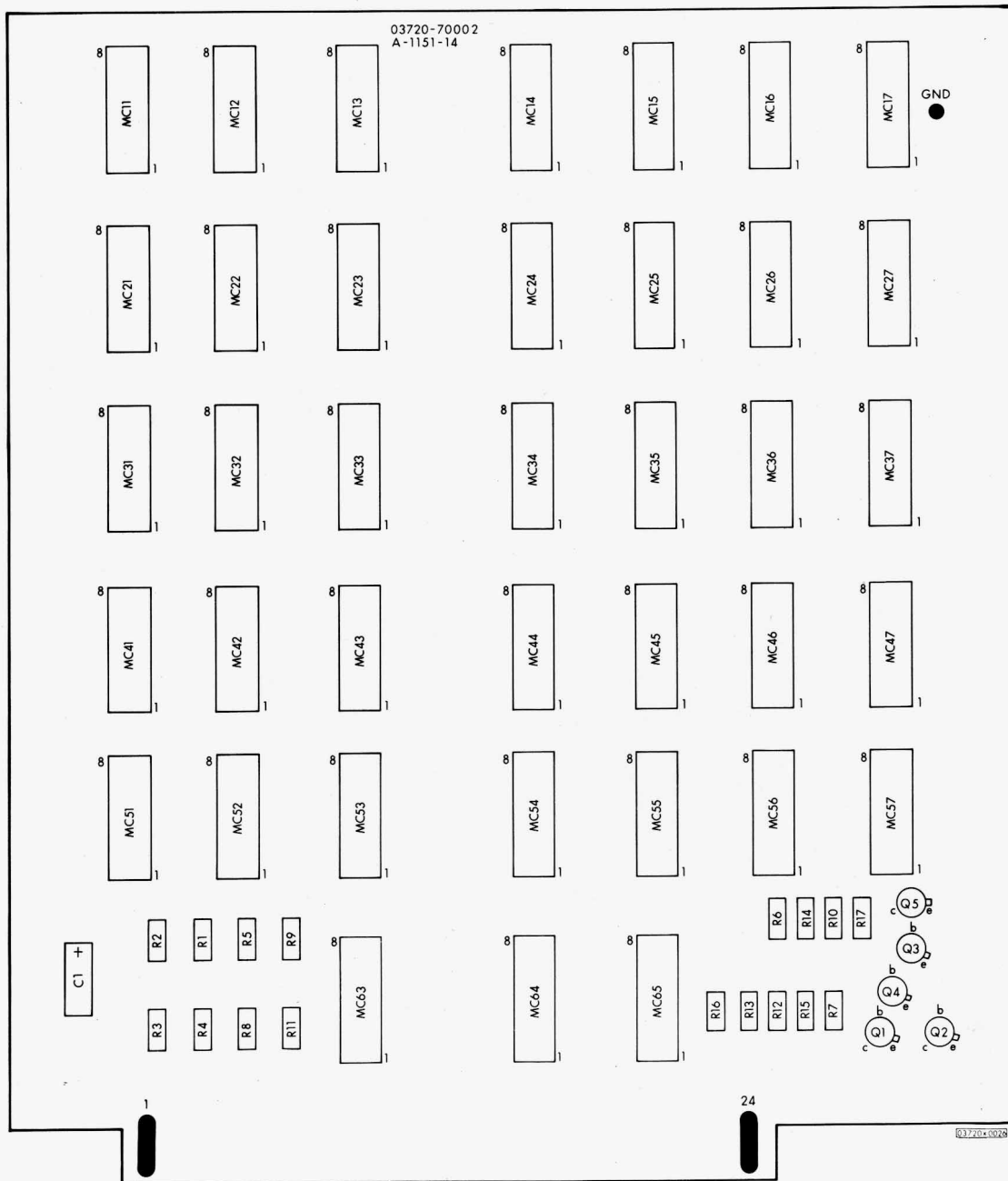

Figure 5-7 Location of assemblies and chassis mounted components (underside view)

HP
Hewlett-Packard Company

A1

NOT ASSIGNED



WWW.HPARCHIVE.COM
For Free Distribution Only

Figure A2-1 Component location, A2

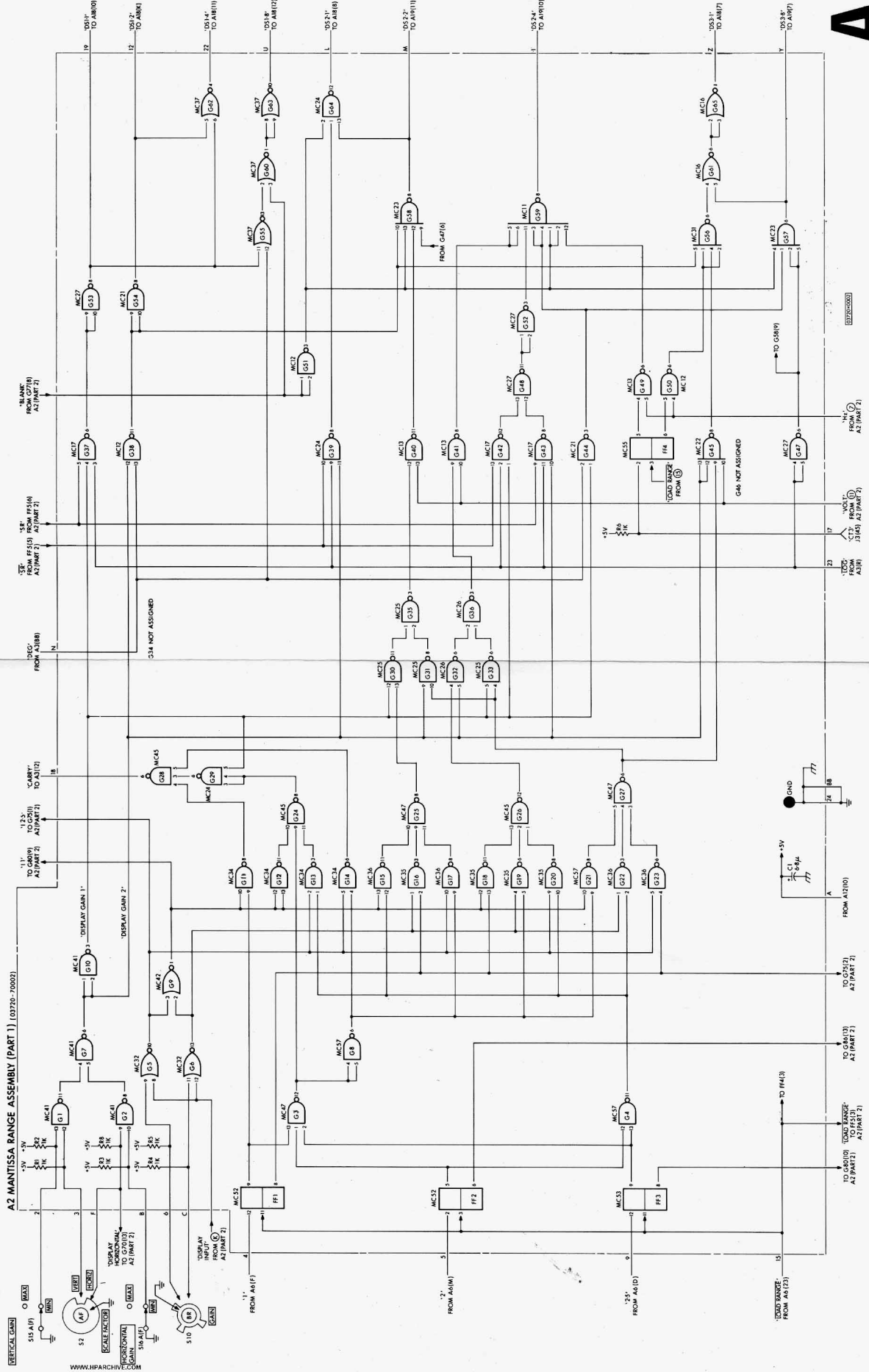

A2

Figure A2-2 Schematic A2 (part 1), Mantissa Range assembly 5-11

A2

Figure A2-2 Schematic A2 (part 1), Mantissa Range assembly

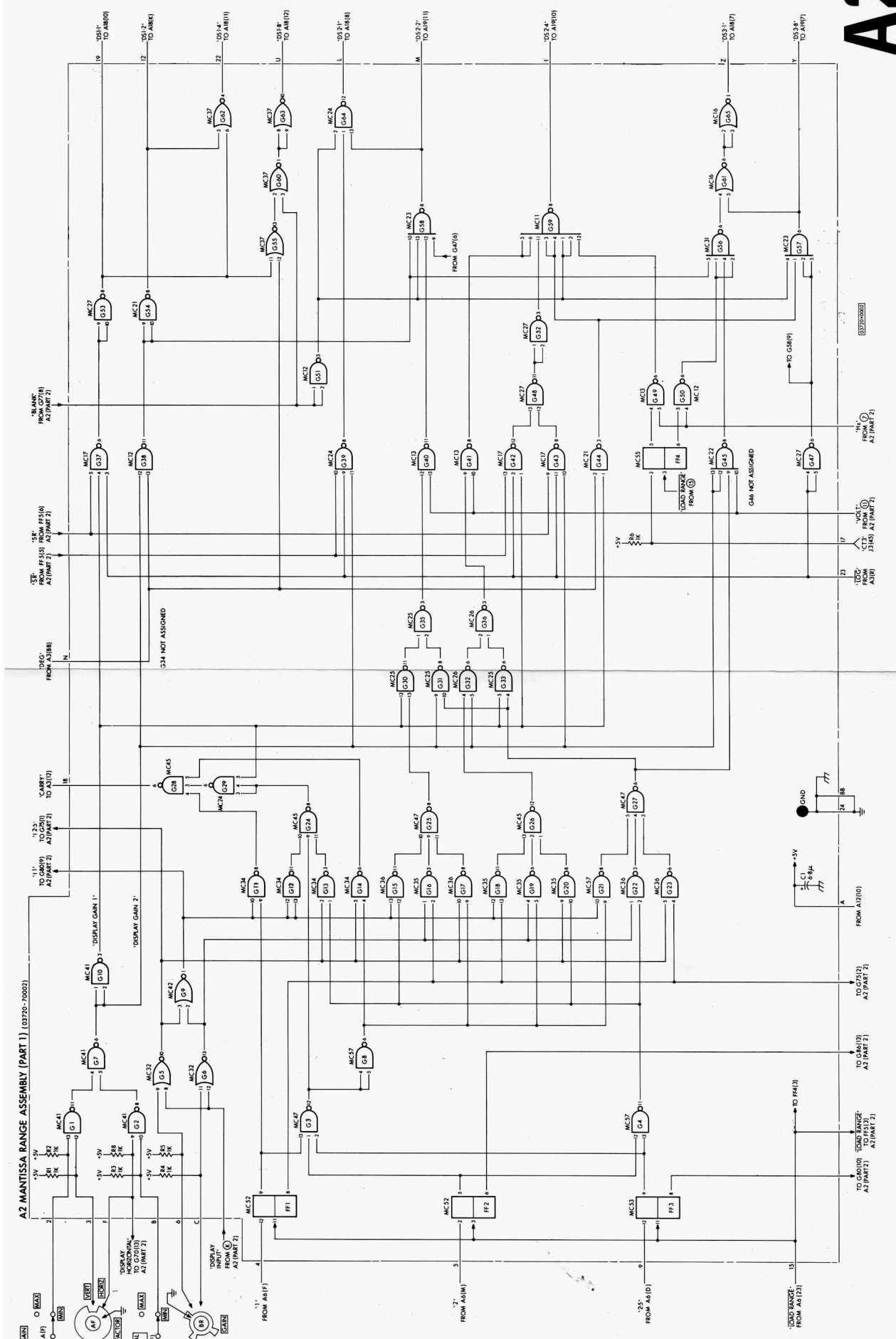

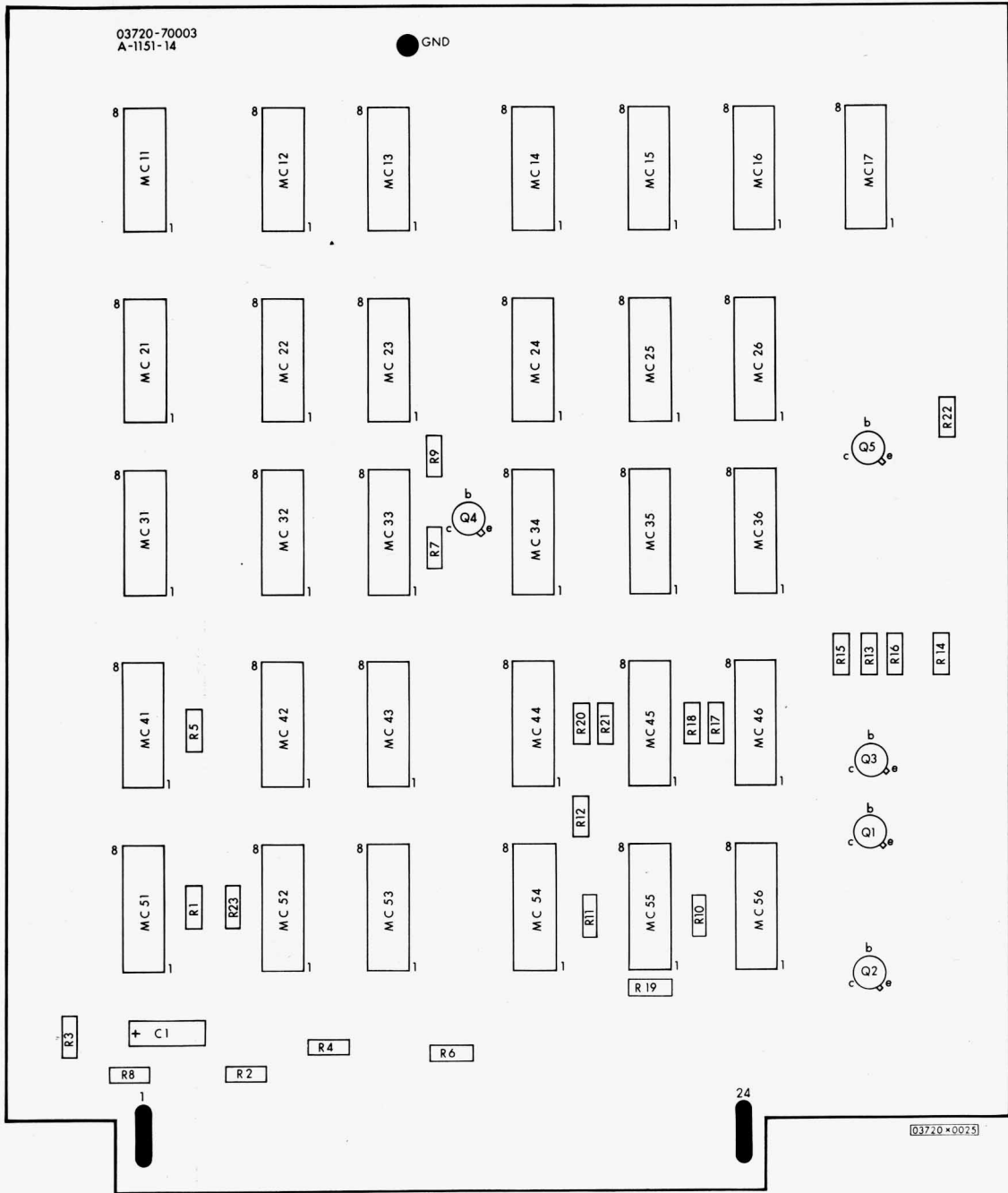
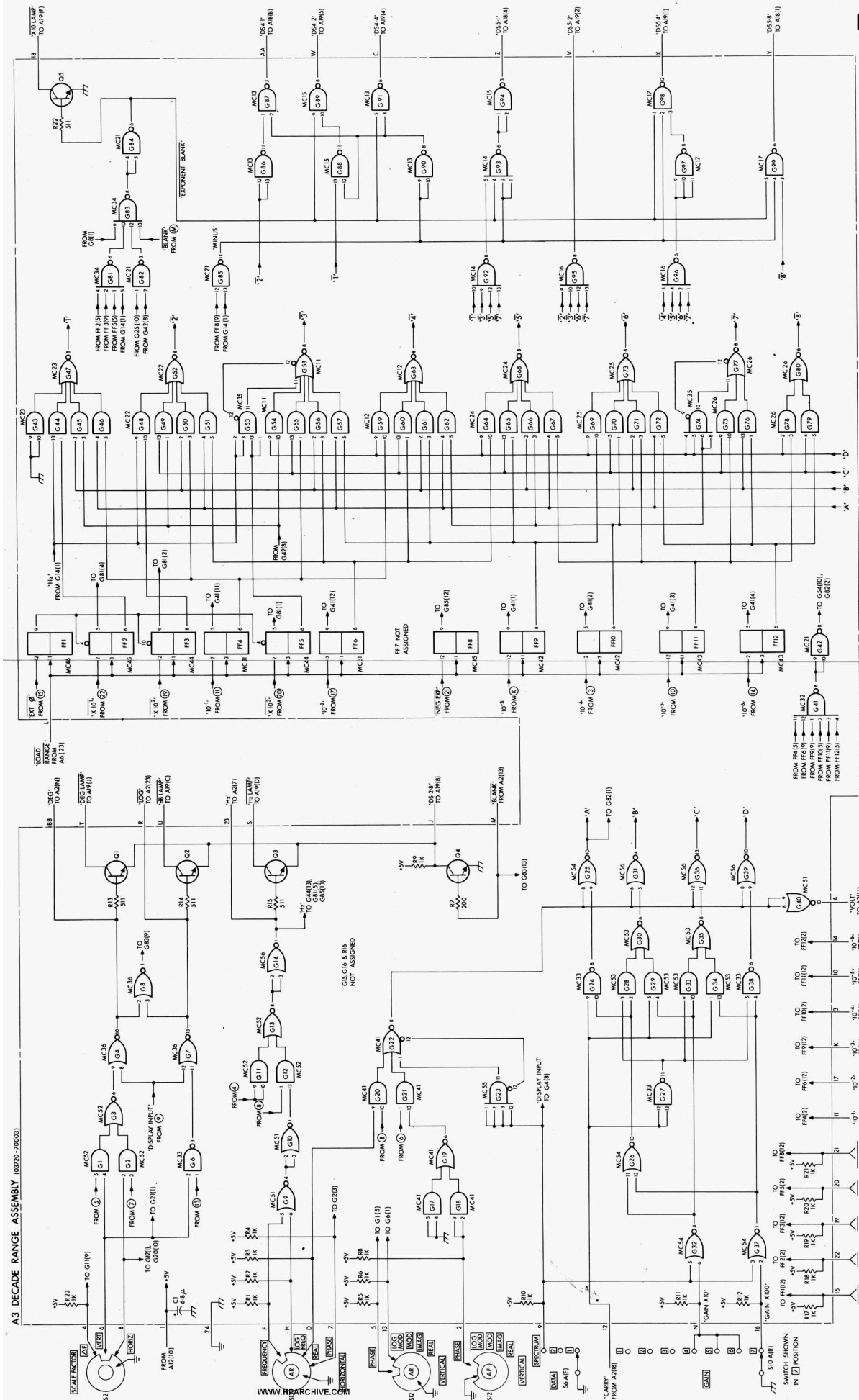

Figure A3-1 Component location, A3



A3

Figure A3-2 Schematic A3, Decade Range assembly

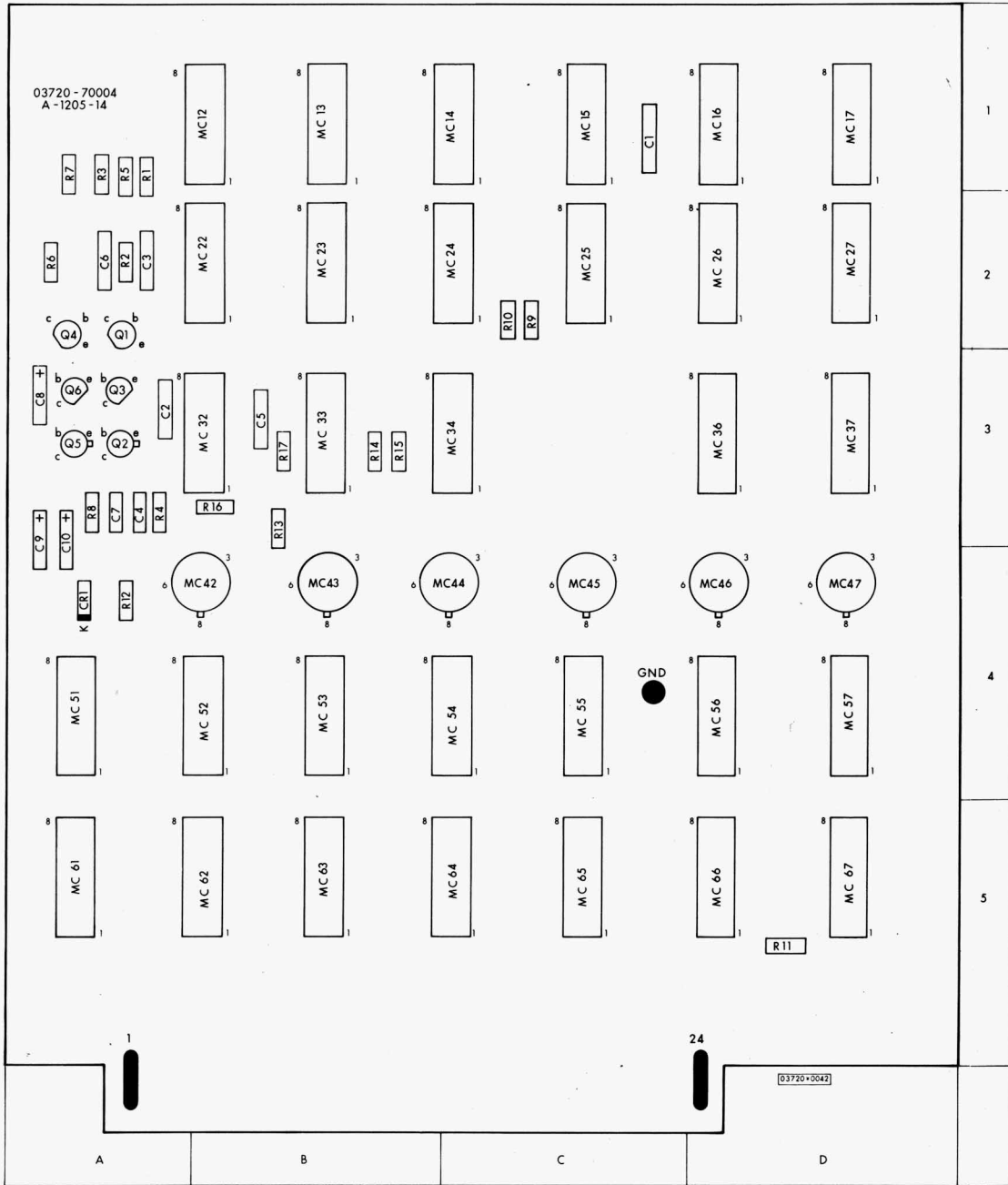
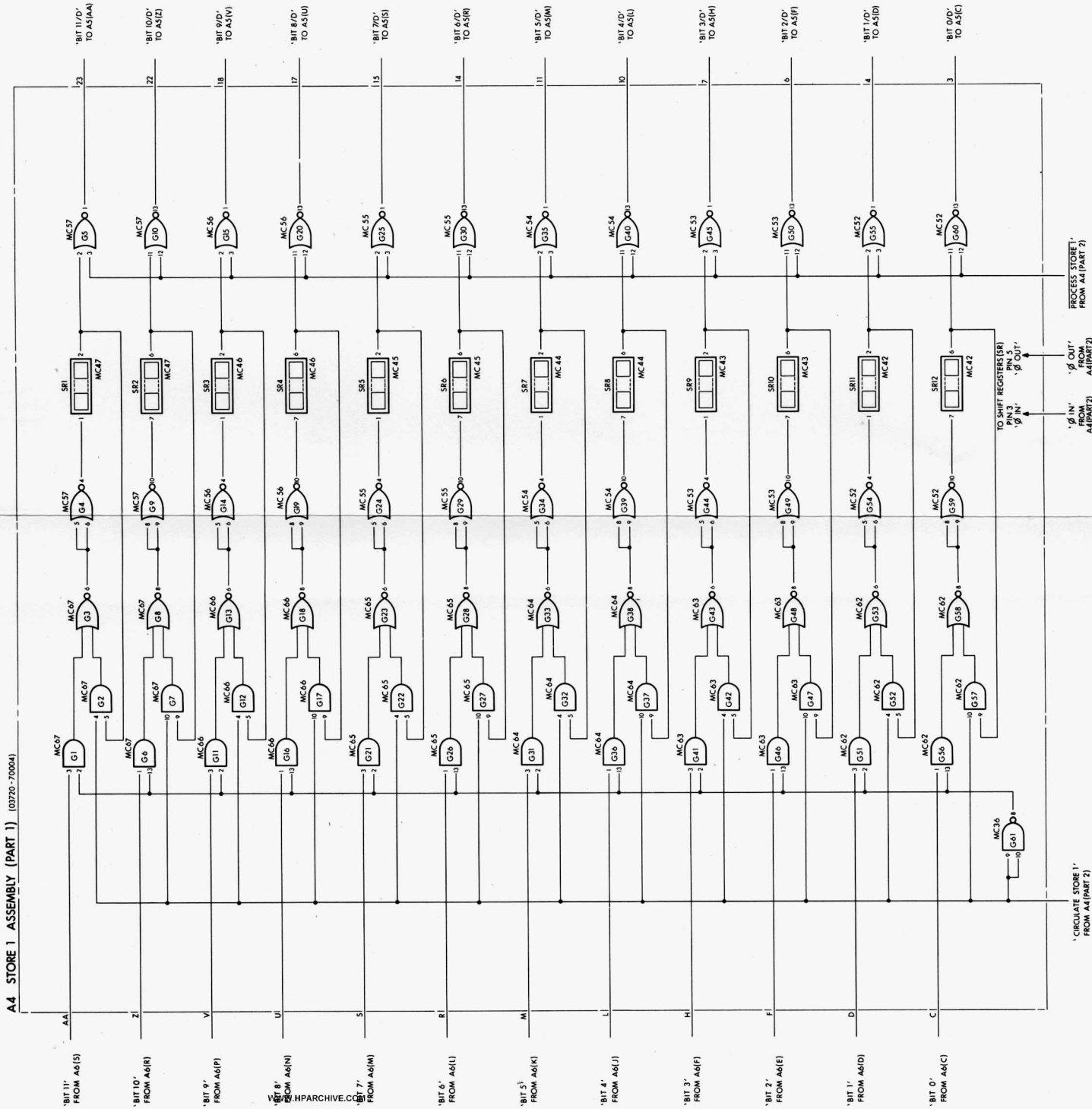

Figure A4-1 Component location, A4



'CIRCULATE STORE 1'
FROM A4(PART 2)

'PROCESS STORE 1'
FROM A4(PART 2)

'OUT'
FROM A4(PART 2)

'IN'
FROM A4(PART 2)

TO SHIFT REGISTERS (SR)
'IN'
'OUT'

'BIT 11/D'
TO A5(AA)

'BIT 10/D'
TO A5(E)

'BIT 9/D'
TO A5(V)

'BIT 8/D'
TO A5(U)

'BIT 7/D'
TO A5(S)

'BIT 6/D'
TO A5(R)

'BIT 5/D'
TO A5(Q)

'BIT 4/D'
TO A5(I)

'BIT 3/D'
TO A5(H)

'BIT 2/D'
TO A5(F)

'BIT 1/D'
TO A5(D)

'BIT 0/D'
TO A5(C)

03720-004

Table A4-1 Component identification grid, A4

C		R	
REF DESIG	GRID LOC	REF DESIG	GRID LOC
C1	C-1	R1	A-1
C2	A-3	R2	A-2
C3	A-2	R3	A-1
C4	A-3	R4	A-3
C5	B-3	R5	A-1
C6	A-2	R6	A-2
C7	A-3	R7	A-1
C8	A-3	R8	A-3
C9	A-3	R9	C-2
C10	A-3	R10	C-2
CR		R11	D-5
REF DESIG	GRID LOC	R12	A-4
CR1	A-4	R13	B-3
		R14	B-3
		R15	B-3
		R16	B-3
		R17	B-3
Q		TP	
REF DESIG	GRID LOC	REF DESIG	GRID LOC
Q1	A-2	GND	C-4
Q2	A-3		
Q3	A-3		
Q4	A-2		
Q5	A-3		
Q6	A-3		

Note: For complete reference designation, prefix reference designators with A4

A4 STORE 1 ASSEMBLY (PART 2) (03720-70004)

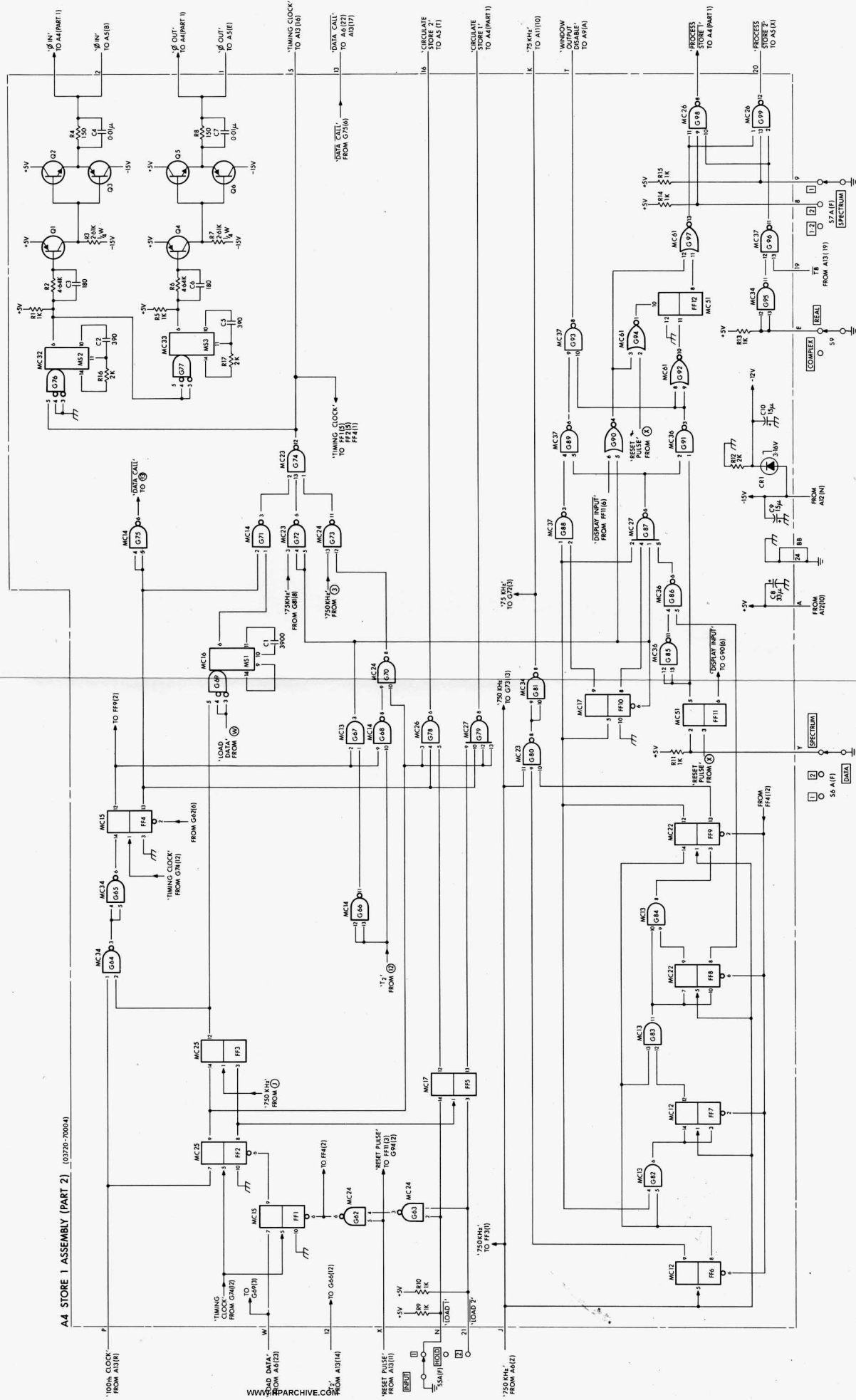

03720-0002

Figure A4-3 Schematic A4 (part 2), Store 1 assembly 5-19

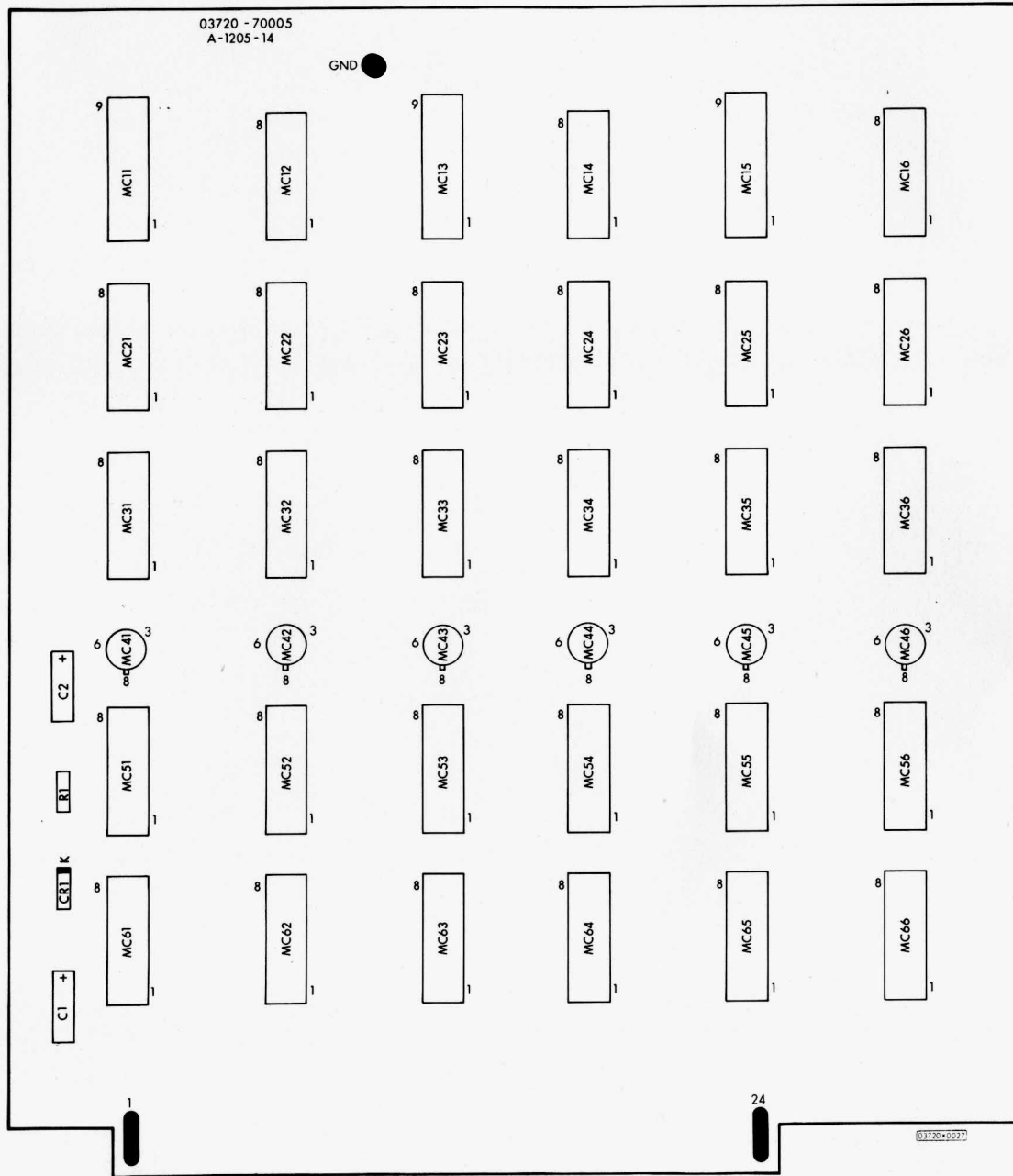
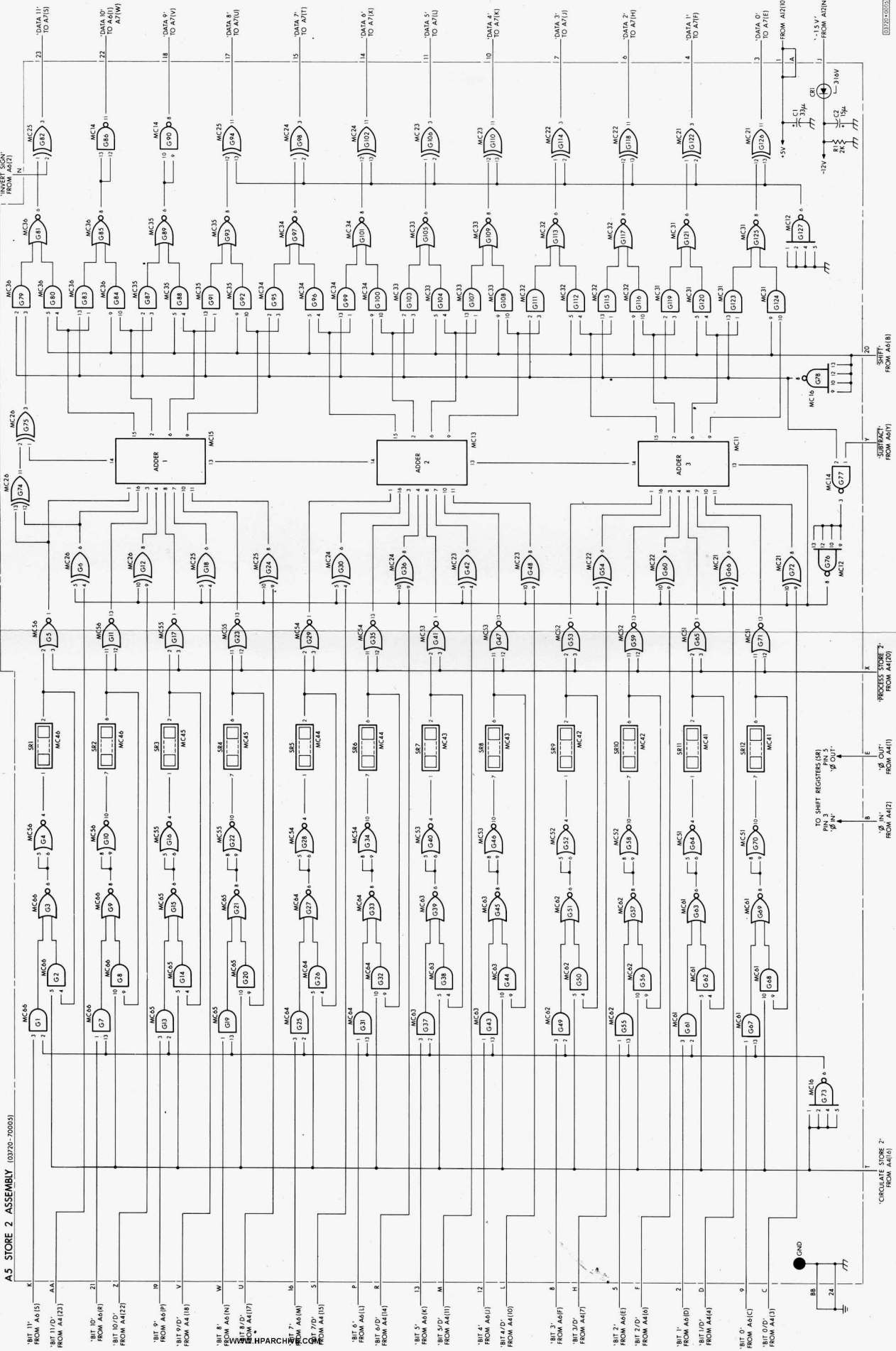

Figure A5-1 Component location, A5



A5

Figure A5-2 Schematic A5, Store 2 assembly

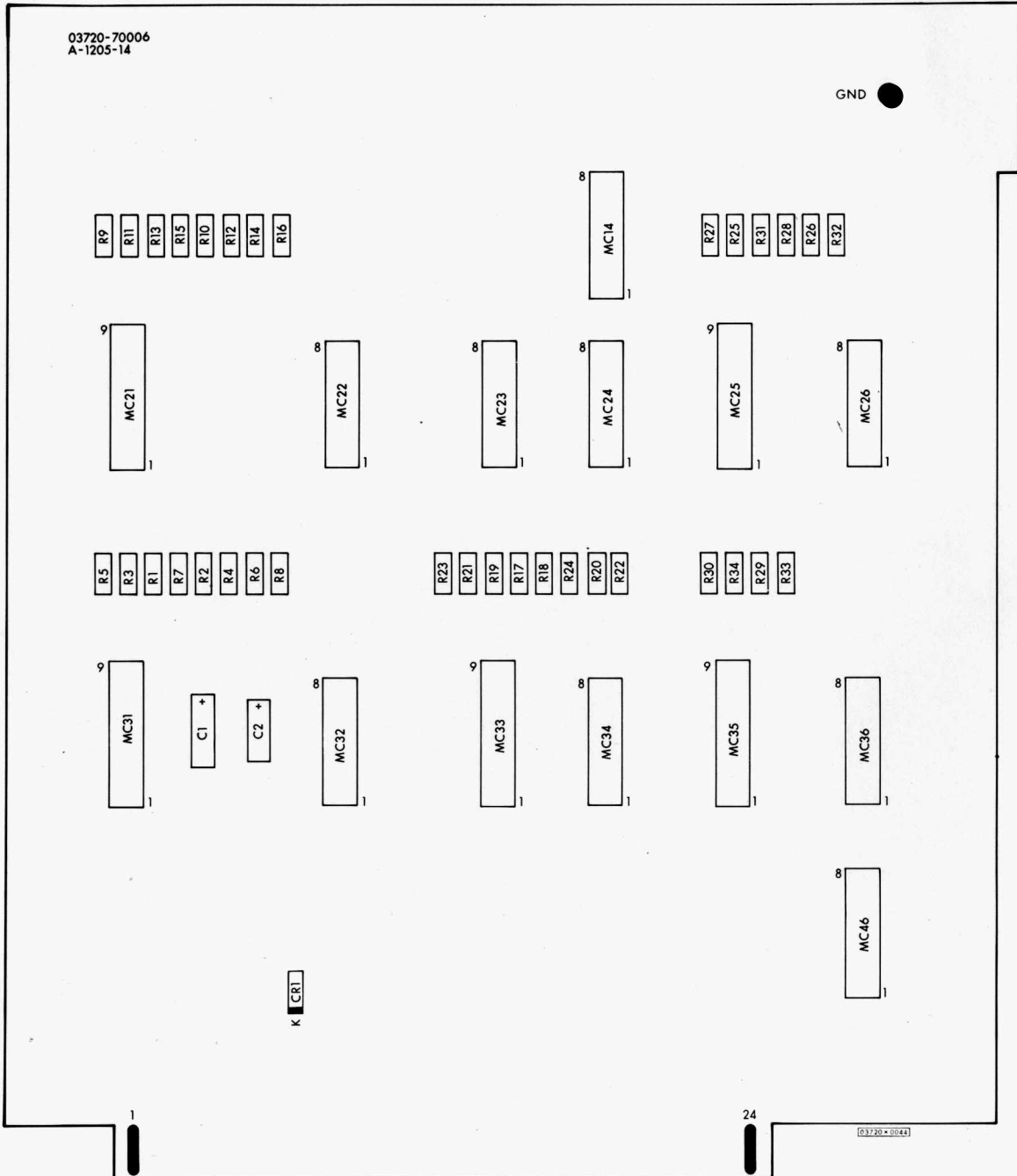
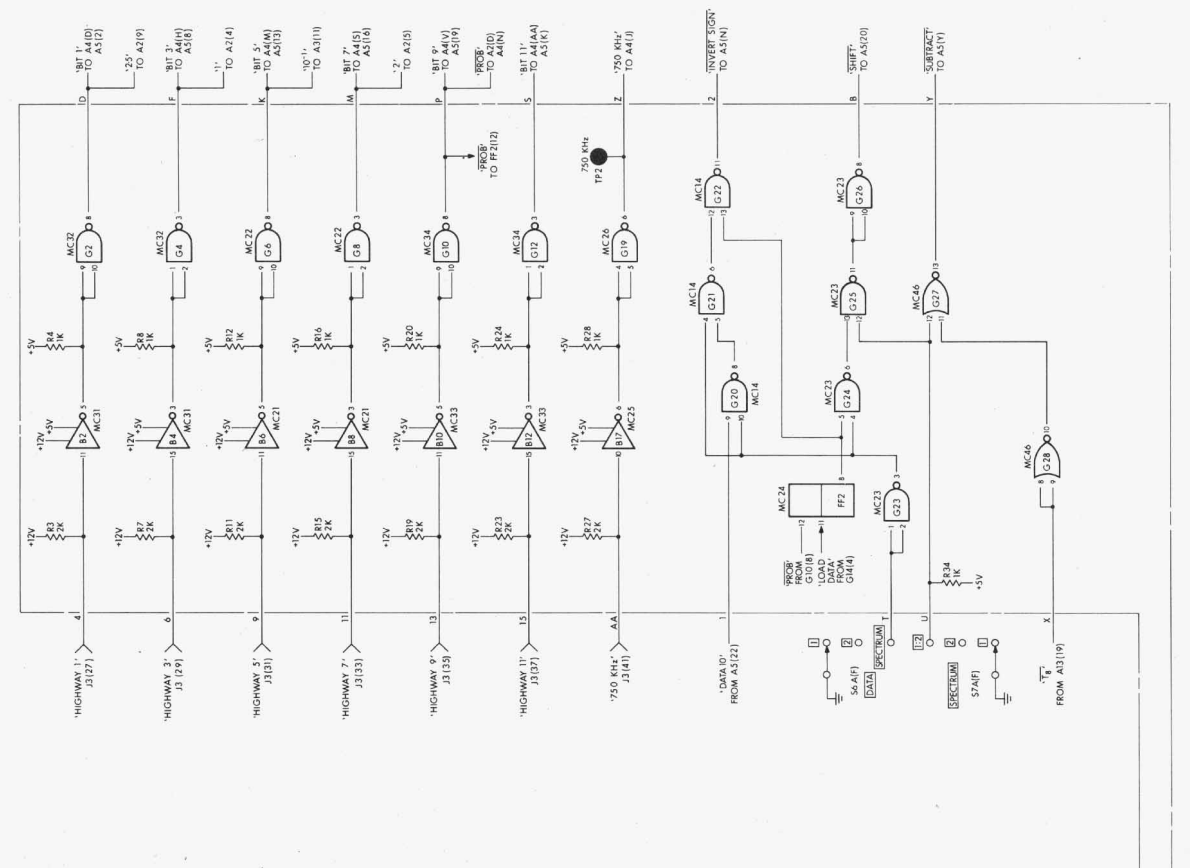
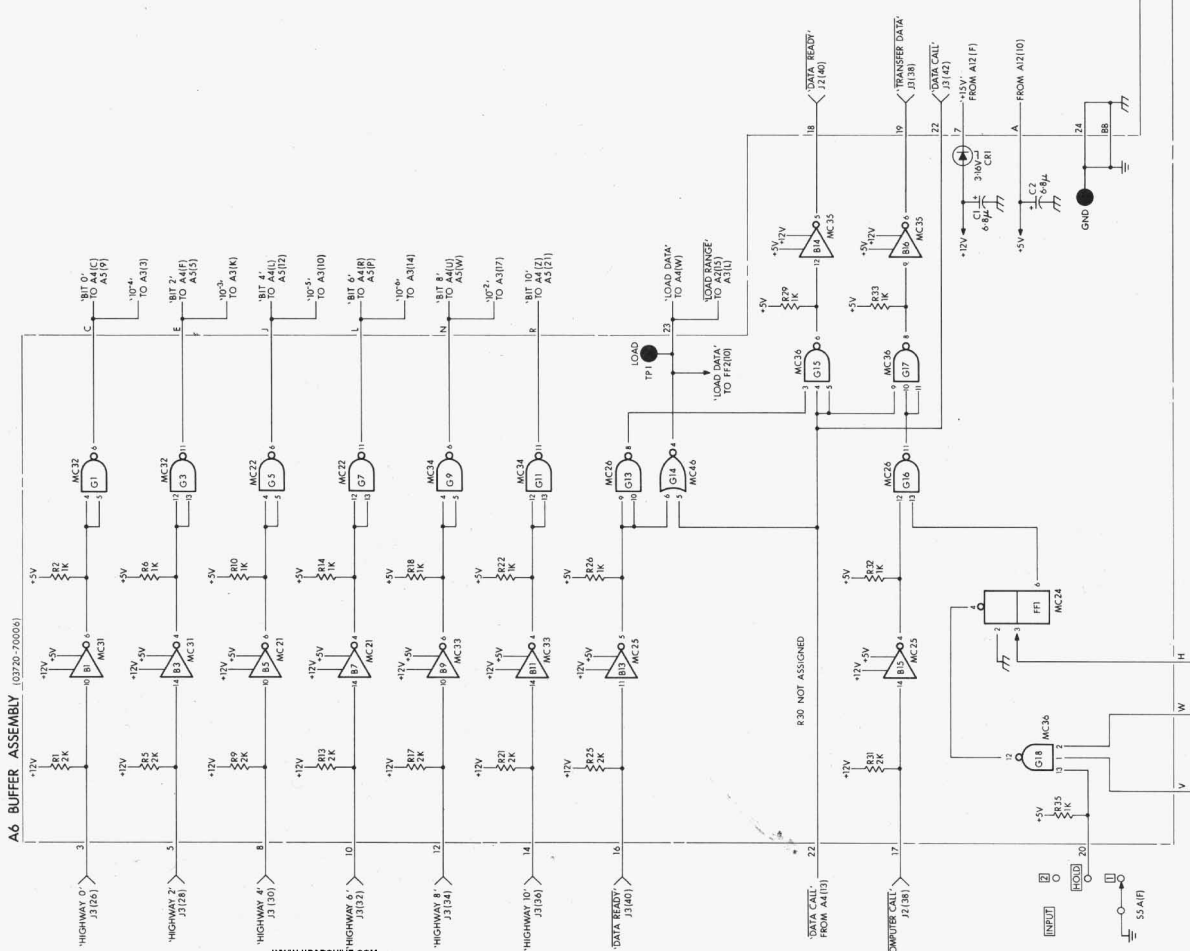

Figure A6-1 Component location, A6

A6 BUFFER ASSEMBLY (0720-20000)



0720-3550

TW0 - TRIANGLE WAVE BIT 0'

TW6 - TRIANGLE WAVE BIT 6'

A6

Figure A6-2 Schematic A6, Buffer assembly

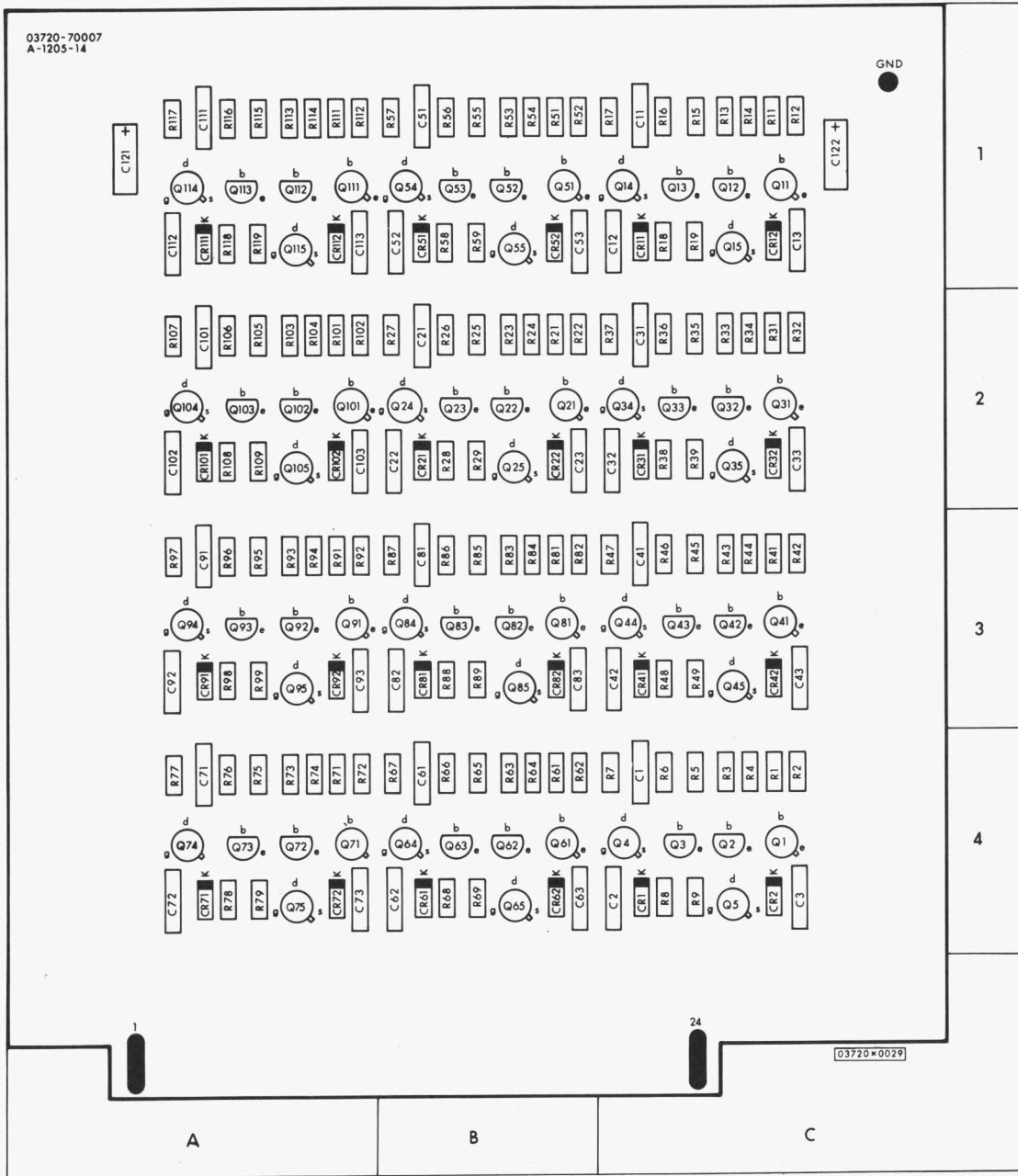
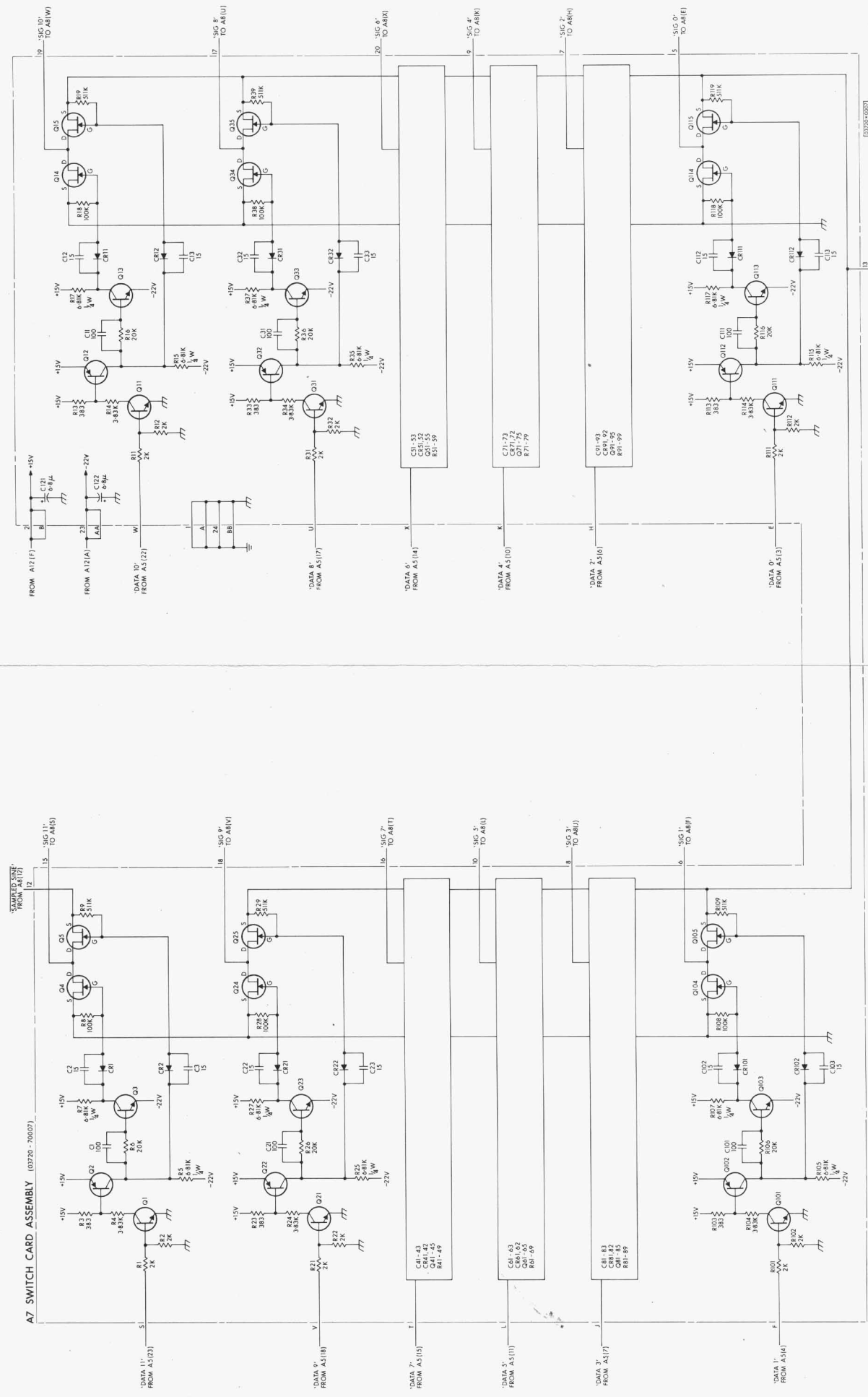

Figure A7-1 Component location, A7



A7

Figure A7-2 Schematic A7, Switch Card assembly

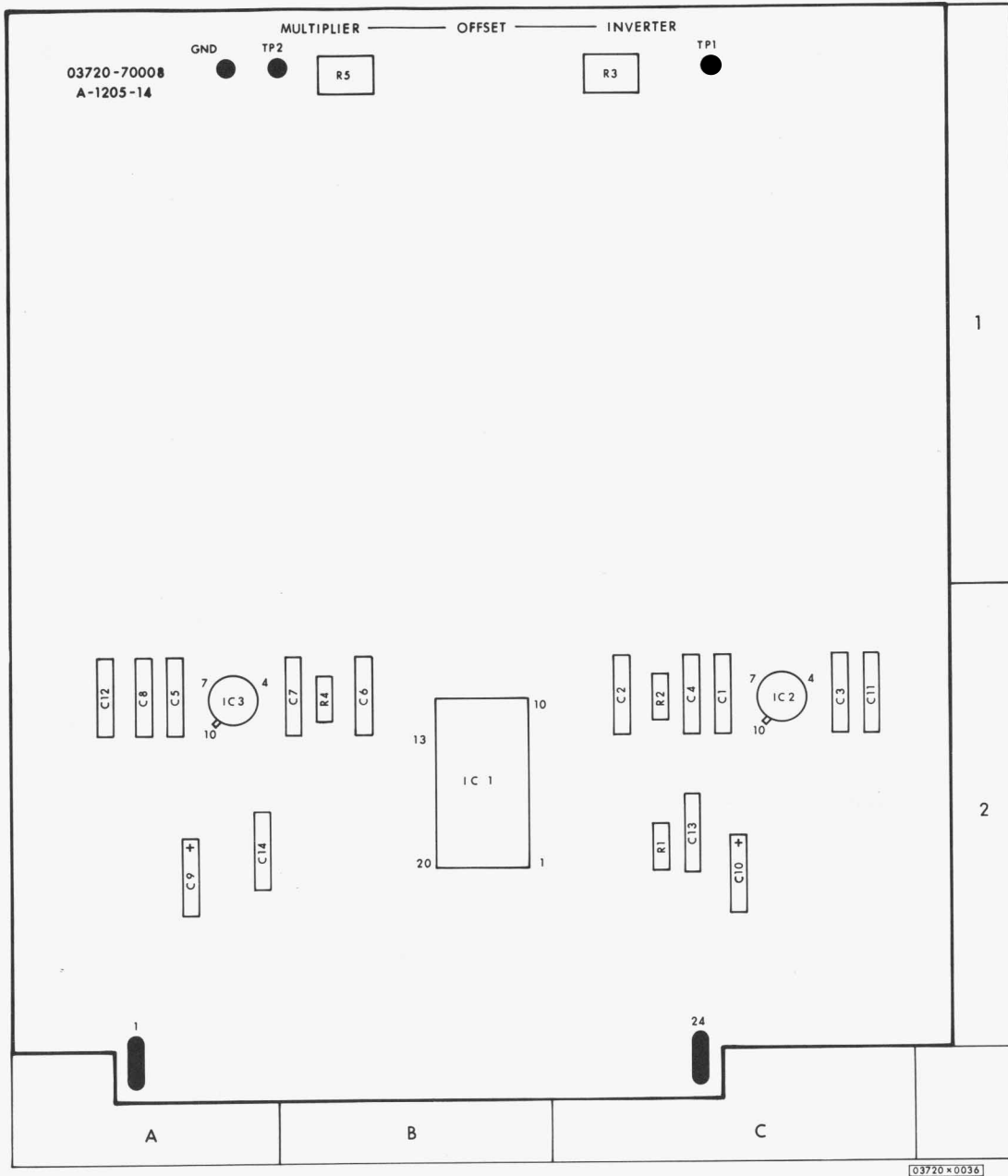
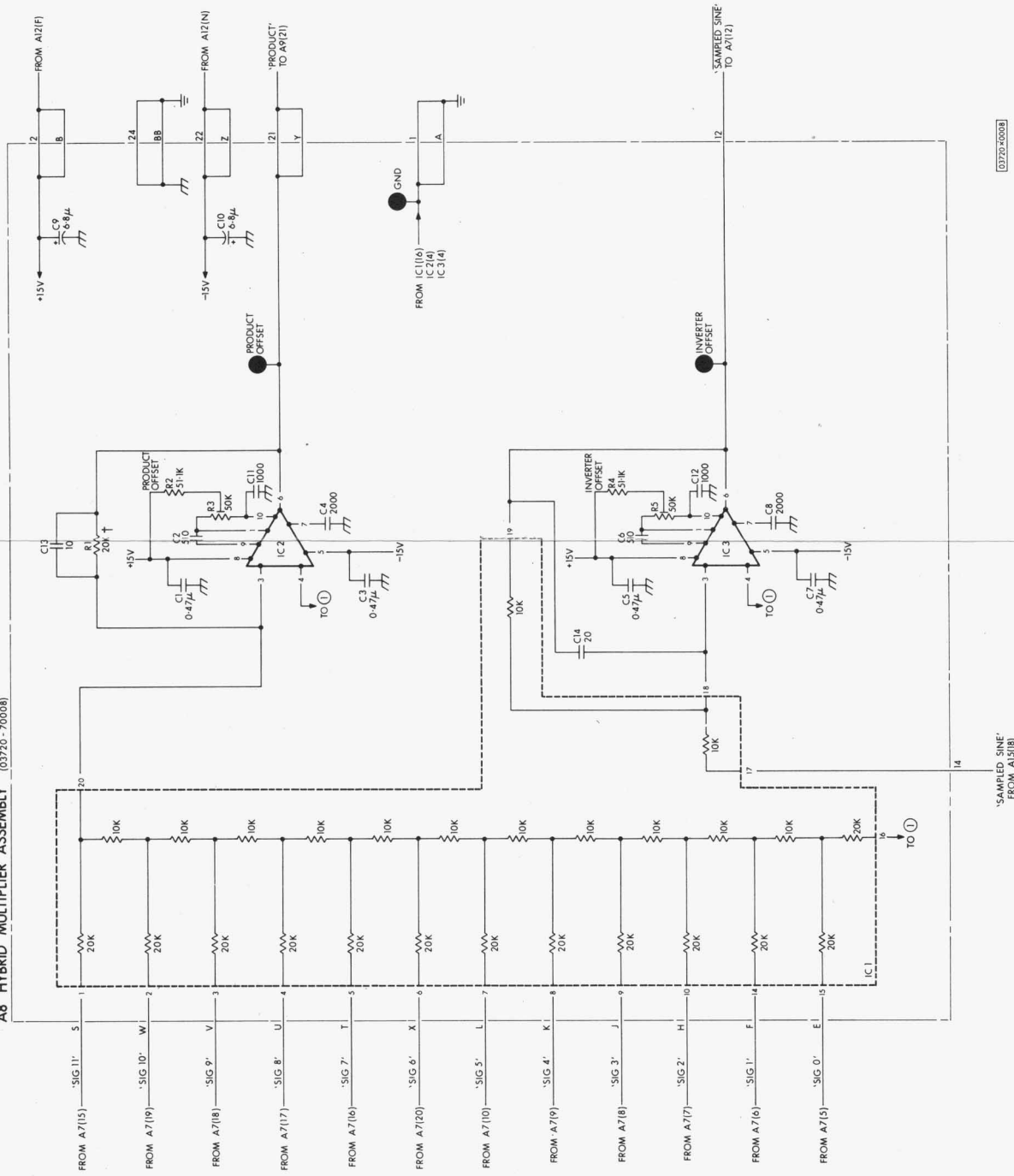

Figure A8-1 Component location, A8

Table A7-1 Component identification grid, A7

C		CR									
REF DESIG	GRID LOC	REF DESIG	GRID LOC								
C1	C-4	CR1	C-4	Q24	B-2	Q114	A-1	R44	C-3	R94	A-1
C2	C-4	CR2	C-4	Q25	B-2	Q115	A-1	R45	C-3	R95	A-1
C3	C-4	CR11	C-1	Q31	C-1	R		R46	C-3	R96	A-1
C11	C-1	CR12	C-1	Q32	C-1			REF DESIG	GRID LOC	R47	C-3
C12	C-1	CR21	B-2	Q33	C-1	R1	C-4	R48	C-3	R98	A-1
C13	C-1	CR22	B-2	Q34	C-1	R2	C-4	R49	C-3	R99	A-1
C21	B-2	CR31	C-2	Q35	C-1	R3	C-4	R51	B-1	A101	A-2
C22	B-2	CR32	C-2	Q41	C-3	R4	C-4	R52	B-1	R102	A-2
C23	B-2	CR41	C-3	Q42	C-3	R5	C-4	R53	B-1	R103	A-2
C31	C-2	CR42	C-3	Q43	C-3	R6	C-4	R54	B-1	R104	A-2
C32	C-2	CR51	B-1	Q44	C-3	R7	C-4	R55	B-1	R105	A-2
C33	C-2	CR52	B-1	Q45	C-3	R8	C-4	R56	B-1	R106	A-2
C41	C-3	CR61	B-4	Q51	B-1	R9	C-4	R58	B-1	R107	A-2
C42	C-3	CR62	B-4	Q52	B-1	R11	C-1	R59	B-1	R108	A-2
C43	C-3	CR71	A-4	Q53	B-1	R12	C-1	R61	B-4	R109	A-2
C51	B-1	CR72	A-4	Q54	B-1	R13	C-1	R62	B-4	R111	A-1
C52	B-1	CR81	B-3	Q55	B-1	R14	C-1	R63	B-4	R112	A-1
C53	B-1	CR82	B-3	Q61	B-4	R15	C-1	R64	B-4	R113	A-1
C61	B-4	CR91	A-3	Q62	B-4	R16	C-1	R65	B-4	R114	A-1
C62	B-4	CR92	A-3	Q63	B-4	R17	C-1	R66	B-4	R115	A-1
C63	B-4	CR111	A-1	Q64	B-4	R18	C-1	R67	B-4	R116	A-1
C71	A-4	CR112	A-1	Q65	B-4	R19	C-1	R68	B-4	R117	A-1
C72	A-4			Q71	A-4	R21	B-2	R69	B-4	R118	A-1
C73	A-4			Q72	A-4	R22	B-2	R71	A-4	R119	A-1
C81	B-3			Q73	A-4	R23	B-2	R72	A-4	TP	
C82	B-3			Q74	A-4	R24	B-2	R73	A-4	REF DESIG	GRID LOC
C83	B-3			Q75	A-4	R25	B-2	R74	A-4	GND	C-1
C91	A-3			Q81	B-3	R26	B-2	R75	A-4		
C92	A-3			Q82	B-3	R27	B-2	R76	A-4		
C93	A-3			Q83	B-3	R28	B-2	R77	A-4		
C101	A-2			Q84	B-3	R29	B-2	R78	A-4		
C102	A-2			Q85	B-3	R31	C-2	R79	A-4		
C103	A-2			Q91	A-3	R32	C-2	R81	B-3		
C111	A-1			Q92	A-3	R33	C-2	R82	B-3		
C112	A-1			Q93	A-3	R34	C-2	R83	B-3		
C113	A-1			Q94	A-3	R35	C-2	R84	B-3		
C121	A-1			Q95	A-3	R36	C-2	R85	B-3		
C122	C-1			Q101	A-2	R37	C-2	R86	B-3		
				Q102	A-2	R38	C-2	R87	B-3		
				Q103	A-2	R39	C-2	R88	B-3		
				Q104	A-2	R41	C-3	R89	B-3		
				Q105	A-2	R42	C-3	R91	A-1		
				Q111	A-1	R43	C-3	R92	A-1		
				Q112	A-1			R93	A-1		
				Q113	A-1						

Note: For complete reference designation, prefix reference designators with A7



03720-0008

A8

Figure A8-2 Schematic A8, Hybrid Multiplier assembly

Table A8-1 Component identification grid, A8

C		IC2	C-2
REF	GRID	IC3	A-2
DESIG	LOC	R	
		REF	GRID
		DESIG	LOC
C1	C-2	R1	C-2
C2	C-2	R2	C-2
C3	C-3	R3	C-1
C4	C-2	R4	B-2
C5	A-2	R5	B-1
C6	B-2	TP	
C7	B-2	REF	GRID
C8	A-2	DESIG	LOC
C9	A-2	TP1	C-1
C10	C-2	TP2	B-1
C11	C-2	GND	A-1
C12	A-2	IC	
C13	C-2	REF	GRID
C14	A-2	DESIG	LOC
		IC1	B-2

Note: For complete reference designation, prefix reference designators with A8

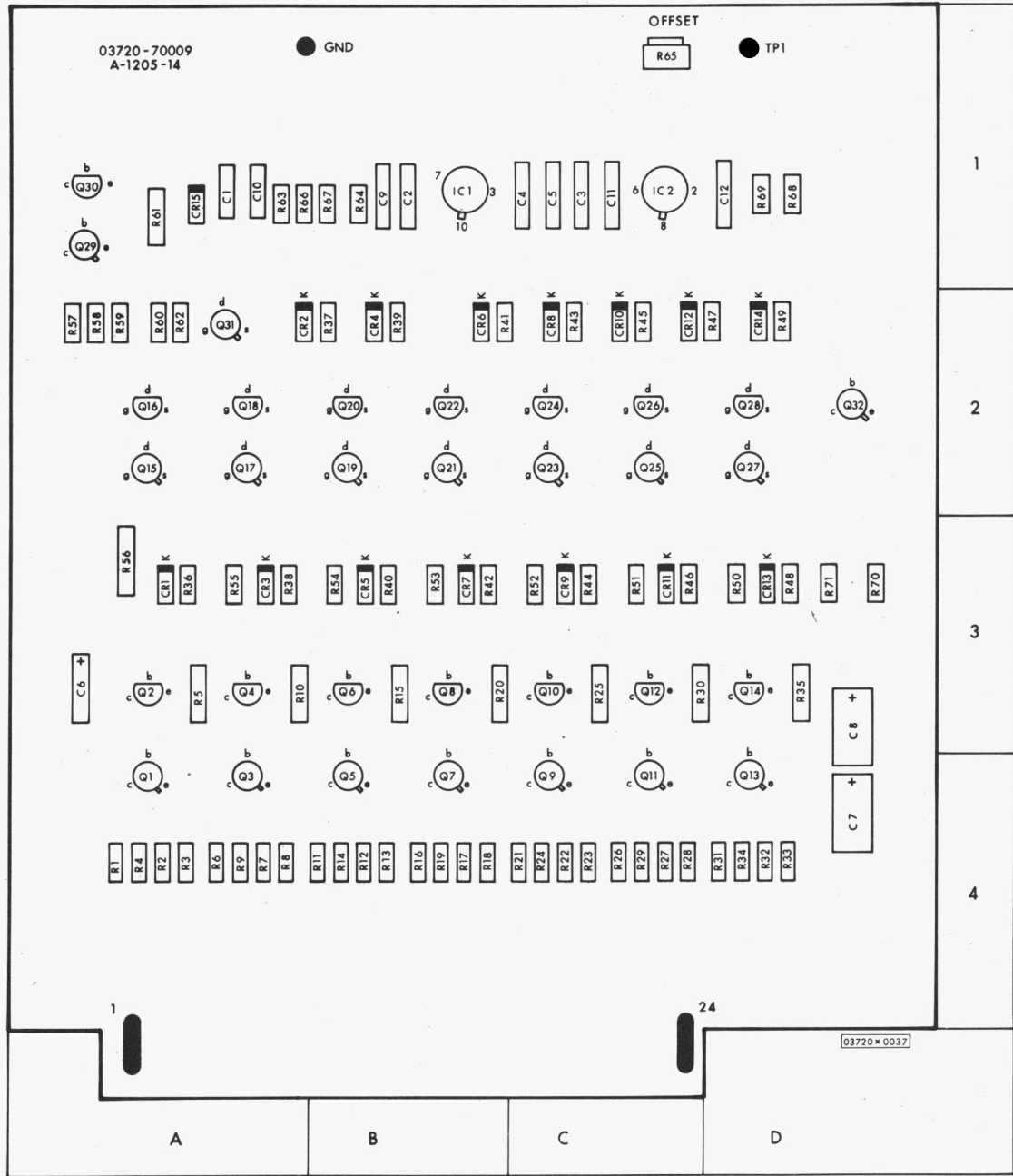

Figure A9-1 Component location, A9

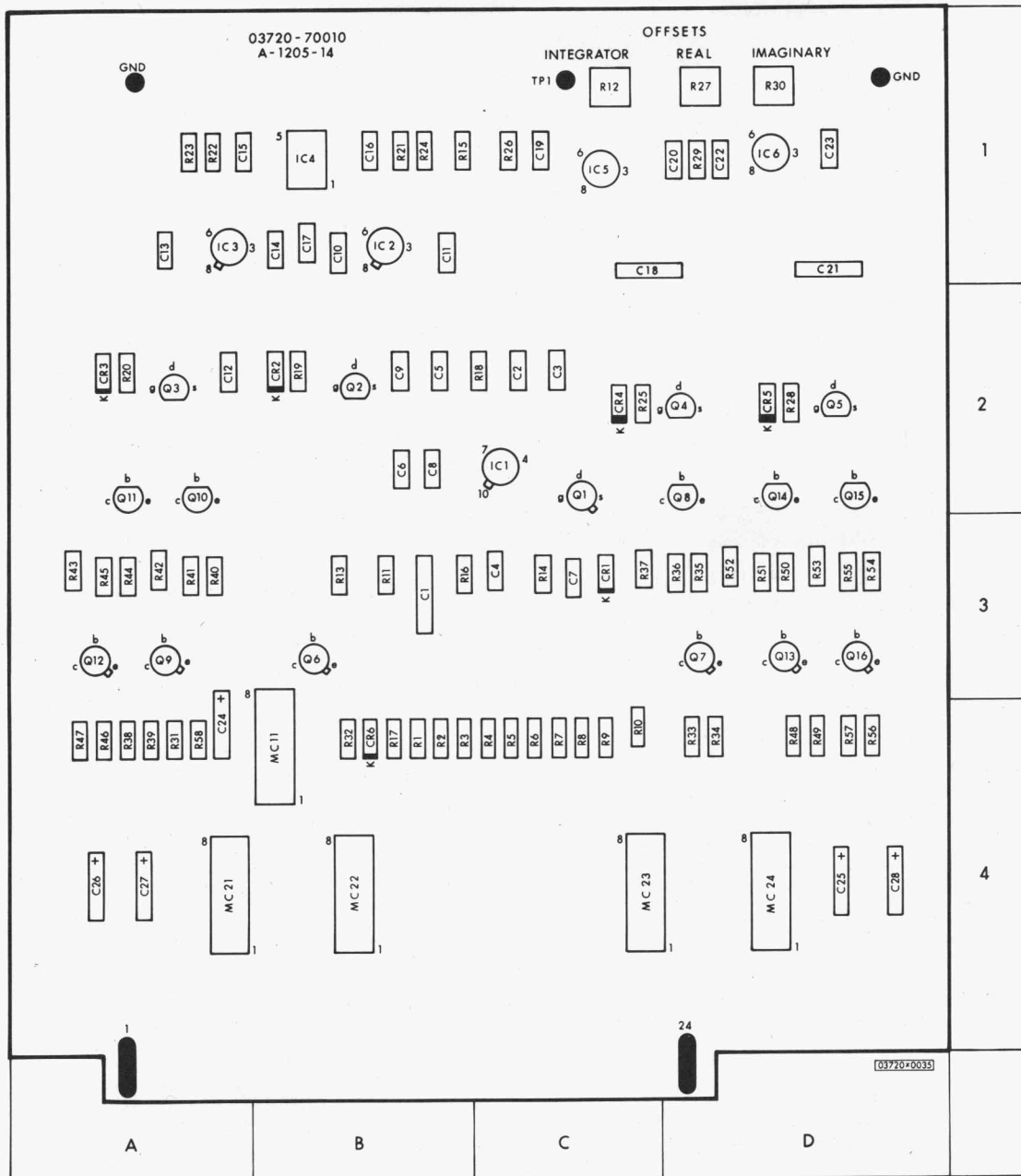
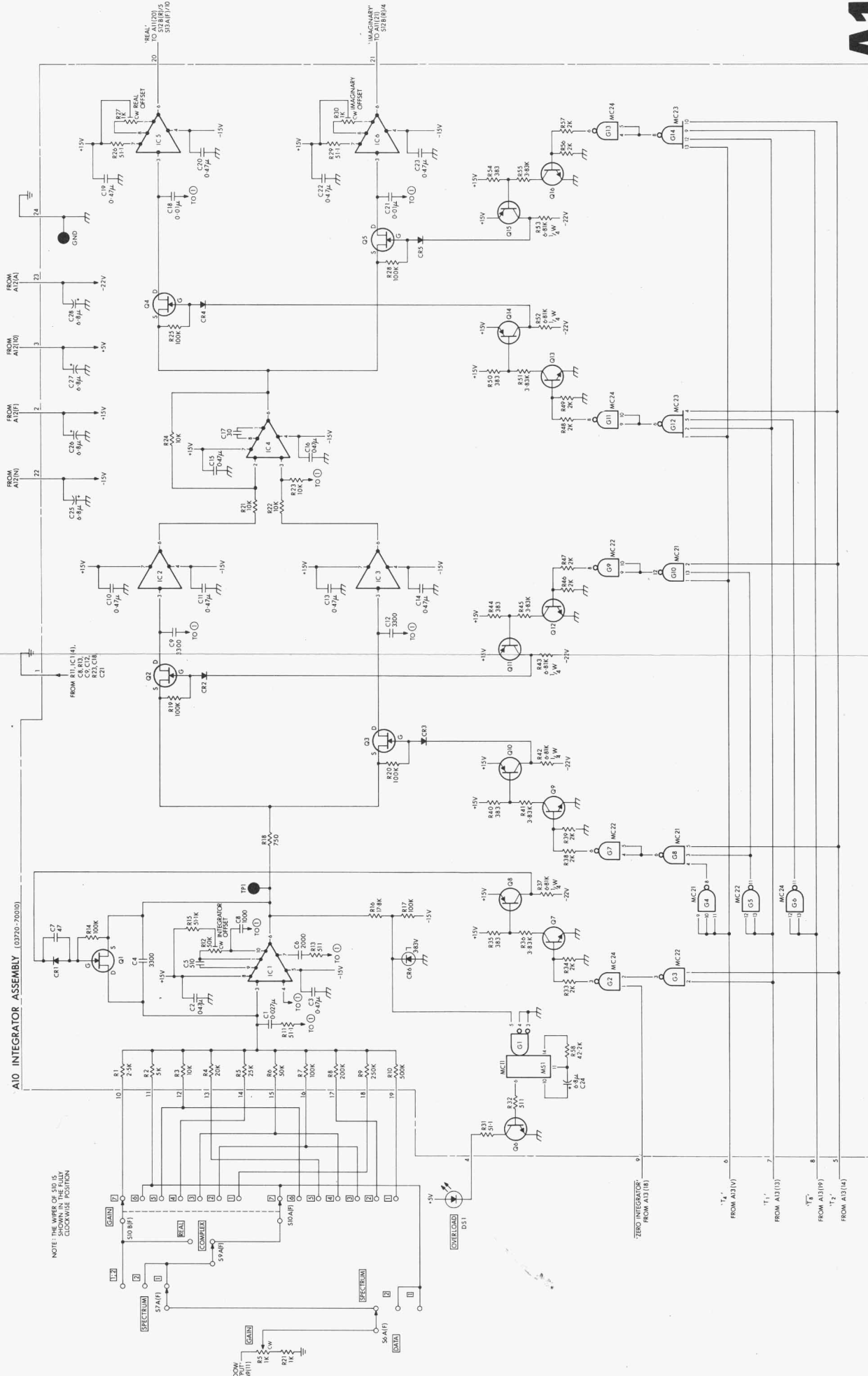

Figure A10-1 Component location, A10



NOTE: THE NUMBER OF 50 IS SHOWN IN THE FULLY CLOCKWISE POSITION

A10

Figure A10-2 Schematic A10, Integrator assembly

Table A10-1 Component identification grid, A10

C		CR					
REF DESIG	GRID LOC	REF DESIG	GRID LOC				
C1	B-3	CR1	C-3	Q13	D-3	R28	D-2
C2	C-2	CR2	B-2	Q14	D-2	R29	D-1
C3	C-2	CR3	A-2	Q15	D-2	R30	D-1
C4	C-3	CR4	C-2	Q16	D-3	R31	A-4
C5	B-2	CR5	D-2	R		R32	B-4
C6	B-2	CR6	B-4			R33	D-4
C7	C-3	IC		REF	GRID	R34	D-4
C8	B-2			DESIG	LOC	R35	D-3
C9	B-2	REF DESIG	GRID LOC	R1	B-4	R36	D-3
C10	B-1	IC1	C-2	R2	B-4	R37	C-3
C11	B-1	IC2	B-1	R3	B-4	R38	A-4
C12	A-2	IC3	A-1	R4	C-4	R39	A-4
C13	A-1	IC4	B-1	R5	C-4	R40	A-3
C14	B-1	IC5	C-1	R6	C-4	R41	A-3
C15	A-1	IC6	D-1	R7	C-4	R42	A-3
C16	B-1	Q		R8	C-4	R43	A-3
C17	B-1			R9	C-4	R44	A-3
C18	C-1	REF DESIG	GRID LOC	R10	C-4	R45	A-3
C19	C-1	Q1	C-2	R11	B-3	R46	A-4
C20	D-1	Q2	B-2	R12	C-1	R47	A-4
C21	D-1	Q3	A-2	R13	B-3	R48	D-4
C22	D-1	Q4	D-2	R14	C-3	R49	D-4
C23	D-1	Q5	D-2	R15	B-1	R50	D-3
C24	A-4	Q6	B-3	R16	B-3	R51	D-3
C25	D-4	Q7	D-3	R17	B-4	R52	D-3
C26	A-4	Q8	D-2	R18	C-2	R53	D-3
C27	A-4	Q9	A-3	R19	B-2	R54	D-3
C28	D-4	Q10	A-2	R20	A-2	R55	D-3
		Q11	A-2	R21	B-1	R56	D-4
		Q12	A-3	R22	A-1	R57	D-4
				R23	A-1	R58	A-4
				R24	B-1	TP	
				R25	C-2	REF DESIG	GRID LOC
				R26	C-1	TP1	C-1
				R27	D-1	GND	A-1
						GND	D-1

Note: For complete reference designation, prefix reference designators with A10

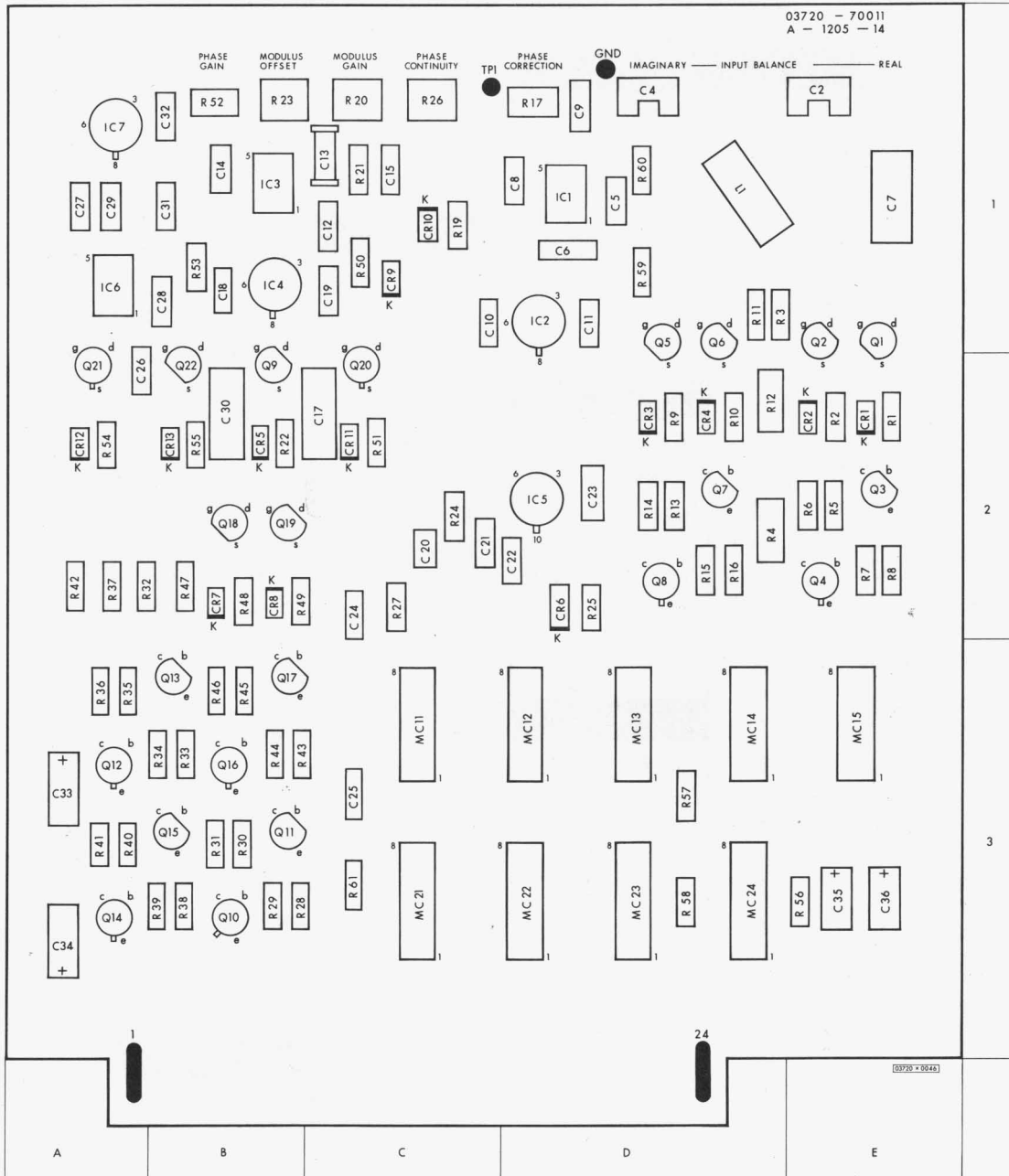
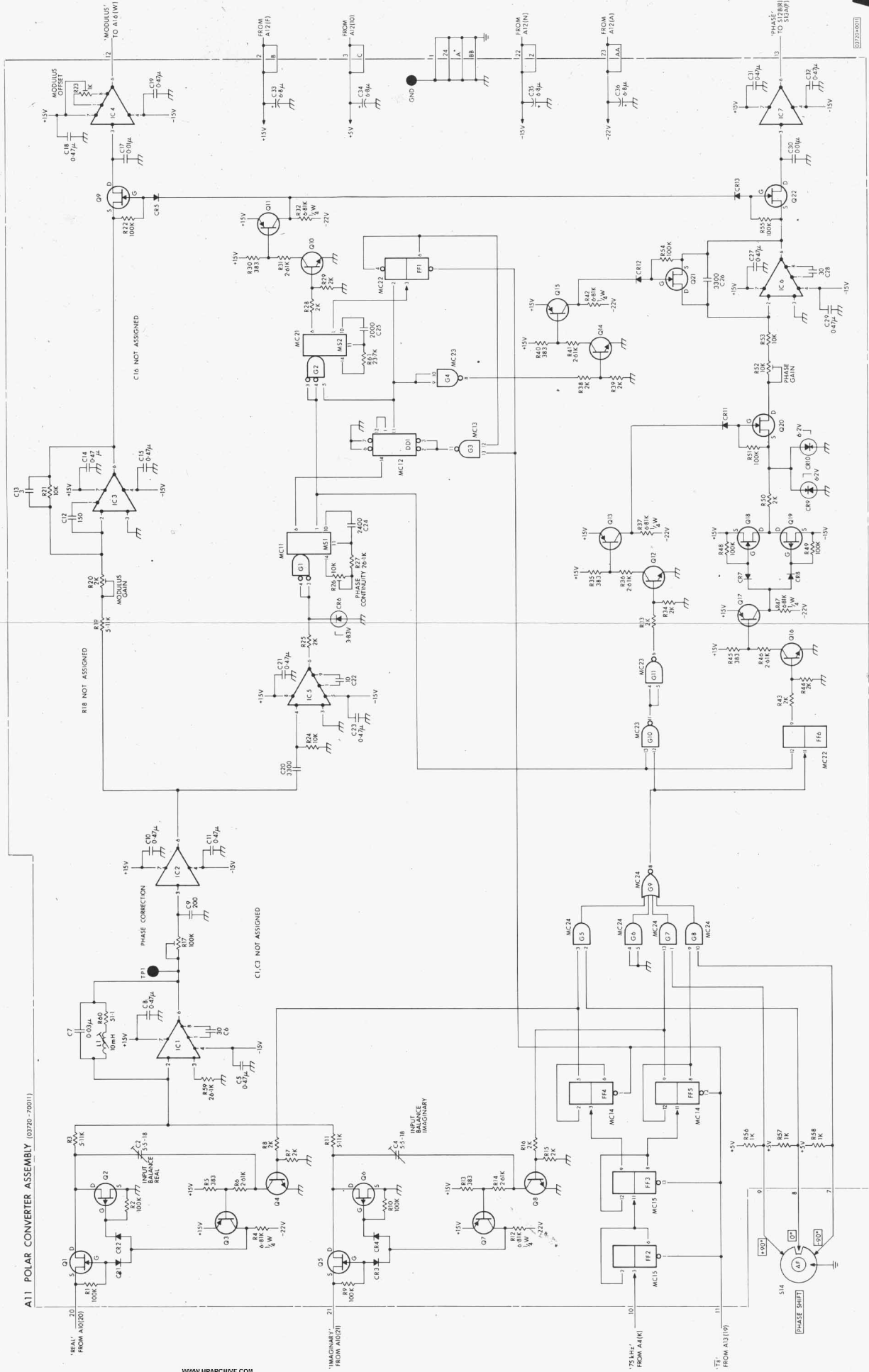

Figure A11-1 Component location, A11

A11 POLAR CONVERTER ASSEMBLY (0720-700011)



A11

Figure A11-2 Schematic A11, Polar Converter assembly 5-33

CHASSIS MOUNTED TRANSISTORS

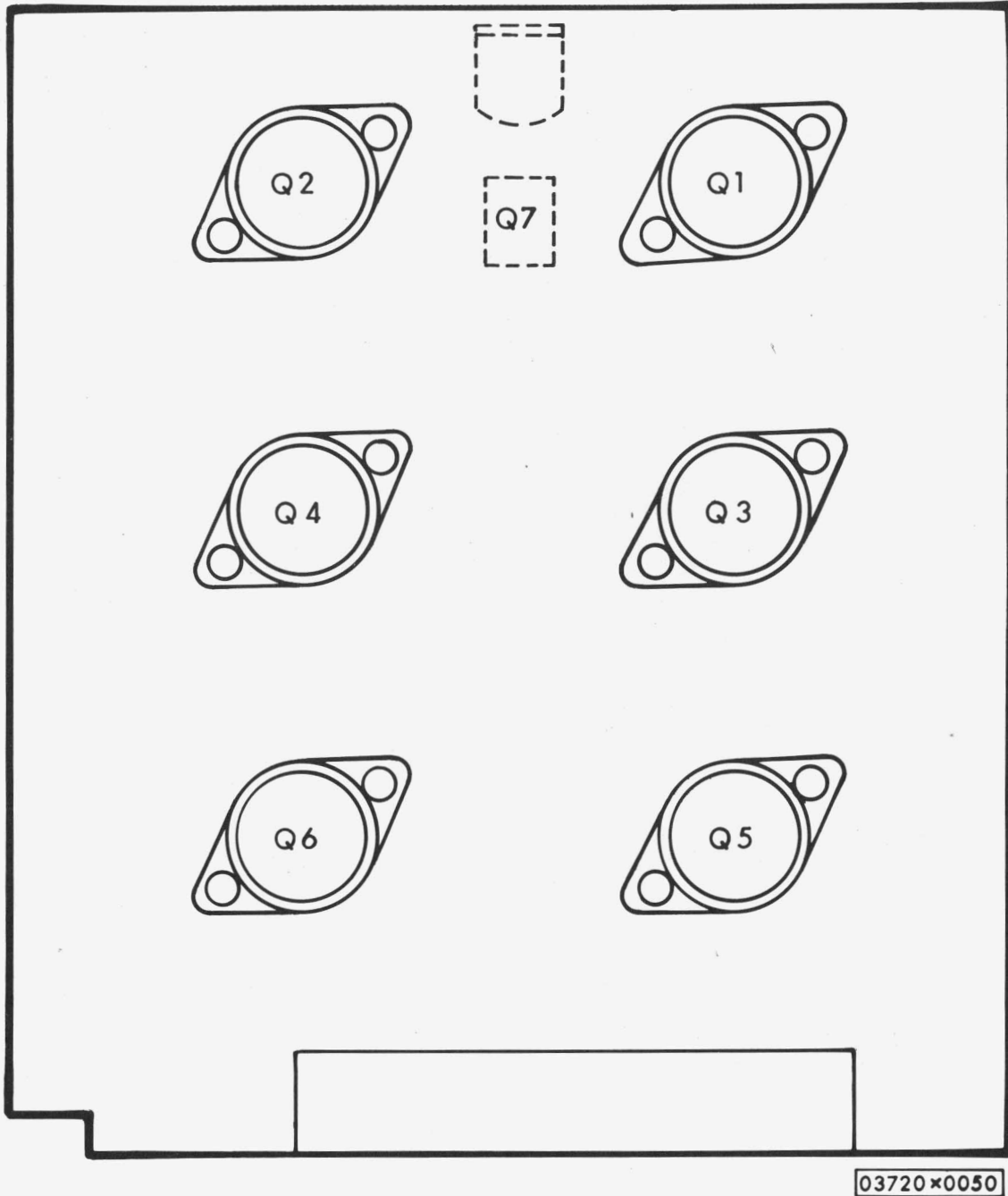
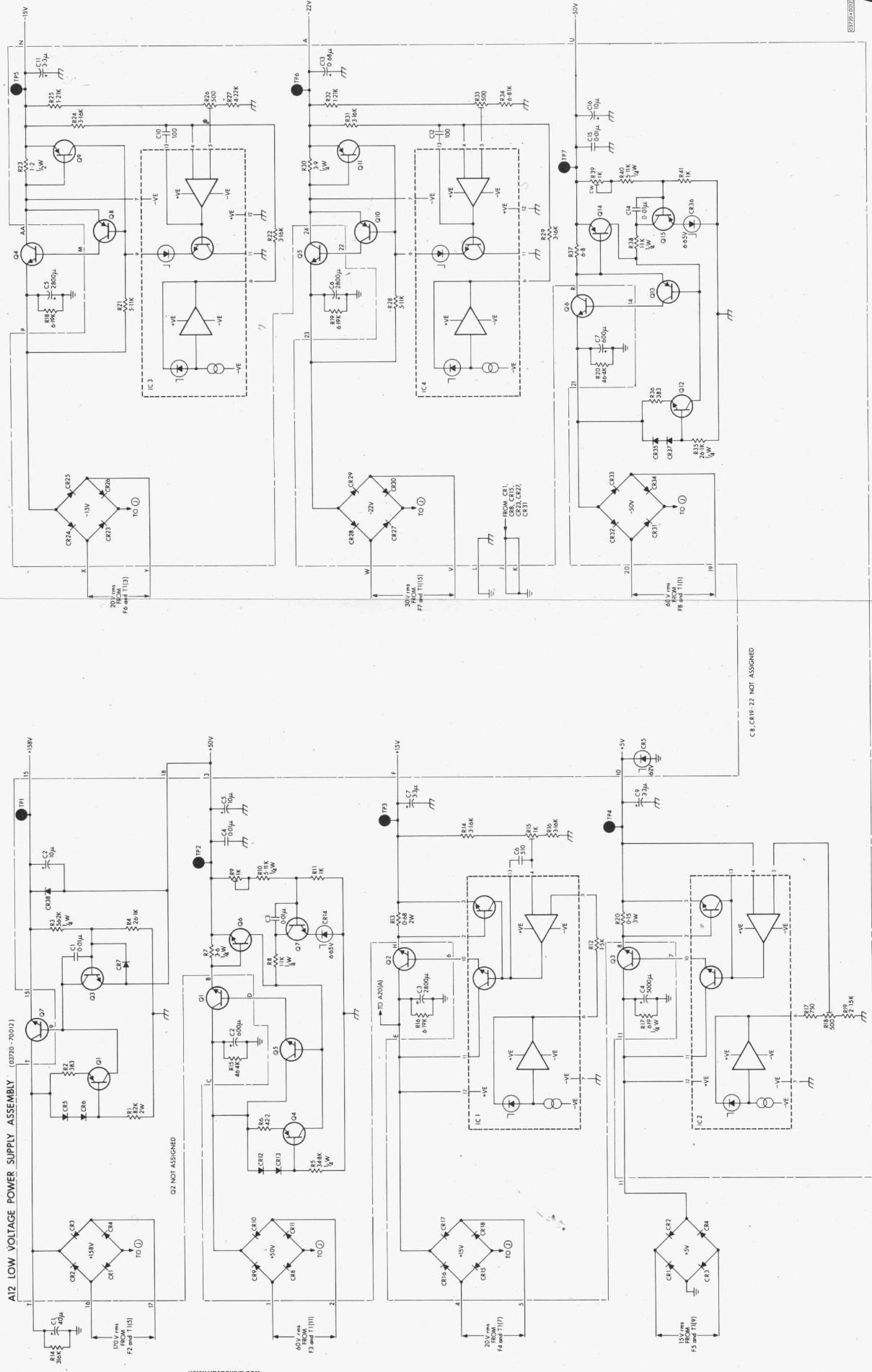

Figure A12-1 Component location, Chassis Mounted Transistors

077-0000

A12

Figure A12-4 Schematic A12, Low Voltage Power Supply assembly



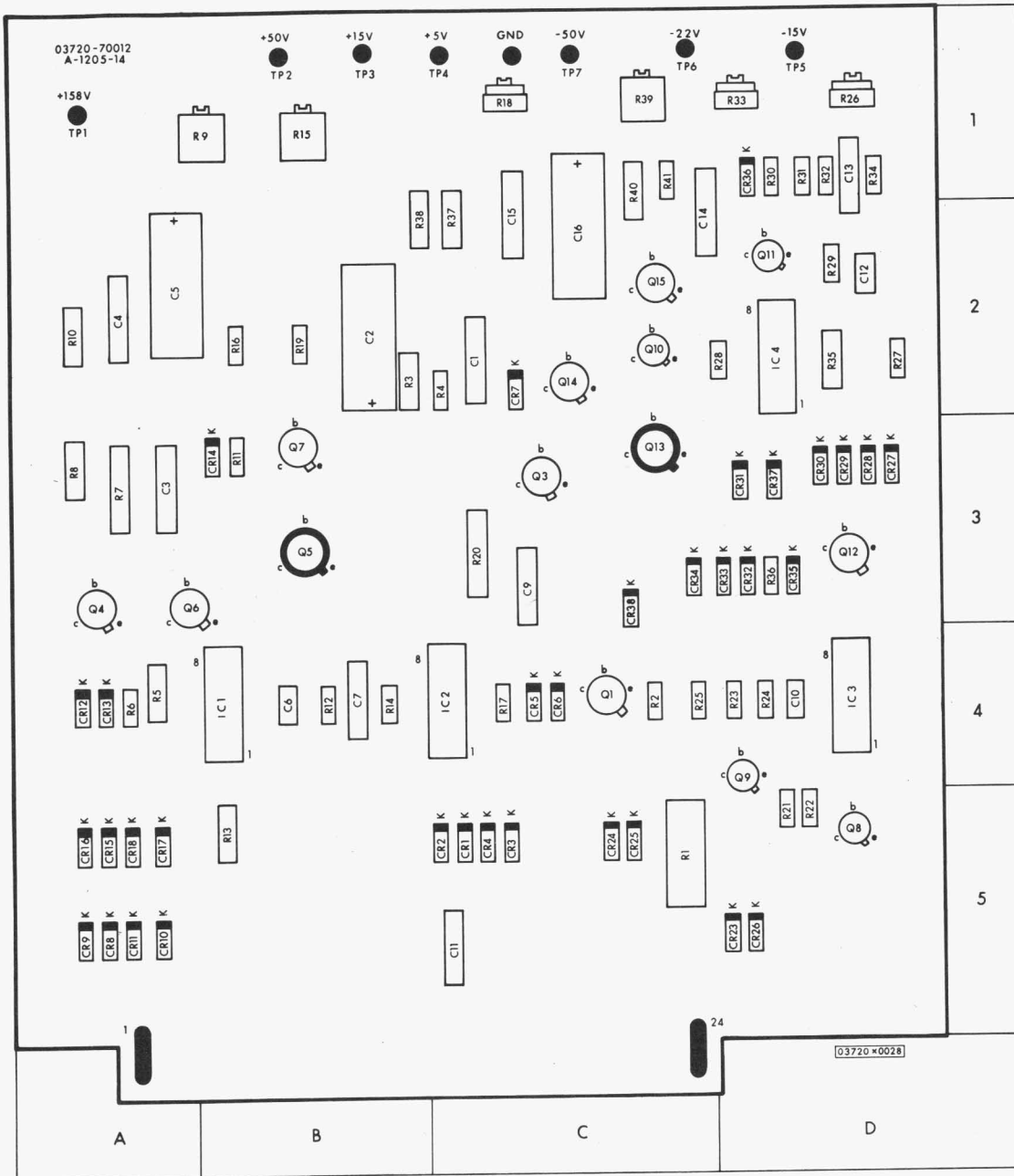
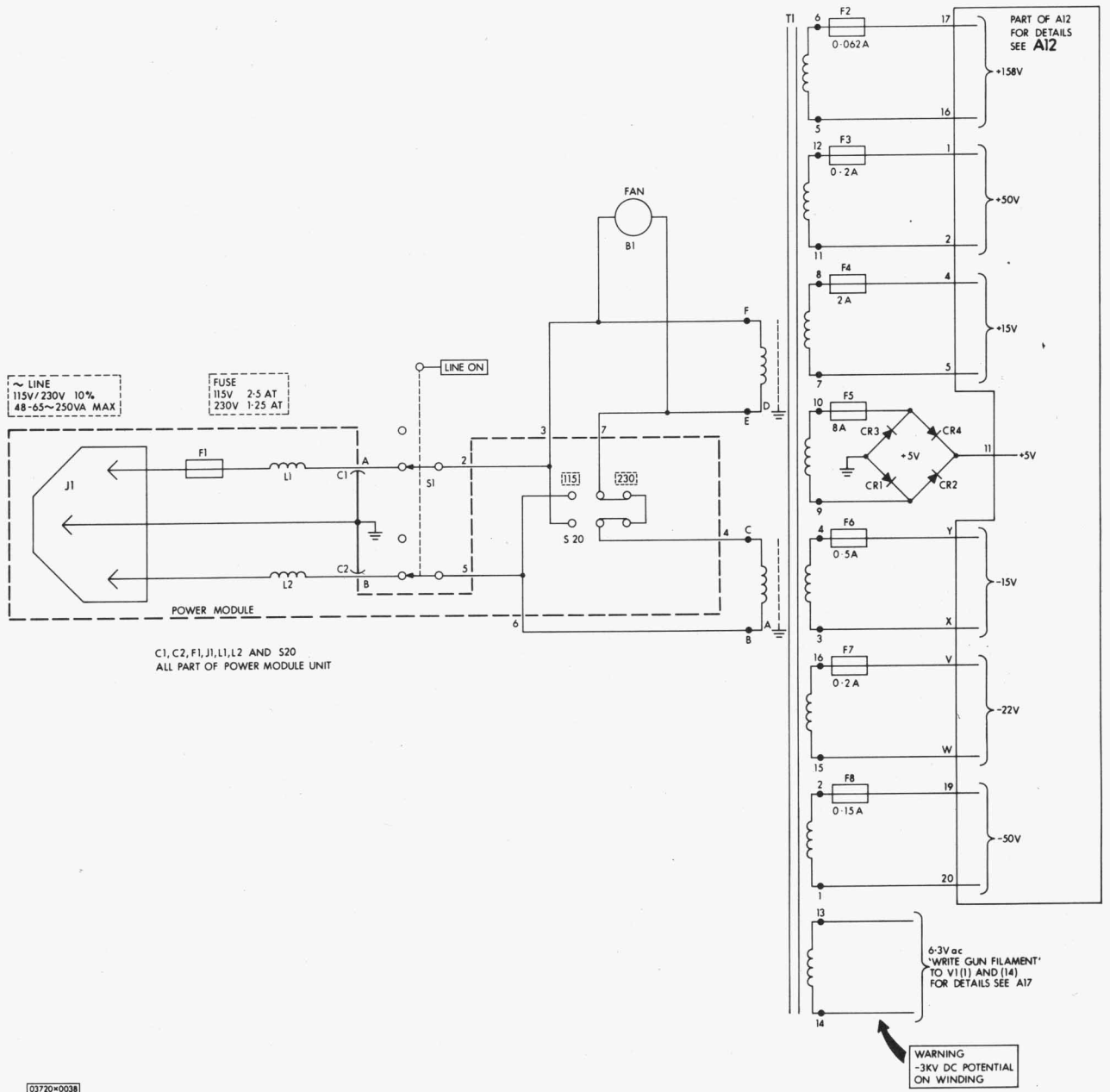
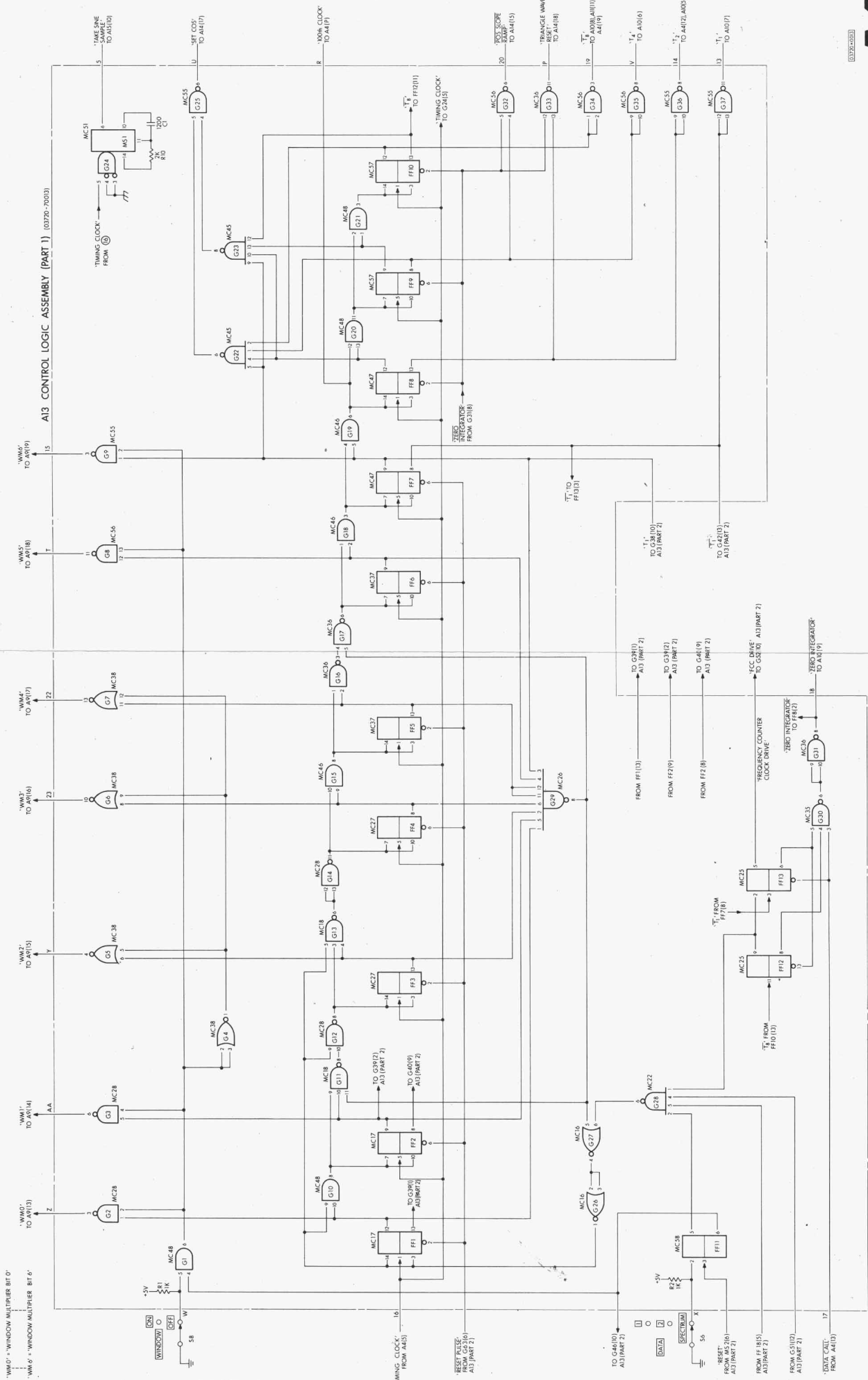

Figure A12-3 Component location, A12



03720*0038

Figure A12-2 Schematic, Line Module and Line Transformer



A13

Figure A13-2 Schematic A13 (part 1), Control Logic assembly

Table A13-1 Component identification grid, A13

C		R	
REF DESIG	GRID LOC	REF DESIG	GRID LOC
C1	A-3	R1	D-3
C2	C-3	R2	D-3
C3	C-3	R3	C-3
C4	C-1	R4	B-3
C5	A-1	R5	A-3
C6	B-1	R6	D-3
C7	C-1	R7	B-3
C8	D-1	R8	B-3
C9	A-3	R9	A-3
CR		R10	A-3
REF DESIG	GRID LOC	R11	C-3
CR1	B-3	R12	C-3
CR2	C-3	TP	
CR3	C-3	REF DESIG	GRID LOC
CR4	A-3	GND	C-2
Q			
REF DESIG	GRID LOC		
Q1	B-3		

Note: For complete reference designation, prefix reference designators with A13

A13 CONTROL LOGIC ASSEMBLY (PART 2) (03720-003)

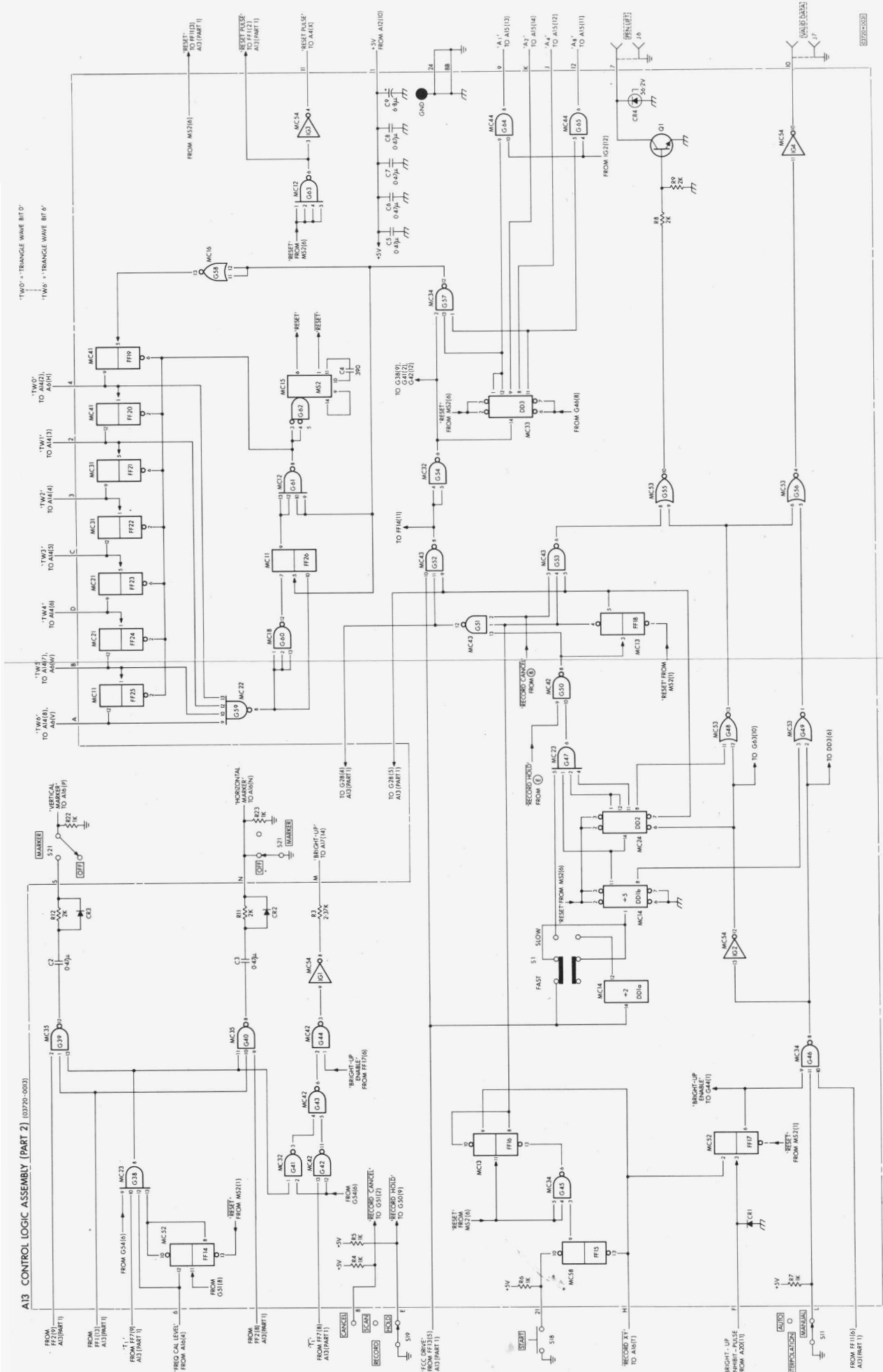

Figure A13-3 Schematic A13 (part 2), Control Logic assembly

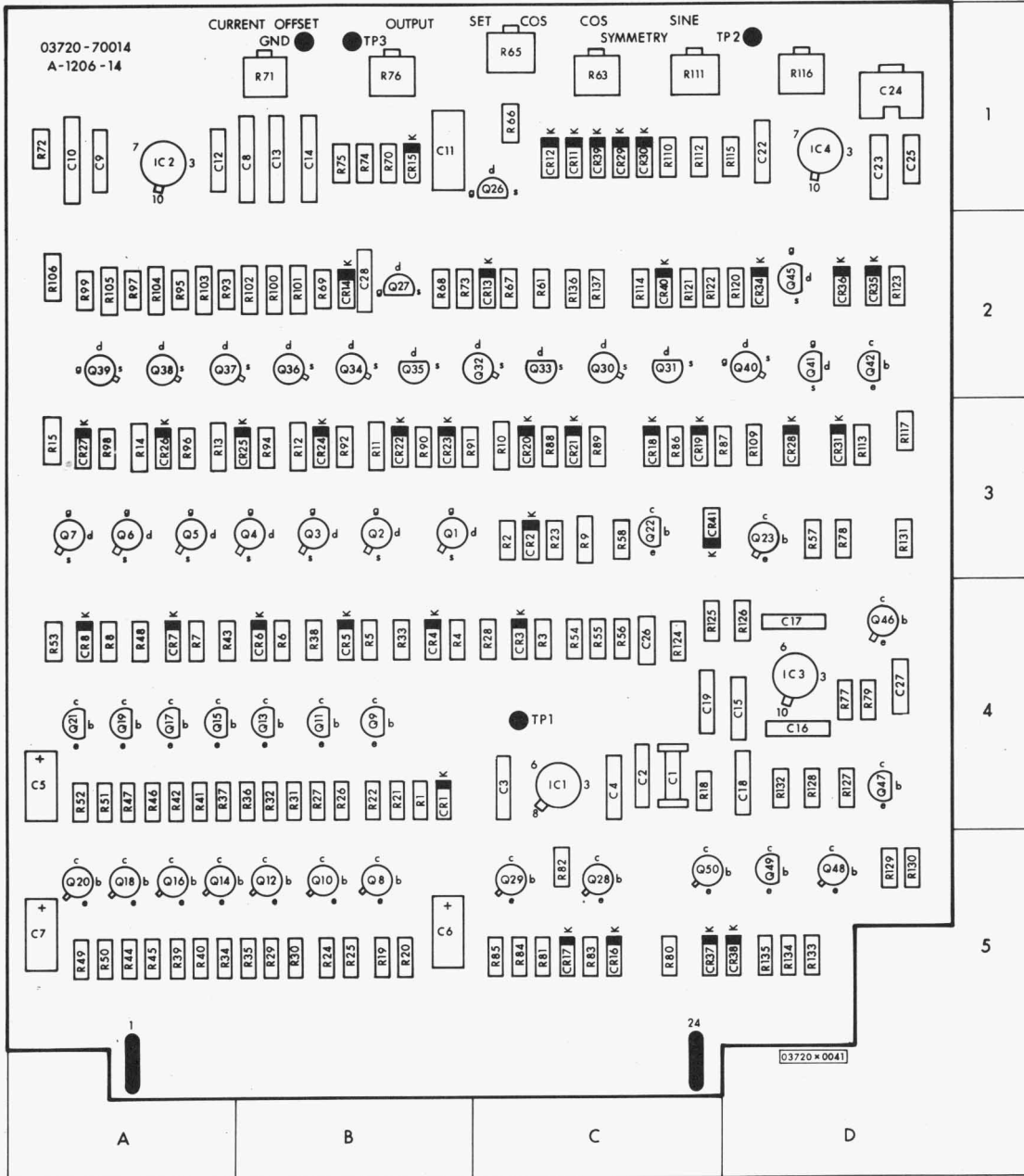
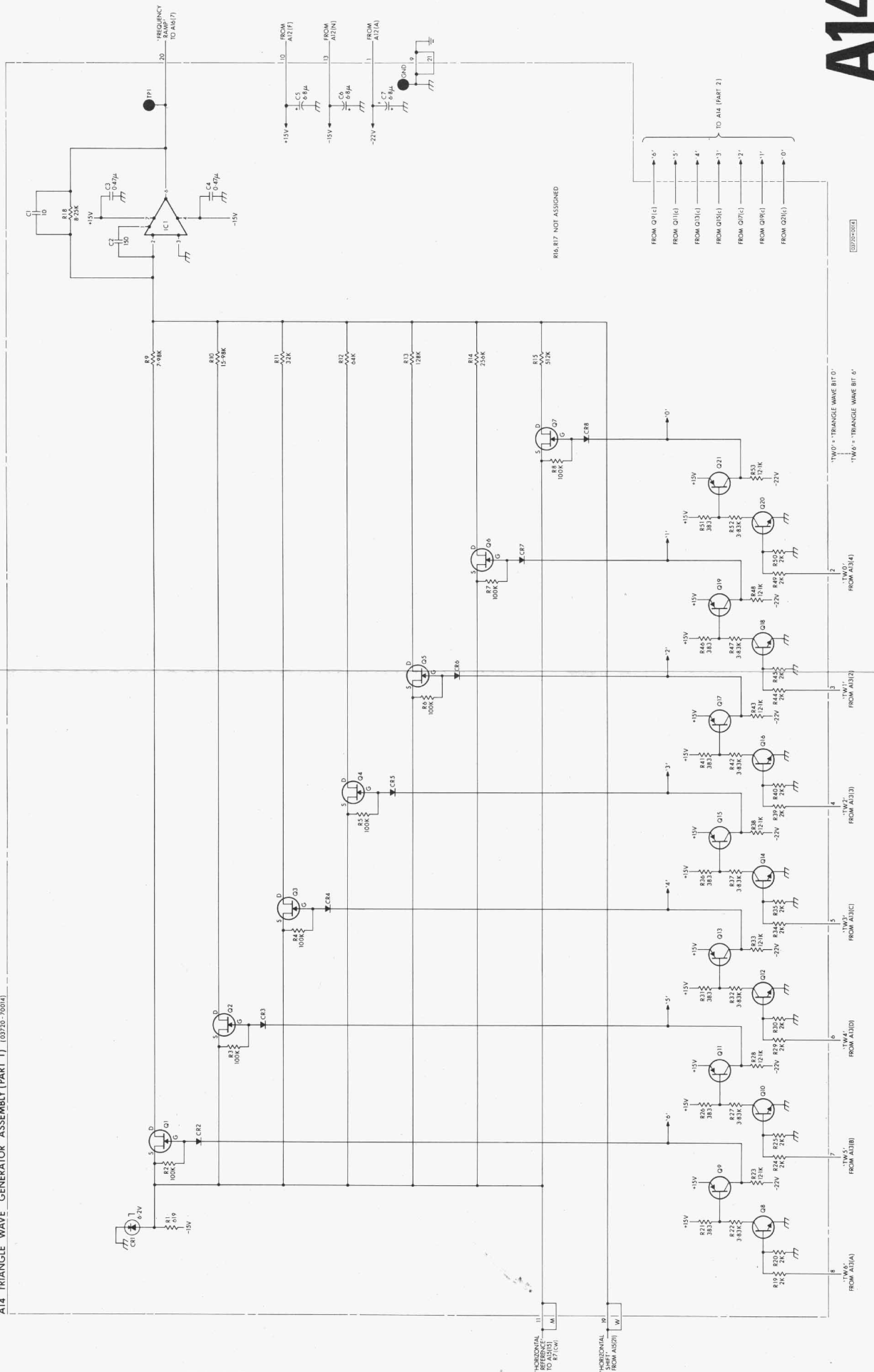
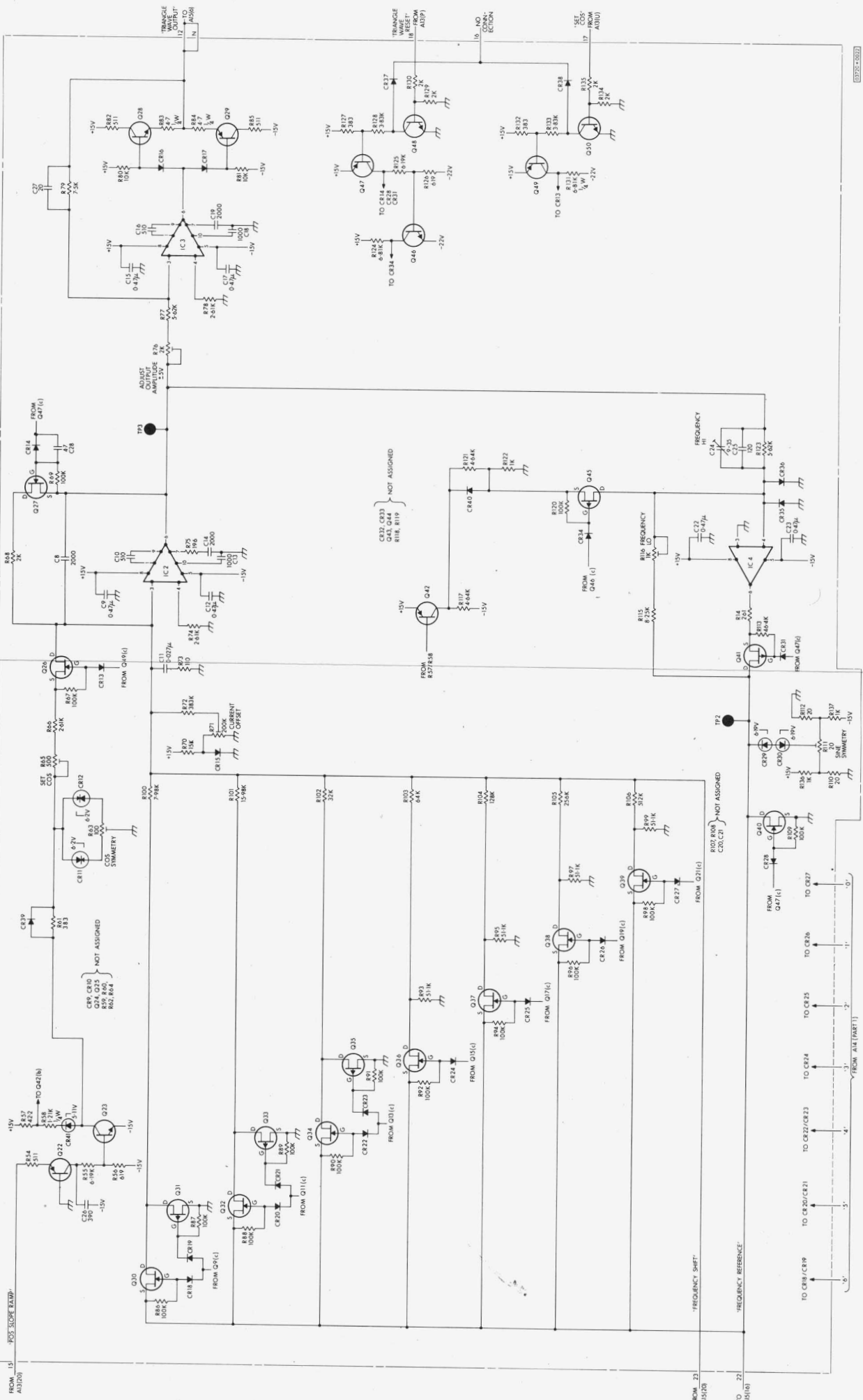

Figure A14-1 Component location, A14



A14

Figure A14-2 Schematic A14 (part 1), Triangle Wave Generator assembly



03770-70041

Figure A14-3 Schematic A14 (part 2), Triangle Wave Generator assembly

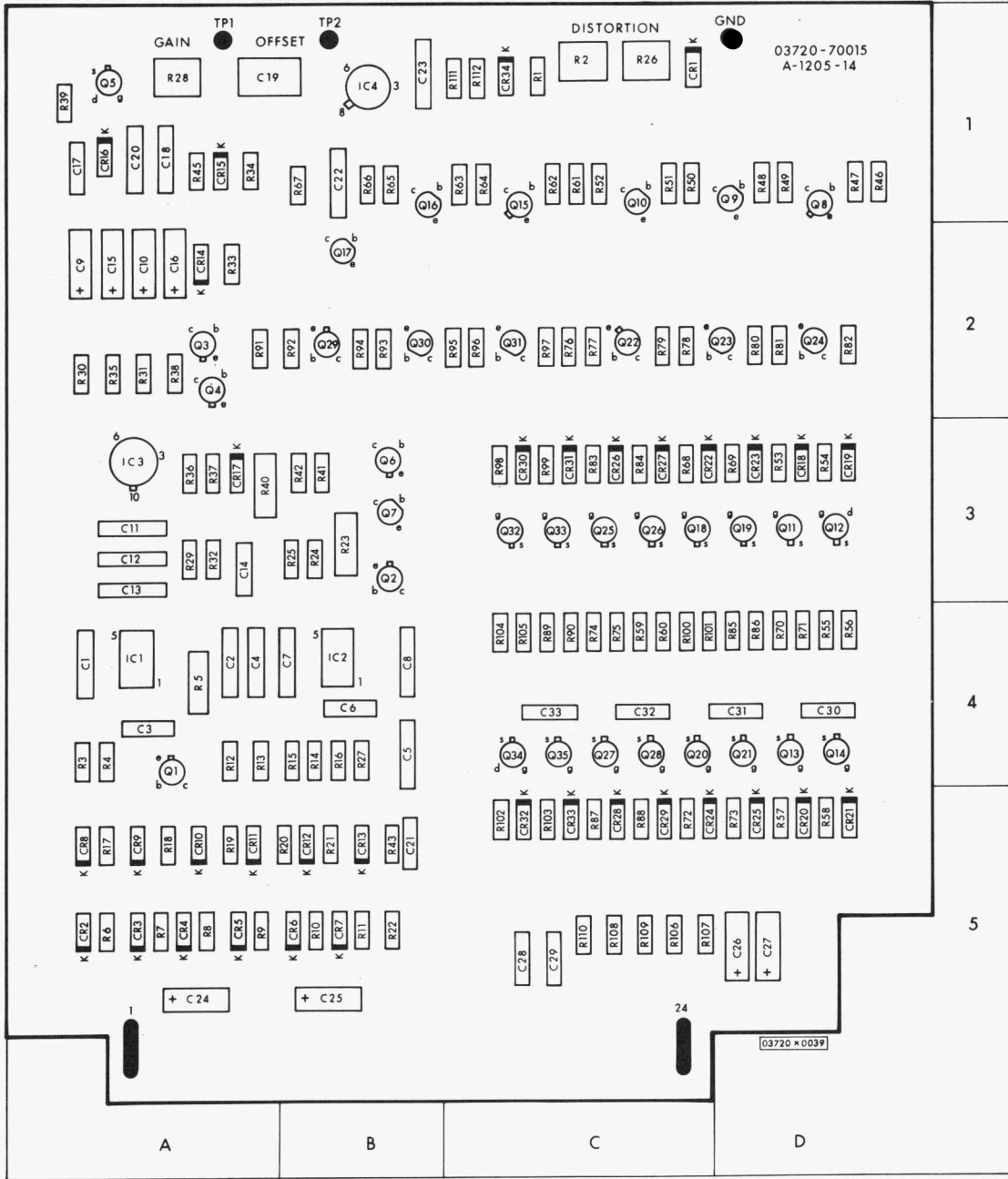
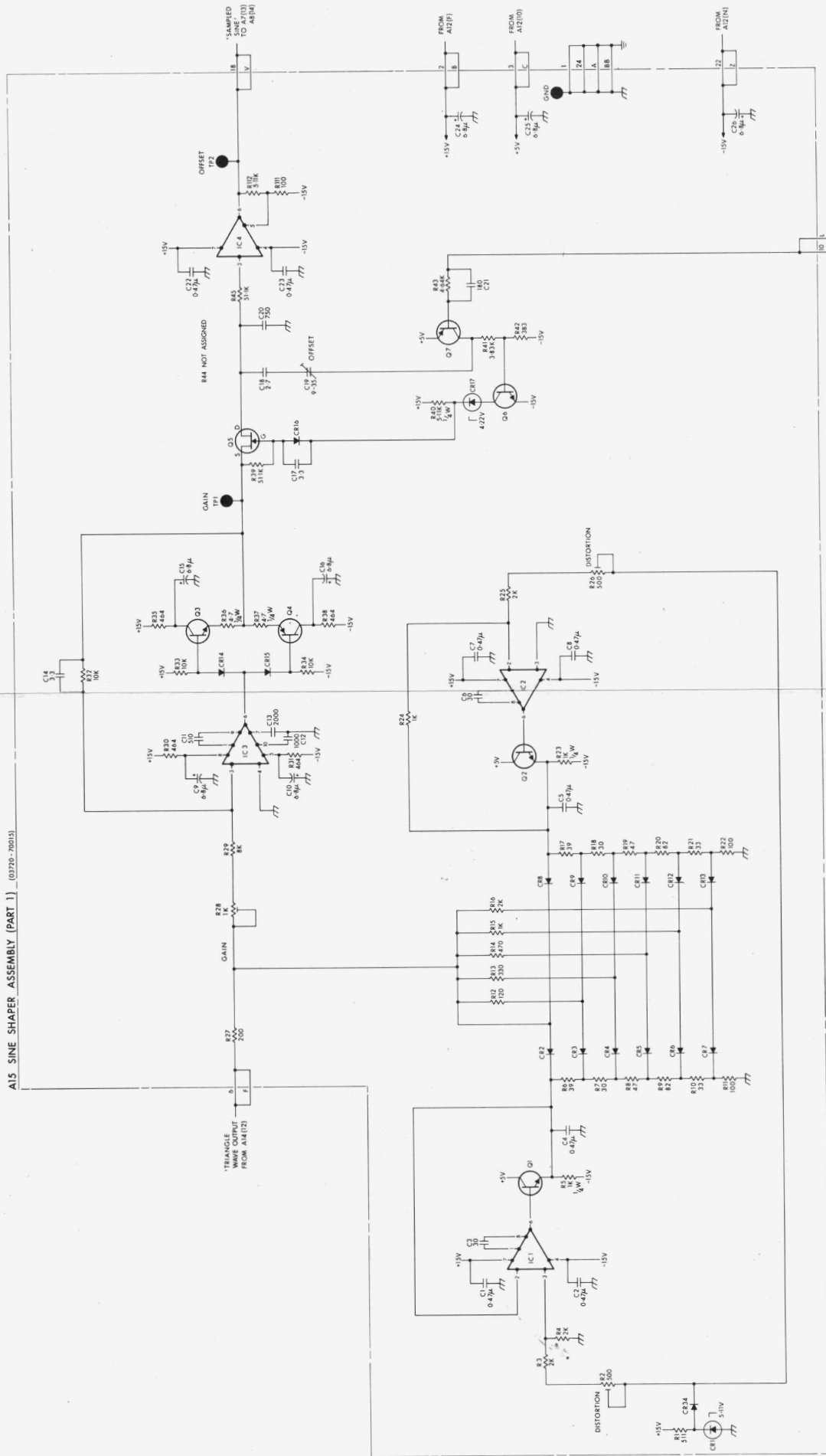

Figure A15-1 Component location, A15



03720-70015

*TAKE SINE SAMPLE FROM A15(1)

A15

Figure A15-2 Schematic A15 (part 1), Sine Shaper assembly 5-47

AI5 SINE SHAPER ASSEMBLY (PART 2) (03720-20015)

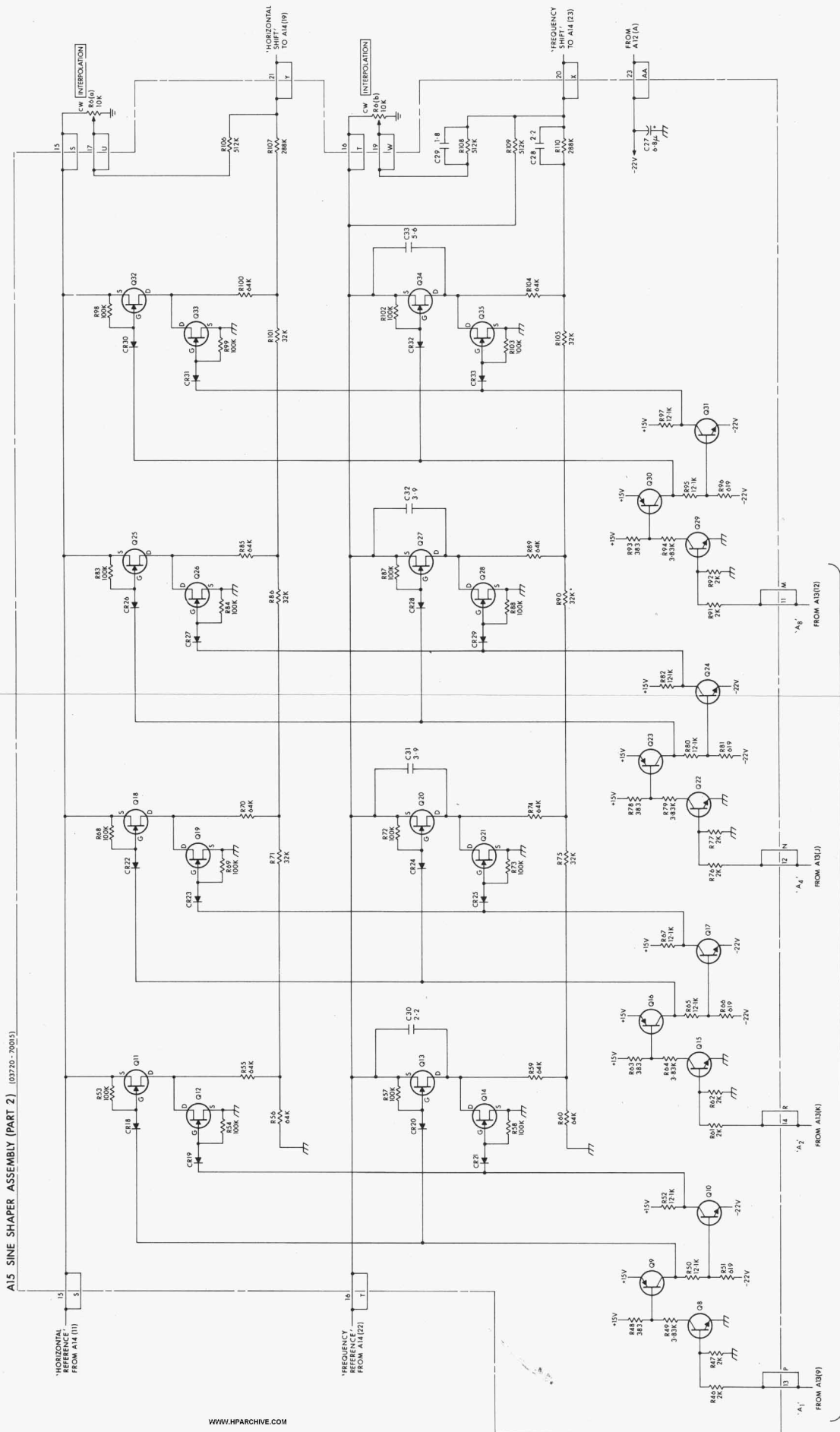
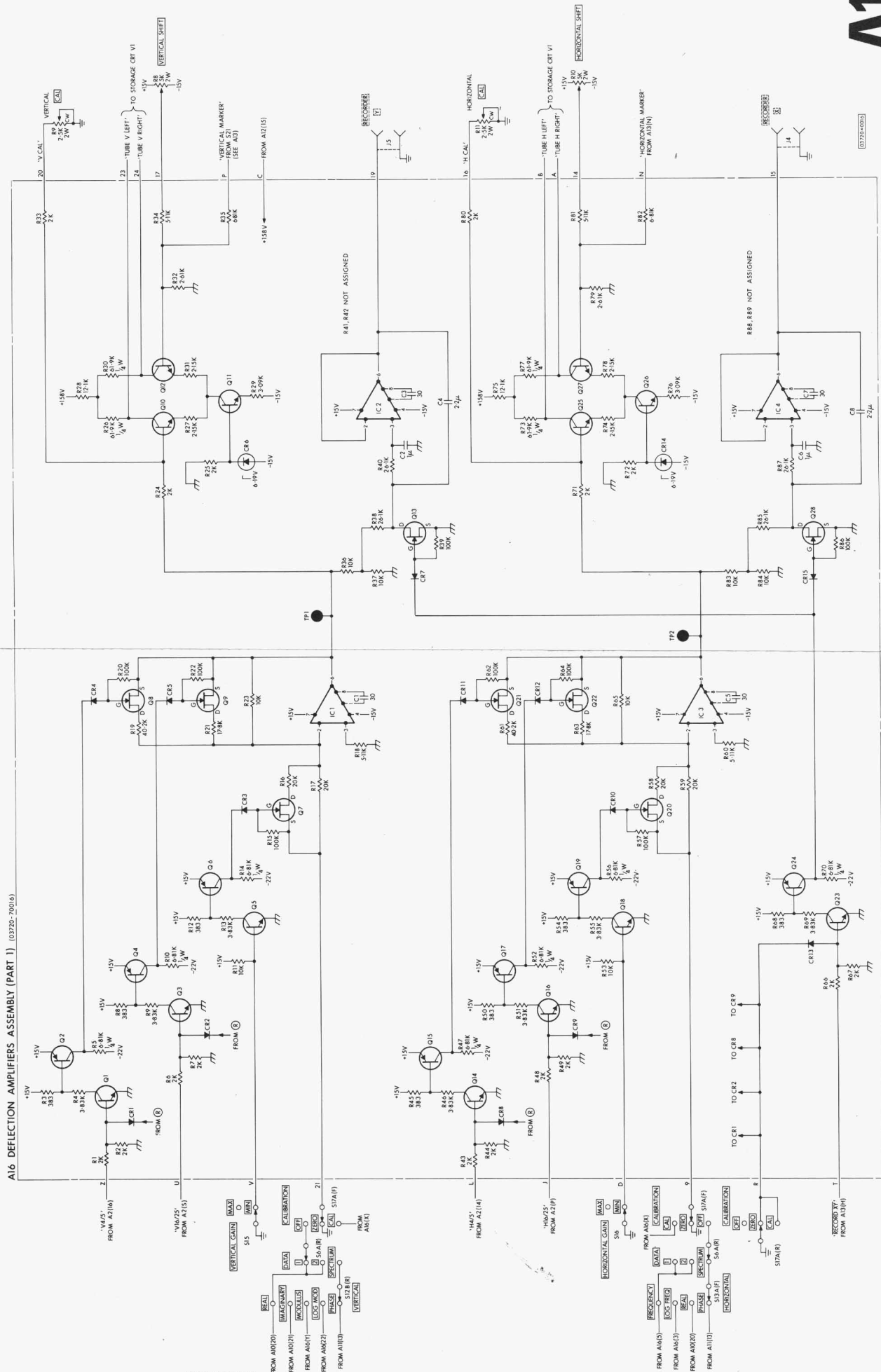

Figure A15-3 Schematic A15 (part 2), Sine Shaper assembly 5-49



A16

Figure A16-2 Schematic A16 (part 1), Deflection Amplifiers assembly 5-51

Table A16-1 Component identification grid, A16

C		CR15	B-3	Q23	B-4	R38	D-2	R90	B-2	R134	A-2
REF	GRID	CR16	A-1	Q24	B-3	R39	C-3	R91	A-1	R135	A-2
DESIG	LOC	CR17	D-1	Q25	B-1	R40	D-2	R92	A-1	R136	A-2
C1	D-2	CR18	A-2	Q26	B-2	R43	B-4	R93	A-1	R137	D-4
C2	C-3	CR19	A-2	Q27	B-1	R44	B-4	R94	A-1	R138	D-4
C3	C-2	CR20	D-4	Q28	B-2	R45	B-3	R95	A-1	R139	D-4
C4	C-2	IC		Q29	A-1	R46	B-3	R96	B-1	TP	
C5	B-2	REF	GRID	Q30	D-1	R47	B-3	R97	B-2	REF	GRID
C6	C-3	DESIG	LOC	R		R48	B-4	R98	A-1	DESIG	LOC
C7	C-2	IC1	D-2	REF	GRID	R49	B-4	R99	A-1	TP1	D-2
C8	C-2	IC2	C-2	DESIG	LOC	R50	B-3	R100	A-1	TP2	A-2
C9	A-1	IC3	B-2	R1	D-4	R51	B-3	R101	B-1	GND	C-1
C10	A-1	IC4	B-2	R2	D-4	R52	A-3	R102	B-1		
C11	B-1	IC5	A-1	R3	D-3	R53	A-4	R103	B-1		
C12	B-1	IC6	B-1	R4	D-3	R54	A-3	R104	A-1		
C13	A-2	IC7	A-2	R5	D-3	R55	A-3	R105	A-1		
C14	D-1	IC8	D-1	R6	C-4	R56	A-3	R106	A-1		
C15	D-1	IC9	C-1	R7	C-4	R57	A-3	R107	A-1		
C16	C-1	IC10	D-2	R8	C-3	R58	A-3	R108	D-1		
C17	C-1	IC11	A-2	R9	C-3	R59	A-3	R109	A-2		
C18	D-2	Q		R10	C-3	R60	B-2	R110	A-2		
C19	C-2	REF	GRID	R11	D-4	R61	B-3	R111	A-2		
C20	B-4	DESIG	LOC	R12	D-3	R62	B-3	R112	A-2		
C21	A-4	Q1	D-4	R13	D-3	R63	B-3	R113	A-2		
C22	C-4	Q2	D-3	R14	C-3	R64	B-3	R114	D-2		
C23	D-4	Q3	C-4	R15	D-3	R65	B-3	R115	D-1		
C24	C-2	Q4	C-3	R16	D-3	R66	C-4	R116	D-1		
C25	A-1	Q5	C-4	R17	D-3	R67	C-4	R117	C-1		
C26	D-1	Q6	C-3	R18	D-2	R68	C-3	R118	D-1		
CR		Q7	D-3	R19	D-2	R69	C-3	R119	D-1		
REF	GRID	Q8	D-3	R20	D-2	R70	B-3	R120	D-2		
DESIG	LOC	Q9	C-3	R21	C-3	R71	B-2	R121	D-2		
CR1	D-4	Q9	C-3	R22	C-3	R72	B-2	R122	C-1		
CR2	C-4	Q10	C-1	R23	C-3	R73	B-1	R123	D-1		
CR3	D-3	Q11	C-2	R24	C-2	R74	B-2	R124	D-1		
CR4	D-3	Q12	C-1	R25	C-2	R75	B-1	R125	C-1		
CR5	C-3	Q13	C-3	R26	C-1	R76	B-2	R126	D-2		
CR6	C-2	Q14	B-4	R27	C-2	R77	B-1	R127	D-2		
CR7	C-3	Q15	B-3	R28	C-1	R78	B-2	R128	D-2		
CR8	B-4	Q16	A-4	R29	C-2	R79	B-4	R129	C-1		
CR9	A-4	Q17	A-3	R30	C-1	R80	B-2	R130	C-1		
CR10	A-3	Q18	A-4	R31	C-2	R81	B-4	R131	D-1		
CR11	B-3	Q19	A-3	R32	C-4	R82	B-4	R132	D-1		
CR12	B-3	Q20	A-3	R33	C-2	R83	B-2	R133	C-1		
CR13	B-4	Q21	B-3	R34	C-4	R84	B-2				
CR14	B-2	Q22	B-3	R35	C-4	R85	B-2				
				R36	C-2	R86	B-2				
				R37	C-2	R87	B-2				

Note: For complete reference designation, prefix reference designators with A16

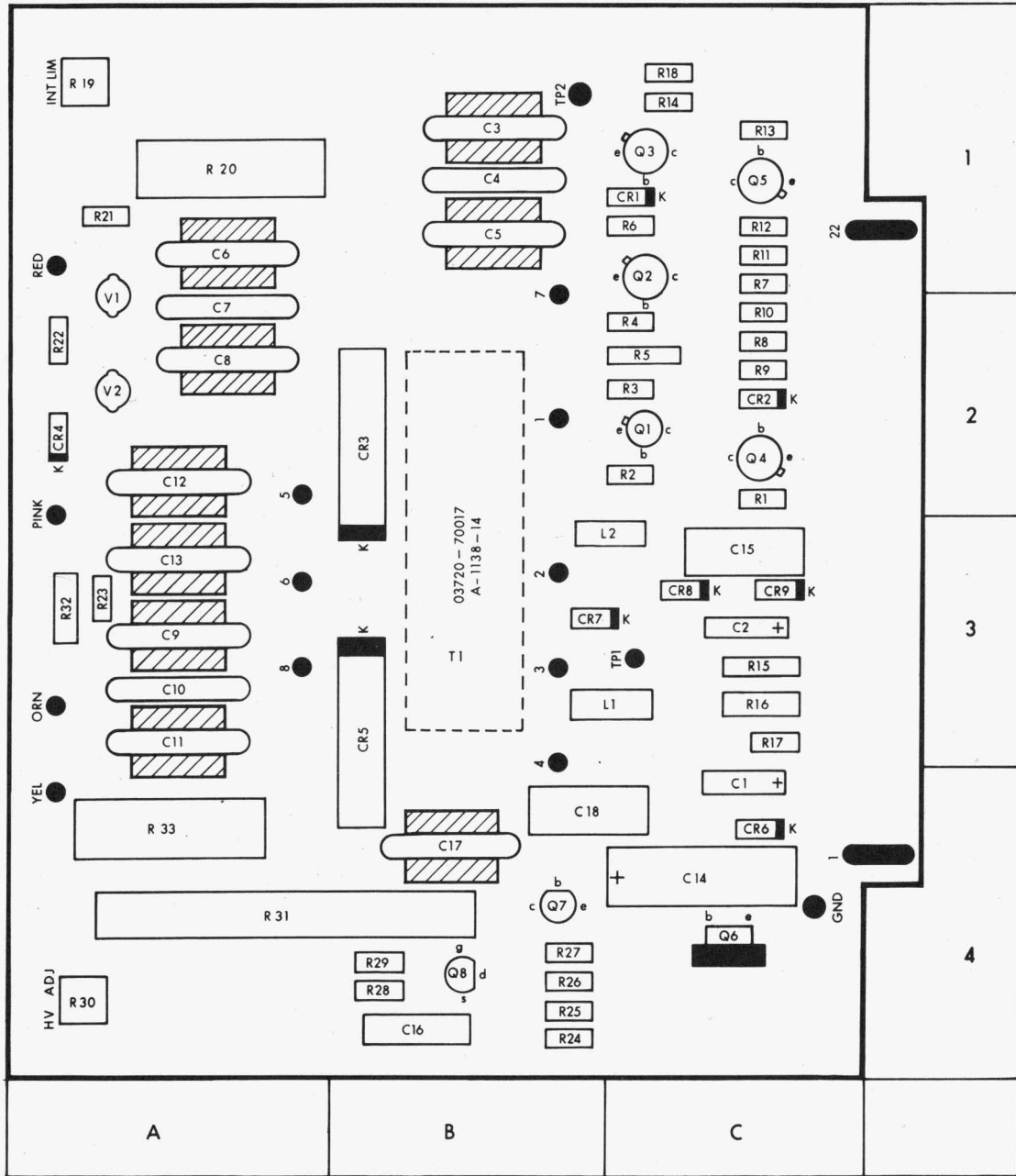
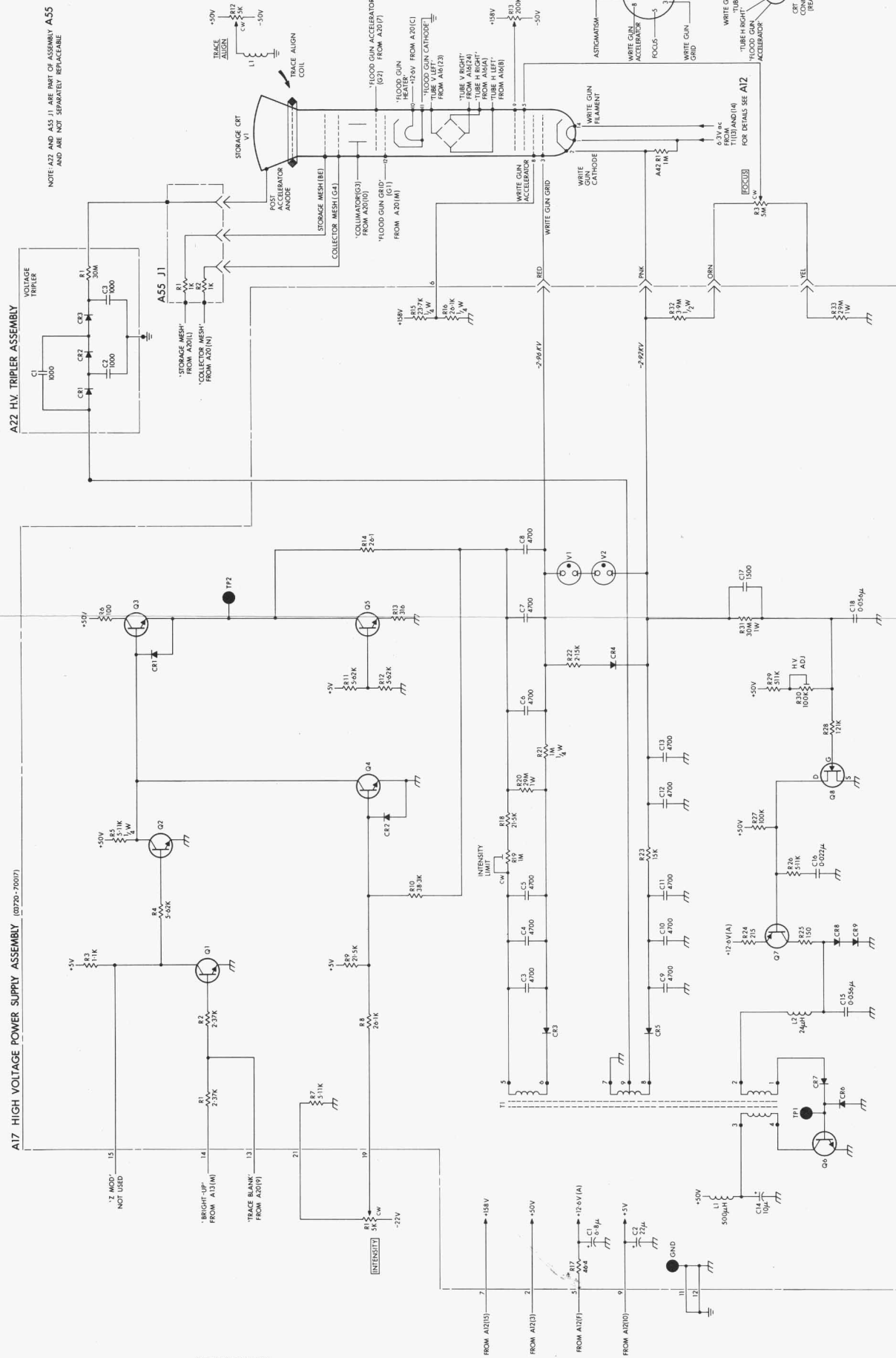

Figure A17-1 Component location, A17



NOTE: A22 AND A55 J1 ARE PART OF ASSEMBLY A55 AND ARE NOT SEPARATELY REPLACEABLE

03732-002

A17

Figure A17-2 Schematic A17, High Voltage Power Supply Assembly

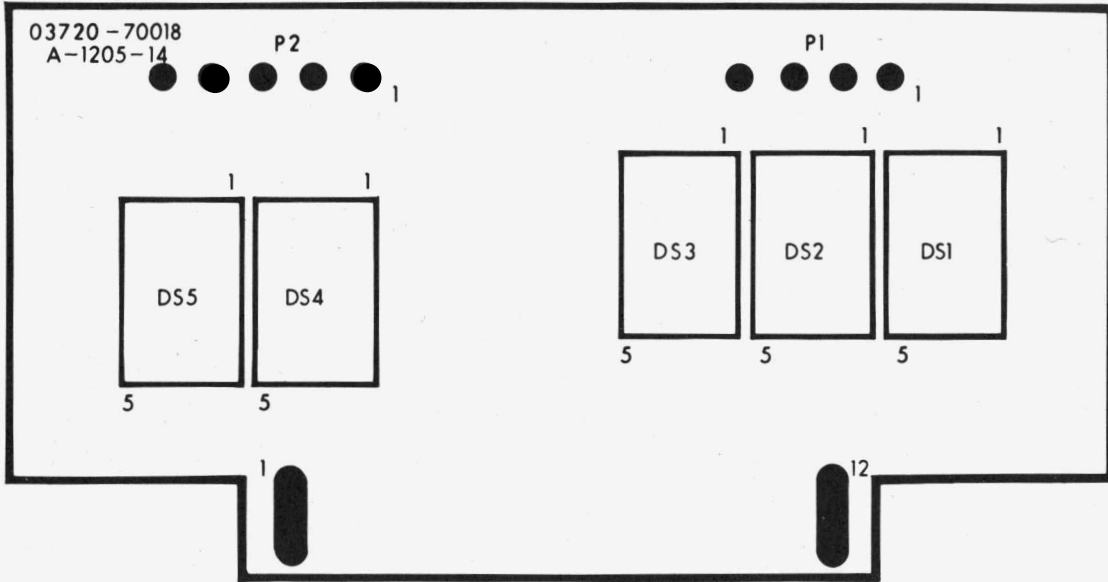

Figure A18-1 Component location, A18

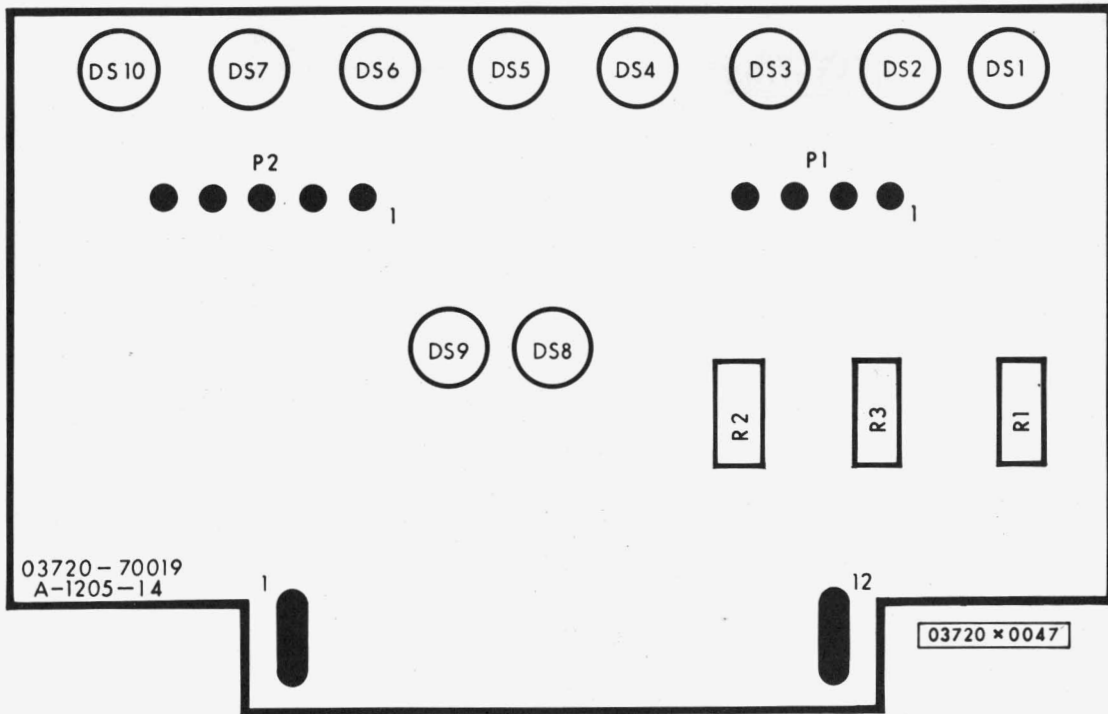

Figure A19-1 Component location, A19

Table A18-1 LED Truth Table

INPUT CHARACTER	*8 P _{IN} 3	*4 2	*2 1	*1 D _{IN} 4	V _E 5
0	0	0	0	0	0
1	0	0	0	1	0
2	0	0	1	0	0
3	0	0	1	1	0
4	0	1	0	0	0
5	0	1	0	1	0
6	0	1	1	0	0
7	0	1	1	1	0
8	1	0	0	0	0
9	1	0	0	1	0
DECIMAL POINT ON	-	-	-	-	0
DECIMAL POINT OFF	-	-	-	-	1
DISPLAY DISABLED	-	-	-	-	1

A18

Figure A18-2 Schematic A18, Range Indicator assembly

A19

Figure A19-2 Schematic A19, Range Units assembly

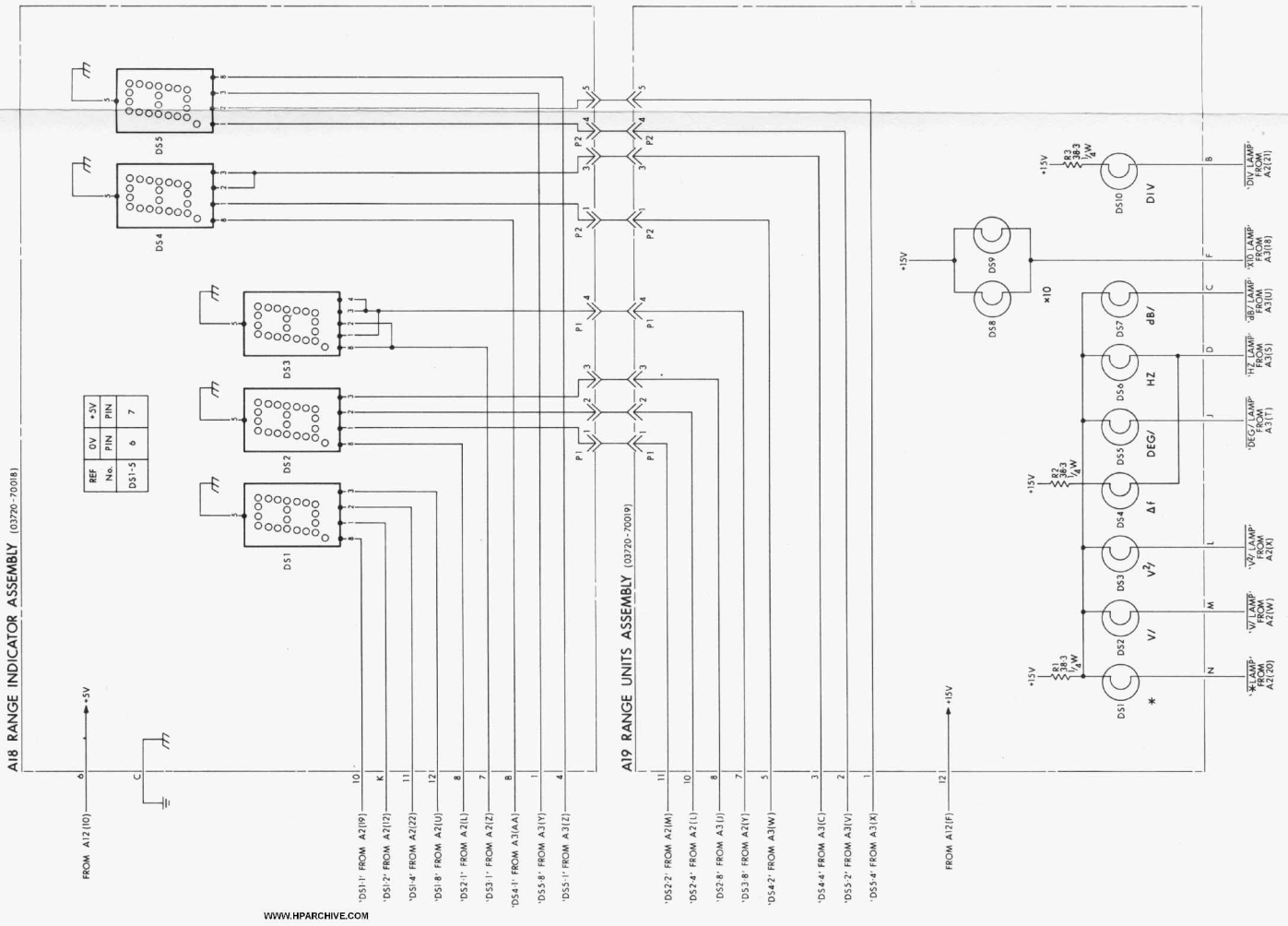

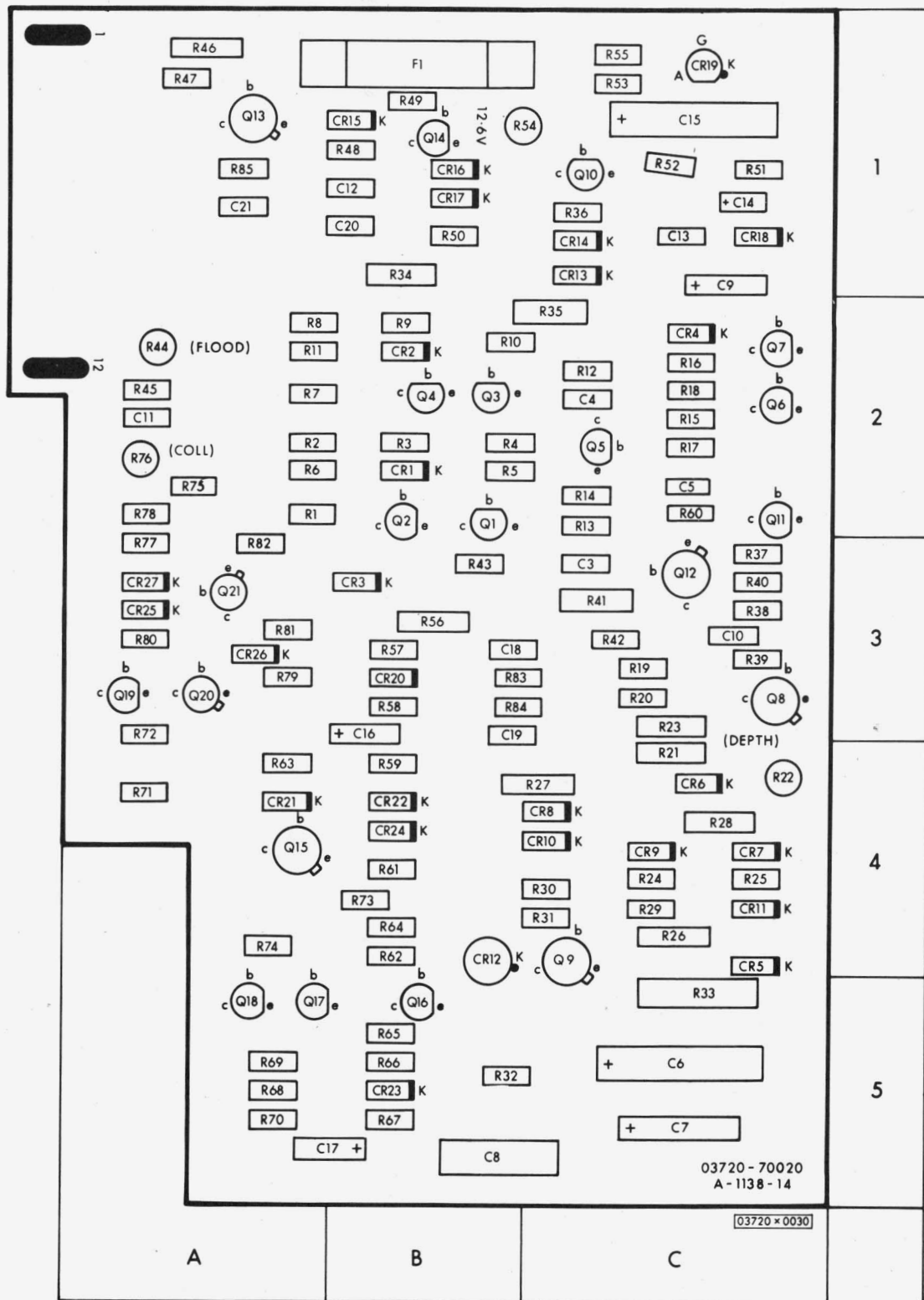
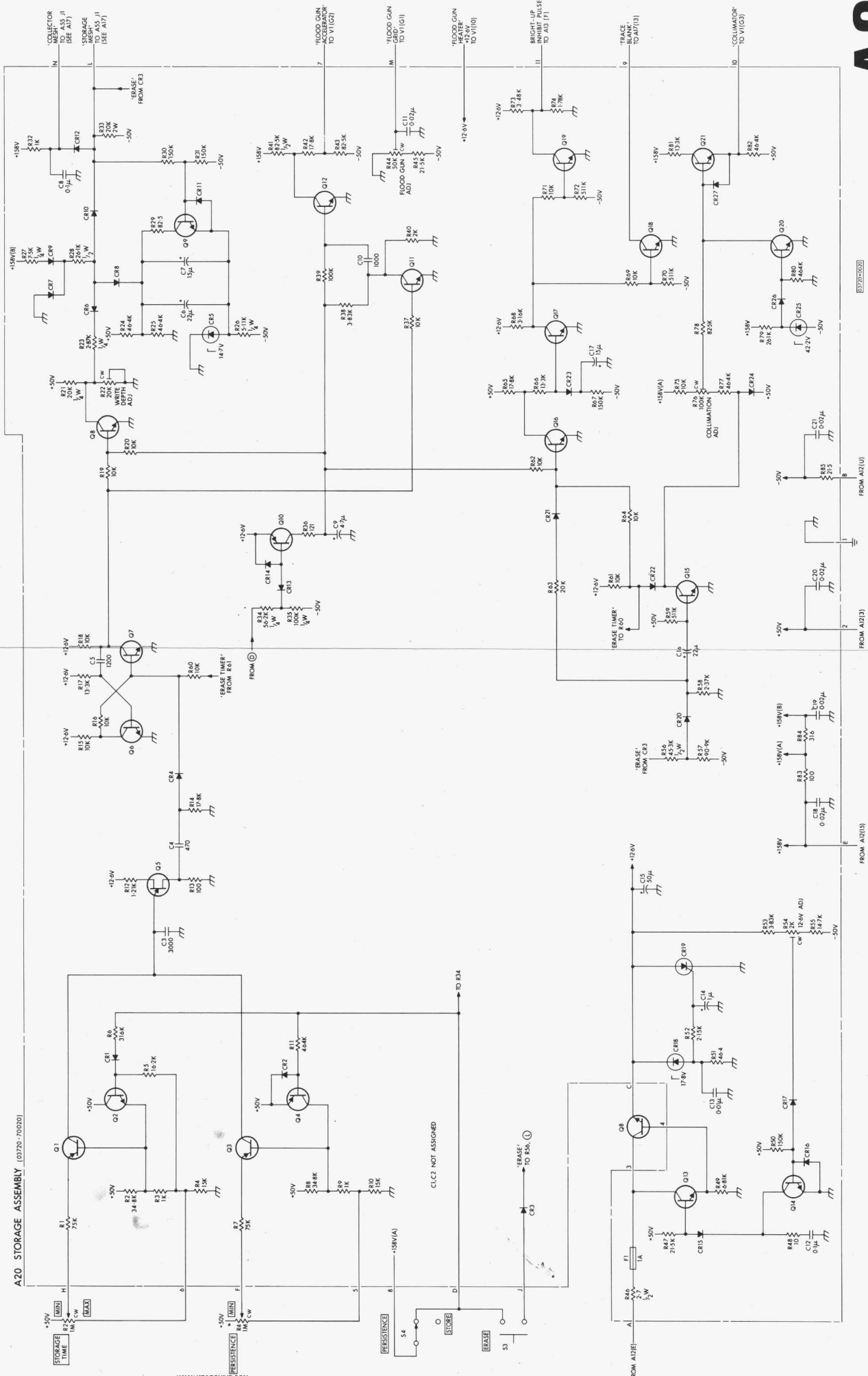

Figure A20-1 Component location, A20

A20 STORAGE ASSEMBLY (03720-70000)



A20

Figure A20-2 Schematic A20, Storage assembly

Table A20-1 Component identification grid, A20

C		CR20	B-3	R		R46	A-1
REF DESIG	GRID LOC	CR21	A-4	REF DESIG	GRID LOC	R47	A-1
C3	C-3	CR22	B-4	R1	A-2	R48	B-1
C4	C-2	CR23	B-5	R2	A-2	R49	B-1
C5	C-2	CR24	B-4	R3	B-2	R50	B-1
C6	C-5	CR25	A-3	R4	B-2	R51	C-1
C7	C-5	CR26	A-3	R5	B-2	R52	C-1
C8	B-5	CR27	A-3	R6	A-2	R53	C-1
C9	C-1	F		R7	A-2	R54	B-1
C10	C-3	REF DESIG	GRID LOC	R8	A-2	R55	C-1
C11	A-2	F1	B-1	R9	B-2	R56	B-3
C12	B-1	Q		R10	B-2	R57	B-3
C13	C-1	REF DESIG	GRID LOC	R11	A-2	R58	B-3
C14	C-1	Q1	B-2	R12	C-2	R59	B-4
C15	C-1	Q2	B-2	R13	C-2	R60	C-2
C16	B-3	Q3	B-2	R14	C-2	R61	B-4
C17	B-5	Q4	B-2	R15	C-2	R62	B-4
C18	B-3	Q5	C-2	R16	C-2	R63	A-4
C19	B-3	Q6	C-2	R17	C-2	R64	B-4
C20	B-1	Q7	C-2	R18	C-2	R65	B-5
C21	A-1	Q8	C-3	R19	C-3	R66	B-5
CR		Q9	C-4	R20	C-3	R67	B-5
REF DESIG	GRID LOC	Q10	C-1	R21	C-4	R68	A-5
CR1	B-2	Q11	C-2	R22	B-4	R69	A-5
CR2	B-2	Q12	C-3	R23	C-3	R70	A-5
CR3	B-3	Q13	A-1	R24	C-4	R71	A-4
CR4	C-2	Q14	B-1	R25	C-4	R72	A-3
CR5	C-4	Q15	A-4	R26	C-4	R73	B-4
CR6	C-4	Q16	B-5	R27	C-4	R74	A-4
CR7	C-4	Q17	A-5	R28	C-4	R75	A-2
CR8	C-4	Q18	A-5	R29	C-4	R76	A-2
CR9	C-4	Q19	A-3	R30	C-4	R77	A-3
CR10	C-4	Q20	A-3	R31	C-4	R78	A-2
CR11	C-4	Q21	A-3	R32	B-5	R79	A-3
CR12	B-4			R33	C-5	R80	A-3
CR13	C-1			R34	B-1	R81	A-3
CR14	C-1			R35	C-2	R82	A-3
CR15	B-1			R36	C-1	R83	B-3
CR16	B-1			R37	C-3	R84	B-3
CR17	B-1			R38	C-3	R85	A-1
CR18	C-1			R39	C-3		
CR19	C-1			R40	C-3		
				R41	C-3		
				R42	C-3		
				R43	B-3		
				R44	A-2		
				R45	A-2		

Note: For complete reference designation, prefix reference designators with A20

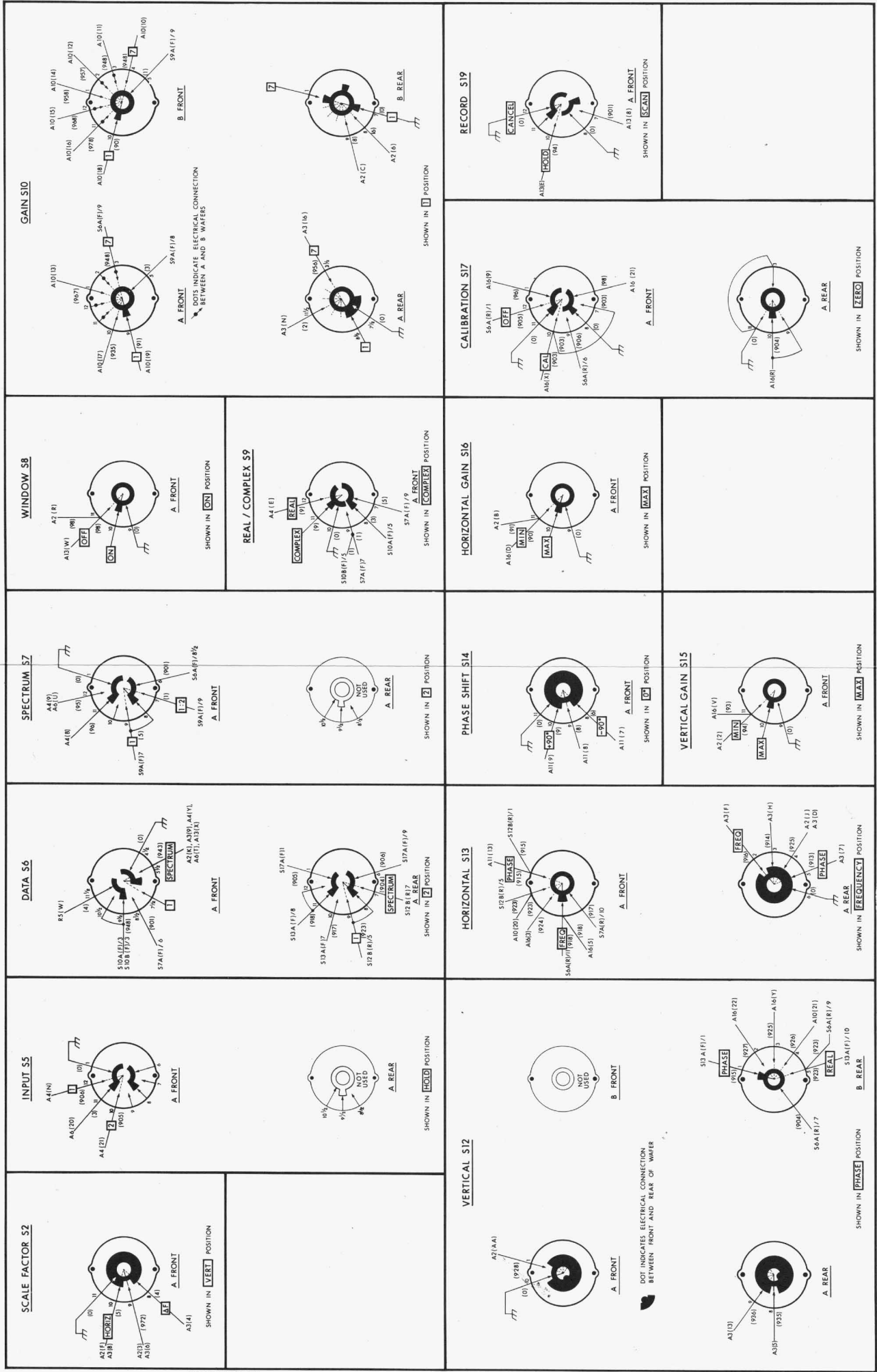

037772026

Figure 5-8 Wiring of rotary switches

Connector	From/To
LINE (J1)	See Figure A12-2
X (J4)	A16(15)
Y (J5)	A16(19)
PEN LIFT (J6)	A13(7)
VALID DATA (J7)	A13(10)

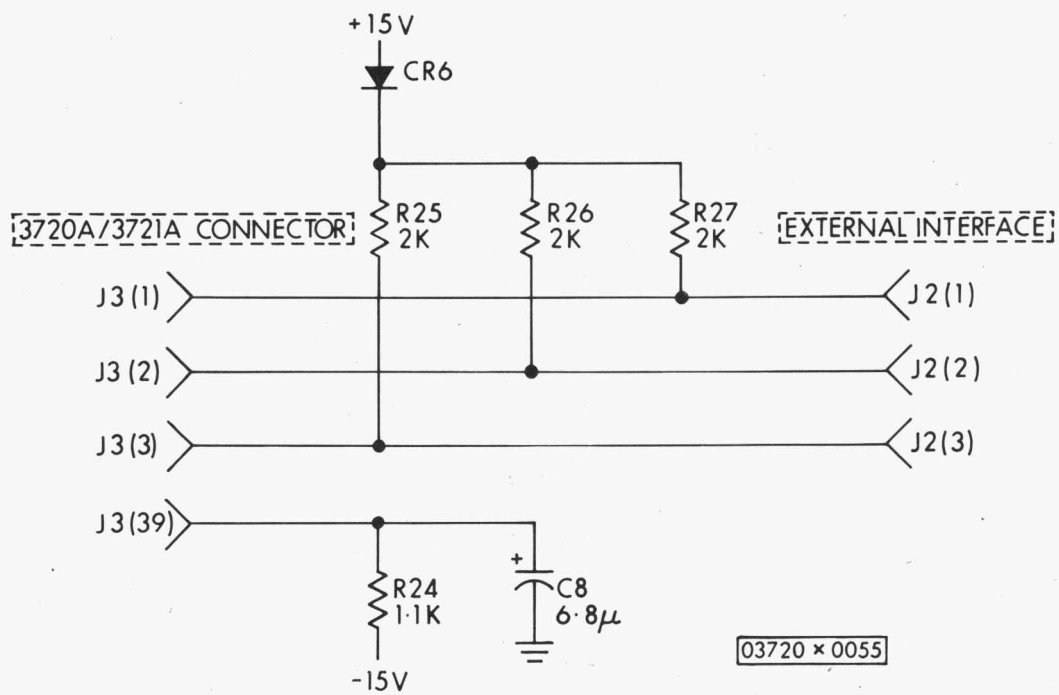

EXTERNAL INTERFACE J2 Pin Number	Title	From/To
1 - 37	-	As J3
38	'COMPUTER CALL'	A6(17)
39	-	-
40	'DATA READY'	A6(18)
41	-	-
42	-	-
43 - 50	-	As J3

Figure 5-9 Wiring of rear panel connectors

3720A/3721A CONNECTOR J3 Pin Number	Title	From/To	
		EXTERNAL INTERFACE J2 Pin Number	Assembly Connection
26	'HIGHWAY 0'	26	A6(3)
27	'HIGHWAY 1'	27	A6(4)
28	'HIGHWAY 2'	28	A6(5)
29	'HIGHWAY 3'	29	A6(6)
30	'HIGHWAY 4'	30	A6(8)
31	'HIGHWAY 5'	31	A6(9)
32	'HIGHWAY 6'	32	A6(10)
33	'HIGHWAY 7'	33	A6(11)
34	'HIGHWAY 8'	34	A6(12)
35	'HIGHWAY 9'	35	A6(13)
36	'HIGHWAY 10'	36	A6(14)
37	'HIGHWAY 11'	37	A6(15)
38	'TRANSFER DATA'	—	A6(19)
39	'COMPUTER SPEED READOUT'	—	R24/C8
40	'DATA READY'	—	A6(16)
41	'750KHz'	—	A6(AA)
42	'DATA CALL'	—	A6(22)
43	'STOP'	43	—
44		44	—
45	'CT3'	45	A2(17)
46	'16/25'	46	A2(H)
47	'4/5'	47	A2(T)
48	'SIG REC'	48	A2(V)
49	—	—	—
50	GND	50	GND

3720A/3721A CONNECTOR J3 Pin Number	Title	From/To	
		EXTERNAL INTERFACE J2 Pin Number	Assembly Connection
1	Remote ' <u>RESET</u> ' (in)	1	—
1	Remote ' <u>HOLD</u> ' (in)	2	—
3	Remote ' <u>RUN</u> ' (in)	3	—
4	' <u>RUN</u> ' Indication (out)	4	—
5	' <u>HOLD</u> ' Indication (out)	5	—
6	' <u>RESET</u> ' Indication (out)	6	—
7	'ZERO MOMENT'	7	—
8	'ZERO MOMENT'	8	—
9	—	—	—
10	' <u>MANUAL SUM</u> '	10	—
11	Delay Offset ' <u>700 + 800</u> '	11	—
12	Delay Offset ' <u>300 + 400</u> '	12	—
13	Delay Offset ' <u>ODD</u> '	13	—
14	Delay Offset ' <u>900 + 1000</u> '	14	—
15	Delay Offset ' <u>500 + 600</u> '	15	—
16	Delay Offset ' <u>100 + 200</u> '	16	—
17	Delay Offset ' <u>50</u> '	17	—
18	Delay Offset ' <u>0</u> '	18	—
19	—	19	—
20	' <u>EXT \emptyset</u> '	20	A2(E), A3(15)
21	' <u>NEG EXP</u> '	21	A3(21)
22	' <u>X 10¹</u> '	22	A3(22)
23	' <u>X 10²</u> '	23	A3(19)
24	' <u>X 10³</u> '	24	A3(20)
25	GND	25	GND



CATHODE-RAY TUBE WARRANTY

The cathode-ray tube (CRT) supplied in your Hewlett-Packard instrument and replacement CRT's purchased from hp are warranted by the Hewlett-Packard Company against electrical failure for a period of one year from the date of sale. Broken tubes and tubes with phosphor or mesh burns are not included under this warranty. If the CRT is broken when received, a claim should be made with the responsible carrier.

Your nearest Hewlett-Packard Sales/Service Office (listed at rear of instrument manual) maintains a stock of replacement tubes and will assist in processing the warranty claim.

We would like to evaluate every defective CRT. This engineering evaluation helps us to provide a better product for you. Please fill out the CRT Failure Report on the reverse side of this sheet and return it with the defective CRT to:

Hewlett-Packard Limited,
South Queensferry,
West Lothian, Scotland.

Attention:- CRT QA

To avoid damage to the tube while in shipment, please follow the shipping instructions below; warranty credit is not allowed on broken tubes.

SHIPPING INSTRUCTIONS

It is preferable that the defective CRT be returned in the replacement CRT carton. If the carton or packaging material is not available, pack the CRT according to the instructions below:

1. Carefully wrap the tube in $\frac{1}{2}$ inch thick cotton batting or other soft padding material.
2. Wrap the above in heavy kraft paper.
3. Pack wrapped tube in a rigid container which is at least 4 inches larger than the tube in each dimension.
4. Surround the tube with at least 4 inches of packed excelsior or similar shock absorbing material; be sure the packing is tight all around the tube.

Thank you,

CRT Department



CATHODE-RAY TUBE FAILURE REPORT

DATE _____

FROM:

NAME _____

COMPANY _____

ADDRESS _____

1. hp INSTRUMENT MODEL NO. _____

2. hp INSTRUMENT SERIAL NO. _____

3. CRT SERIAL NO. _____

4. Please describe the failure and, if possible, show the trouble on the appropriate CRT face below.

CUT ALONG DOTTED LINE

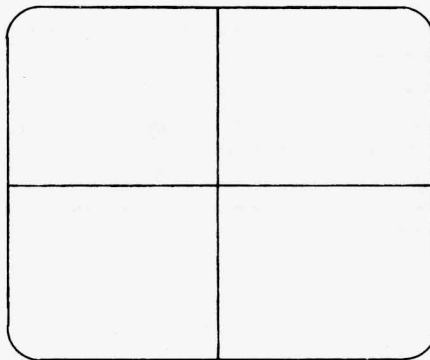

5. Is the CRT within warranty? Yes _____ No _____

6. hp Sales/Service Office _____ Repair Order No. _____

**ELECTRONIC
SALES & SERVICE OFFICES**

UNITED STATES

ALABAMA
P.O. Box 4207
2003 Byrd Spring Road S.W.
Huntsville 35802
Tel: (205) 881-4591
TWX: 810-726-2204

ARIZONA
2336 E. Magnolia St.
Phoenix 85034
Tel: (602) 252-5061
TWX: 910-951-1330

5737 East Broadway
Tucson 85716
Tel: (602) 298-2313
TWX: 910-952-1162

CALIFORNIA
1430 East Orangethorpe Ave.
Fullerton 92631
Tel: (714) 870-1000

3939 Lankershim Boulevard
North Hollywood 91604
Tel: (213) 877-1282
TWX: 910-499-2170

1101 Embarcadero Road
Palo Alto 94303
Tel: (415) 327-6500
TWX: 910-373-1280

2220 Watt Ave.
Sacramento 95825
Tel: (916) 482-1463
TWX: 910-367-2092

9606 Aero Drive
San Diego 92123
Tel: (714) 279-3200
TWX: 910-335-2000

COLORADO
7965 East Prentice
Englewood 80110
Tel: (303) 771-3455
TWX: 910-935-0705

CONNECTICUT
508 Tolland Street
East Hartford 06108
Tel: (203) 289-9394
TWX: 710-425-3416

111 East Avenue
Norwalk 06851
Tel: (203) 853-1251
TWX: 710-468-3750

FLORIDA
P.O. Box 24210
2806 W. Oakland Park Blvd.
Ft. Lauderdale 33307
Tel: (305) 731-2020
TWX: 510-955-4099

P.O. Box 20007
Herndon Station 32814
621 Commonwealth Avenue
Orlando
Tel: (305) 841-3970
TWX: 810-850-0113

Effective April 1, 1972
P.O. Box 13910
6177 Lake Ellenor Dr.
Orlando, 32809
Tel: (305) 859-2900
TWX: 810-850-0113

GEORGIA
P.O. Box 28234
450 Interstate North
Atlanta 30328
Tel: (404) 436-6181
TWX: 810-766-4890

ILLINOIS
5500 Howard Street
Skokie 60076
Tel: (312) 677-0400
TWX: 910-223-3613

INDIANA
3839 Meadows Drive
Indianapolis 46205
Tel: (317) 546-4891
TWX: 810-341-3263

LOUISIANA
P.O. Box 856
1942 Williams Boulevard
Kenner 70062
Tel: (504) 721-6201
TWX: 810-955-5524

MARYLAND
6707 Whitestone Road
Baltimore 21207
Tel: (301) 944-5400
TWX: 710-862-9157

P.O. Box 1648
2 Choke Cherry Road
Rockville 20850
Tel: (301) 948-6370
TWX: 710-828-9684

MASSACHUSETTS
32 Hartwell Ave.
Lexington 02173
Tel: (617) 861-8960
TWX: 710-326-6904

MICHIGAN
21840 West Nine Mile Road
Southfield 48075
Tel: (313) 353-9100
TWX: 810-224-4882

MINNESOTA
2459 University Avenue
St. Paul 55114
Tel: (612) 645-9461
TWX: 910-563-3734

MISSOURI
11131 Colorado Ave.
Kansas City 64137
Tel: (816) 763-8007
TWX: 910-771-2087

2812 South Brentwood Blvd.
St. Louis 63144
Tel: (314) 962-5000
TWX: 910-760-1670

NEW JERSEY
W. 120 Century Road
Paramus 07652
Tel: (201) 265-5000
TWX: 710-990-4951

1060 N. Kings Highway
Cherry Hill 08034
Tel: (609) 667-4000
TWX: 810-892-4945

NEW MEXICO
P.O. Box 8366
Station C
6501 Lomas Boulevard N.E.
Albuquerque 87108
Tel: (505) 265-3713
TWX: 910-989-1665

NEW YORK
1702 Central Avenue
Albany 12205
Tel: (518) 869-8462
TWX: 710-441-8270

1219 Campville Road
Endicott 13760
Tel: (607) 754-0050
TWX: 510-252-0890

82 Washington Street
Poughkeepsie 12601
Tel: (914) 454-7330
TWX: 510-248-0012

39 Saginaw Drive
Rochester 14623
Tel: (716) 473-9500
TWX: 510-253-5981

5858 East Molloy Road
Syracuse 13211
Tel: (315) 454-2486
TWX: 710-541-0482

1 Crossways Park West
Woodbury 11797
Tel: (516) 921-0300
TWX: 510-223-0811

NORTH CAROLINA
P.O. Box 5188
2745 Dutch Village Rd.
Suite 206
Haltifax
Tel: (902) 455-0511
TWX: 610-271-4482

OHIO
25575 Center Ridge Road
Cleveland 44145
Tel: (216) 835-0300
TWX: 810-427-9129

3460 South Dixie Drive
Dayton 45439
Tel: (513) 298-0351
TWX: 810-459-1925

1120 Morse Road
Columbus 43229
Tel: (614) 846-1300

OKLAHOMA
2919 United Founders Boulevard
Oklahoma City 73112
Tel: (405) 848-2801
TWX: 910-830-6862

OREGON
Westhills Mall, Suite 158
4475 S.W. Scholls Ferry Road
Portland 97225
Tel: (503) 292-9171
TWX: 910-464-6103

PENNSYLVANIA
2500 Moss Side Boulevard
Monroeville 15146
Tel: (412) 271-0724
TWX: 710-797-3650

1021 8th Avenue
King of Prussia Industrial Park
King of Prussia 19406
Tel: (215) 265-7000
TWX: 510-660-2670

RHODE ISLAND
873 Waterman Ave.
East Providence 02914
Tel: (401) 434-5535
TWX: 710-381-7573

***TENNESSEE**
Memphis
Tel: (901) 274-7472

TEXAS
P.O. Box 1270
201 E. Arapahoe Rd.
Richardson 75080
Tel: (214) 231-6101
TWX: 910-867-4723

P.O. Box 22813
6300 Westpark Drive
Suite 100
Houston 77027
Tel: (713) 781-6000
TWX: 910-881-2645

231 Billy Mitchell Road
San Antonio 78226
Tel: (512) 434-4171
TWX: 910-871-1170

UTAH
2890 South Main Street
Salt Lake City 84115
Tel: (801) 487-0715
TWX: 910-925-5681

VERMONT
P.O. Box 2287
Kennedy Drive
South Burlington 05401
Tel: (802) 658-4455
TWX: 510-299-0025

VIRGINIA
P.O. Box 6514
2111 Spencer Road
Richmond 23230
Tel: (703) 285-3431
TWX: 710-956-0157

WASHINGTON
433-108th N.E.
Bellevue 98004
Tel: (206) 454-3971
TWX: 910-443-2303

***WEST VIRGINIA**
Charleston
Tel: (304) 768-1232

FOR U.S. AREAS NOT LISTED:
Contact the regional office nearest you: Atlanta, Georgia... North Hollywood, California... Paramus, New Jersey... Skokie, Illinois. Their complete addresses are listed above.

*Service Only

CANADA

ALBERTA
Hewlett-Packard (Canada) Ltd.
11745 Jasper Ave.
Edmonton
Tel: (403) 482-5561
TWX: 610-831-2431

BRITISH COLUMBIA
Hewlett-Packard (Canada) Ltd.
4519 Canada Way
North Burnaby 2
Tel: (604) 433-8213
TWX: 610-922-5059

MANITOBA
Hewlett-Packard (Canada) Ltd.
511 Bradford Ct.
Winnipeg
Tel: (204) 786-7581
TWX: 610-671-3531

NOVA SCOTIA
Hewlett-Packard (Canada) Ltd.
2745 Dutch Village Rd.
Suite 206
Haltifax
Tel: (902) 455-0511
TWX: 610-271-4482

ONTARIO
Hewlett-Packard (Canada) Ltd.
880 Lady Ellen Place
Ottawa 3
Tel: (613) 255-6180, 255-6530
TWX: 610-562-1952

QUEBEC
Hewlett-Packard (Canada) Ltd.
275 Hymus Boulevard
Pointe Claire
Tel: (514) 697-4232
TWX: 610-422-3022
Telex: 01-20607

FOR CANADIAN AREAS NOT LISTED:
Contact Hewlett-Packard (Canada) Ltd. in Pointe Claire, at the complete address listed above.

CENTRAL AND SOUTH AMERICA

ARGENTINA
Hewlett-Packard Argentina
S.A.C.e.I.
Lavalle 1171 - 3°
Buenos Aires
Tel: 35-0436, 35-0627, 35-0431
Telex: 012-1009
Cable: HEWPACKARG

BRAZIL
Hewlett-Packard Do Brasil
I.e.C. Ltda.
Rua Frel Caneca 1119
Sao Paulo - 3, SP
Tel: 288-7111, 287-5858
Cable: HEWPACK Sao Paulo

Hewlett-Packard Do Brasil
Praca Dom Feliciano 78
Salas 806/808
Porto Alegre

Rio Grande do Sul (RS)-Brasil
Tel: 25-8470
Cable: HEWPACK Porto Alegre

Hewlett-Packard Do Brasil
I.e.C. Ltda.
Rua da Matriz 29
Botafogo ZC-02
Rio de Janeiro, GB
Tel: 246-4417
Cable: HEWPACK Rio de Janeiro

CHILE
Héctor Calcagni y Cia, Ltda.
Bustos, 1932-3er Piso
Casilla 13942
Santiago
Tel: 423 96
Cable: CALCAGNI Santiago

COLOMBIA
Instrumentacion
Henrik A. Langebaek & Kier
Ltda.
Carrera 7 No. 48-59
Apartado Aereo 6287
Bogota, 1 D.E.
Tel: 45-78-06, 45-55-46
Cable: AARIS Bogota
Telex: 44400 INSTCO

COSTA RICA
Lic. Alfredo Gallegos Guardián
Apartado 10159
San José
Tel: 21-86-13
Cable: GALGUR San José

ECUADOR
Laboratorios de Radio-Ingenieria
Calle Guayaquil 1246
Post Office Box 3199
Quito
Tel: 212-496; 219-185
Cable: HORVATH Quito

EL SALVADOR
Electronic Associates
Apartado Postal 1682
Centro Comercial Gigante
San Salvador, El Salvador
Paseo Escalon 4649-4th Piso
Tel: 23-44-60, 23-32-37
Cable: ELECAS

MEXICO
Hewlett-Packard Mexicana, S.A.
de C.V.
622 Adolfo Prieto
Col. del Valle
Mexico 12, D.F.
Tel: 543-4232; 523-1874
Telex: 0017-74507

NICARAGUA
Roberto Terán G.
Apartado Postal 689
Edificio Terán
Managua
Tel: 3451, 3452
Cable: ROTERAN Managua

PANAMA
Electrónico Balboa, S.A.
P.O. Box 4929
Ave. Manuel Espinosa No. 13-50
Bldg. Alina
Panama City
Tel: 230833
Telex: 3481003, Curundu,
Canal Zone
Cable: ELECTRON Panama City

PARAGUAY
Z.T. Melamed S.R.L.
Division: Aparatos y Equipos
Medicus
Salon de Exposicion y Escritorio:
Chile 482
Edificio Victoria—Planta Baja
Asuncion, Paraguay
Tel: 4-5069, 4-6272
Cable: RAMEL

PERU
Compañia Electro Medica S.A.
Ave. Enrique Canauai 312
San Isidro
Casilla 1030
Lima
Tel: 22-3900
Cable: ELMED Lima

PUERTO RICO
San Juan Electronics, Inc.
P.O. Box 5167
Ponce de Leon 154
Pda. 3-PTA de Tierra
San Juan 00906
Tel: (809) 725-3342, 722-3342
Cable: SATRONICS San Juan
Telex: SATRON 3450 332

SURINAME
Surtel-Radio Holland N.V.
P.O. Box 155
Paramaribo
Tel: 72118
Cable: Treurniet Paramaribo

URUGUAY
Pablo Ferrando S.A.
Comercial e Industrial
Avenida Italia 2877
Casilla de Correo 370
Montevideo
Tel: 40-3102
Cable: RADIUM Montevideo

VENEZUELA
Hewlett-Packard De Venezuela
C.A.
Apartado 50933
Caracas
Tel: 71.88.05, 71.88.69, 71.99.30
Cable: HEWPACK Caracas
Telex: 39521146

FOR AREAS NOT LISTED,
CONTACT:
Hewlett-Packard
INTERCONTINENTAL
3200 Hillview Ave.
Palo Alto, California 94304
Tel: (415) 493-1501
TWX: 910-373-1267
Cable: HEWPACK Palo Alto
Telex: 034-8461

EUROPE

AUSTRIA
Hewlett-Packard Ges.m.b.H.
Imstrasse 23/2
Postfach 45
A-1204 Vienna
Tel: (0222) 33 66 06-09
Cable: HEWPAK Vienna
Telex: 75923 hewpak a

BELGIUM
Hewlett-Packard Benelux
S.A./N.V.
Avenue du Col-Vert, 1
B-1170 Brussels
Tel: (02) 72 22 40
Cable: PALOBEN Brussels
Telex: 23 494

DENMARK
Hewlett-Packard A/S
Datavej 38
DK-3460 Birkerød
Tel: (01) 81 66 40
Cable: HEWPAK AS
Telex: 16640 hp as

Hewlett-Packard A/S
Torvet 9
DK-8600 Silkeborg
Tel: (06)-82-71-66
Telex: 16640 hp as
Cable: HEWPAKAS

FINLAND
Hewlett-Packard Oy
Bulevardi 26
P.O. Box 12185
SF-00120 Helsinki 12
Tel: 13-730
Cable: HEWPAK OY-Helsinki
Telex: 12-1563

FRANCE
Hewlett-Packard France
Quartier de Courtaboeuf
Boite Postale No. 6
F-91 Orsay
Tel: (1) 907 78 25
Cable: HEWPAK Orsay
Telex: 60048

Hewlett-Packard France
4 Quai des Etoiles
F-69 Lyon 3ème
Tel: (78) 42 63 45
Cable: HEWPAK Lyon
Telex: 31617

Hewlett-Packard France
29 rue de la Gare
F-31 Blagnac
Tel: (61) 85 82 29
Telex: 51957

**GERMAN FEDERAL
REPUBLIC**
Hewlett-Packard Vertriebs-GmbH
Berliner Strasse 117
Postfach 560/40
D-6 Nieder-Eschbach/Ffm 56
Tel: (0611) 50-04-1
Cable: HEWPAKSA Frankfurt
Telex: 41 32 49 FRA

Hewlett-Packard Vertriebs-GmbH
Herrenbergstrasse 110
D-7030 Böblingen, Württemberg
Tel: (07031) 66 72 86
Cable: HEPAK Böblingen
Telex: 72 65 739

Hewlett-Packard Vertriebs-GmbH
Vogelsanger Weg 38
D-4 Düsseldorf
Tel: (0211) 63 80 31/35
Telex: 85/86 533

Hewlett-Packard Vertriebs-GmbH
Wendenstr. 23
D-2 Hamburg 1
Tel: (0411) 24 05 51/52
Cable: HEWPAKSA Hamburg
Telex: 21 53 32

Hewlett-Packard Vertriebs-GmbH
Unterhachinger Strasse 28
ISAR Center
D-8012 Ottobrunn
Tel: (0811) 60 13 061-7
Telex: 05-24985
Cable: HEWPAKSA München

(West Berlin)
Hewlett-Packard Vertriebs-GmbH
Wilmsdorfer Strasse 113/114
D-1000 Berlin W. 12
Tel: (0311) 3137046
Telex: 18 34 05

GREECE
Kostas Karayannis
18, Ermou Street
Athens 126
Tel: 230301,3,5
Cable: RAKAR Athens
Telex: 21 59 62 RKAR GR

IRELAND
Hewlett-Packard Ltd.
224 Bath Road
Slough, SL1 4 DS, Bucks
Tel: Slough 753-33341
Telex: 84413

ITALY
Hewlett-Packard Italiana S.p.A.
Via Amerigo Vesputici 2
I-20124 Milan
Tel: (2) 6251 (10 lines)
Cable: HEWPAKIT Milan
Telex: 32046

Hewlett-Packard Italiana S.p.A.
Via Marocco, 7
I-00144 Rome - Eur
Tel: (6) 5912544/5, 5915947
Cable: HEWPAKIT Rome
Telex: 61514

LUXEMBURG
Hewlett-Packard Benelux
S.A./N.V.
Avenue du Col-Vert, 1
B-1170 Brussels
Tel: (03/02) 72 22 40
Cable: PALOBEN Brussels
Telex: 23 494

NETHERLANDS
Hewlett-Packard Benelux, N.V.
Weerdestein 117
P.O. Box 7825
Amsterdam, Z 11
Tel: 020-42 77 77
Cable: PALOBEN Amsterdam
Telex: 13 216

NORWAY
Hewlett-Packard Norge A/S
Box 149
Nesveien 13
N-1344 Haslum
Tel: (02)-53 83 60
Telex: 16621

PORTUGAL
Teletra-Empresa Tecnica de
Equipamentos
Electricos S.a.r.l.
Rua Rodrigo da Fonseca 103
P.O. Box 2531
Lisbon 1
Tel: 68 60 72
Cable: TELETRA Lisbon
Telex: 1598

SPAIN
Hewlett-Packard Española, S.A.
Jerez No 8
Madrid 16
Tel: 458 26 00

SWEDEN
Hewlett-Packard Sverige AB
Enighetsvägen 1-3
Fack
S-161 20 Bromma 20
Tel: (08) 98 12 50
Cable: MEASUREMENTS
Stockholm
Telex: 10721

Hewlett-Packard Sverige AB
Hagakergatan 9C
S-431 41 Mölndal
Tel: (031) 27 68 00/01
Telex: 21 312 hpminds

SWITZERLAND
Hewlett-Packard (Schweiz) AG
Zürcherstrasse 20
CH-8952 Schlieren Zurich
Tel: (01) 98 18 21/24
Cable: HPAG CH
Telex: 53933

Hewlett-Packard (Schweiz) AG
Rue du Bois-du-Lan 7
P.O. Box 85
1217 Meyrin 2 Geneva
Tel: (022) 41 54 00
Cable: HEWPAKSA Geneva
Telex: 27333 HPSA CH

TURKEY
Telekom Engineering Bureau
P.O. Box 376
Karaköy
Istanbul
Tel: 48 40 40
Cable: TELEMATON Istanbul

UNITED KINGDOM
Hewlett-Packard Ltd.
224 Bath Road
Slough, SL1 4 DS, Bucks
Tel: Slough (0753) 33341
Cable: HEWPIE Slough
Telex: 84413

Hewlett-Packard Ltd.
"The Graftons"
Stamford New Road
Atrincham, Cheshire
Tel: (061) 928-8626
Telex: 680658

YUGOSLAVIA
Belram S.A.
83 avenue des Mimosas
Brussels 1150, Belgium
Tel: 34 33 32, 34 26 19
Cable: BELRAMEL Brussels
Telex: 21790

**SOCIALIST COUNTRIES
PLEASE CONTACT:**
Hewlett-Packard Ges.m.b.H.
Imstrasse 23/2
Postfach 45
A-1204 Vienna, Austria
Tel: (0222) 33 66 06-09
Cable: HEWPAK Vienna
Telex: 75923 hewpak a

**ALL OTHER EUROPEAN
COUNTRIES CONTACT:**
Hewlett-Packard S.A.
Rue du Bois-du-Lan 7
1217 Meyrin 2 Geneva
Switzerland
Tel: (022) 41 54 00
Cable: HEWPAKSA Geneva
Telex: 2.24.86

AFRICA, ASIA, AUSTRALIA

ANGOLA
Teletra Empresa Técnica
de Equipamentos Eléctricos
SAR
Rua de Barbosa Rodrigues
42-15
Box 6487
Luanda
Cable: TELETRA Luanda

AUSTRALIA
Hewlett-Packard Australia
Pty. Ltd.
22-26 Weir Street
Glen Iris, 3146
Victoria
Tel: 20.1371 (6 lines)
Cable: HEWPAK Melbourne
Telex: 31024

Hewlett-Packard Australia
Pty. Ltd.
61 Alexander Street
Crowe Nest 2065
New South Wales
Tel: 43.7866
Cable: HEWPAK Sydney
Telex: 21561

Hewlett-Packard Australia
Pty. Ltd.
97 Churchill Road
Prospect 5082
South Australia
Tel: 65.2366
Cable: HEWPAK Adelaide

Hewlett-Packard Australia
Pty. Ltd.
2nd Floor, Suite 13
Casablanca Buildings
196 Adelaide Terrace
Perth, W.A. 6000
Tel: 21-3330
Cable: HEWPAK Perth

Hewlett-Packard Australia
Pty. Ltd.
10 Woolley Street
P.O. Box 191
Dickson A.C.T. 2602
Tel: 49-8194
Cable: HEWPAK Canberra ACT

Hewlett-Packard Australia
Pty. Ltd.
6 Harvard Street
P.O. Box 135
Kenmore 4069 Queensland
Tel: 78 6069

CEYLON
United Electricals Ltd.
P.O. Box 681
Yahala Building
Staples Street
Colombo 2
Tel: 5496
Cable: HOTPOINT Colombo

CYPRUS
Kypronic
19 Gregorios & Xenopoulos Road
P.O. Box 1152
Nicosia
Tel: (0282) 75628
Cable: HE-I-NAMI

ETHIOPIA
African Salespower & Agency
Private Ltd., Co.
P.O. Box 718
58/59 Cunningham St.
Addis Ababa
Tel: 12285
Cable: ASACO Addisababa

HONG KONG
Schmidt & Co. (Hong Kong) Ltd.
P.O. Box 297
1511, Prince's Building 15th Floor
10, Chater Road
Hong Kong
Tel: 240168, 232735
Cable: SCHMIDTCO Hong Kong
Telex: 31024

INDIA
Blue Star Ltd.
Kasturi Buildings
Jamshedi Tata Rd.
Bombay 20BR, India
Tel: 29 50 21
Telex: 2156
Cable: BLUEFROST

Blue Star Ltd.
Band Box House
Prabhadevi
Bombay 25DD, India
Tel: 45 73 01
Telex: 2156
Cable: BLUESTAR

Blue Star Ltd.
14/40 Civil Lines
Kanpur, India
Tel: 6 88 82
Cable: BLUESTAR

Blue Star Ltd.
7 Hare Street
P.O. Box 506
Calcutta 1, India
Tel: 23-0131
Telex: 655
Cable: BLUESTAR

Blue Star Ltd.
Blue Star House,
34 Ring Road
Lajpat Nagar
New Delhi 24, India
Tel: 62 32 76
Telex: 463
Cable: BLUESTAR

Blue Star Ltd.
17-C Ulsoor Road
Bangalore-8

Blue Star, Ltd.
96 Park Lane
Secunderabad 3, India
Tel: 7 63 91
Cable: BLUEFROST

Blue Star, Ltd.
23/24 Second Line Beach
Madras 1, India
Tel: 2 39 55
Telex: 379
Cable: BLUESTAR

Blue Star, Ltd.
1B Kaiser Bungalow
Dindli Road
Jamshedpur, India
Tel: 38 04
Cable: BLUESTAR

INDONESIA
Bah Bolon Trading Coy. N.V.
Djalal Merdeka 29
Bandung
Tel: 4915; 51560
Cable: ILMU
Telex: 08-809

IRAN
Telecom, Ltd.
P. O. Box 1812
240 Kh. Saba Shomali
Teheran
Tel: 43850, 48111
Cable: BASDOM Teheran
Telex: 2664

ISRAEL
Electronics & Engineering
Div. of Motorola Israel Ltd.
17 Aminadav Street
Tel-Aviv
Tel: 36941 (3 lines)
Cable: BASTEL Tel-Aviv
Telex: Bastei Tv 033-569

JAPAN
Yokogawa-Hewlett-Packard Ltd.
Ohashi Building
1-59-1 Yoyogi
Shibuya-ku, Tokyo
Tel: 03-370-2281/7
Telex: 232-2024YHP
Cable: YHPMARKET TOK 23-724

Yokogawa-Hewlett-Packard Ltd.
Nisei Ibaragi Bldg.
2-2-8 Kasuga
Ibaragi-Shi
Osaka
Tel: (0726) 23-1641
Telex: 385-5332 YHOSAKA

Yokogawa-Hewlett-Packard Ltd.
Ito Building
No. 59, Kotori-cho
Nakamura-ku, Nagoya City
Tel: (052) 551-0215

Yokogawa-Hewlett-Packard Ltd.
Nitto Bldg.
2300 Shinohara-cho,
Kohoku-ku
Yokohama 222
Tel: (405) 432-1504/5

JORDAN
Constantin E. Macridis
Clemenceau Street
P.O. Box 7213
Beirut, Lebanon
Tel: 220846
Cable: ELECTRONUCLEAR Beirut

KENYA
Kenya Kinetics
P.O. Box 18311
Nairobi, Kenya
Tel: 57726
Cable: PROTON

KOREA
American Trading Co.,
Korea, Ltd.
Seoul P.O. Box 1103
7th & 8th floors, Daekyung Bldg.
107 Sejong Ro
Chongro-Ku, Seoul
Tel: 75-5841 (4 lines)
Cable: AMTRACO Seoul

LEBANON
Constantin E. Macridis
Clemenceau Street
P.O. Box 7213
Beirut
Tel: 220846
Cable: ELECTRONUCLEAR Beirut

MALAYSIA
MECOMB Malaysia Ltd.
2 Lorong 13/6A
Section 13
Petaling Jaya, Selangor
Cable: MECOMB Kuala Lumpur

MOZAMBIQUE
A. N. Goncalves, LDA.
4.1 Apt. 14 Av. D. Luis
P.O. Box 107
Lourenço Marques
Cable: NEGON

NEW ZEALAND
Hewlett-Packard (N.Z.) Ltd.
94-96 Dixon St.
P.O. Box 9443
Wellington, N.Z.
Tel: 56-555
Cable: HEWPACK Wellington

Hewlett-Packard (N.Z.) Ltd.
Box 51002
Pukuranga
Tel: 569-651
Cable: HEWPACK, Auckland

PAKISTAN (EAST)
Mushko & Company, Ltd.
1, Jinnah Avenue
Dacca 2
Tel: 280058
Cable: NEWDEAL Dacca

PAKISTAN (WEST)
Mushko & Company, Ltd.
Osman Chambers
Abdullah Haroon Road
Karachi 3
Tel: 511027, 512927
Cable: COOPERATOR Karachi

Mushko & Company, Ltd.
38B, Satellite Town
Rawalpindi
Tel: 41924
Cable: FEMUS Rawalpindi

PHILIPPINES
Electromex Inc.
5th Floor, Architects
Center Bldg.
Ayala Ave., Makati, Rizal
C.C.P.O. Box 1028
Makati, Rizal
Tel: 86-18-87, 87-76-77
Cable: ELEMEX Manila

SINGAPORE
Mechanical and Combustion
Engineering Company Ltd.
9, Jalan Kilang
Red Hill Industrial Estate
Singapore, 3
Tel: 642361-3; 632611
Cable: MECOMB Singapore

Hewlett-Packard Far East
Area Office
P.O. Box 87
Alexandra Post Office
Singapore 3
Tel: 633022
Cable: HEWPACK SINGAPORE

SOUTH AFRICA
Hewlett-Packard South Africa
(Pty.), Ltd.
P.O. Box 31716
Braamfontein Transvaal
Milnerton
30 De Beer Street
Johannesburg
Tel: 725-2080, 725-2030
Telex: 0226 JH
Cable: HEWPACK Johannesburg

Hewlett-Packard South Africa
(Pty.), Ltd.
Breechle House
Bree Street
Cape Town
Tel: 3-6019, 3-6545
Cable: HEWPACK Cape Town
Telex: 5-0006

Hewlett-Packard South Africa
(Pty.), Ltd.
641 Ridge Road, Durban
P.O. Box 99
Overport, Natal
Tel: 88-6102
Telex: 567954
Cable: HEWPACK

TAIWAN
Hewlett-Packard Taiwan
39 Chung Shiao West Road
Sec. 1
Overseas Insurance
Co's Bldg. 7th Floor
Taipei
Tel: 389160, 1.2, 375121,
Ext. 240
Telex: TP824 HEWPAK
Cable: HEWPACK Taipei

THAILAND
The International
Engineering Co., Ltd.
P. O. Box 39
614 Sukhumvit Road
Bangkok
Tel: 910722 (7 lines)
Cable: GYSOM
TLX INTENCO BK-226 Bangkok

UGANDA
Uganda Tele-Electric Co., Ltd.
P.O. Box 4449
Kampala
Tel: 57279
Cable: COMCO Kampala

VIETNAM
Peninsular Trading Inc.
P.O. Box H-3
216 Hien-Vuong
Saigon
Tel: 20805, 93398
Cable: PENTRA, SAIGON 242

ZAMBIA
R. J. Tilbury (Zambia) Ltd.
P.O. Box 2792
Lusaka
Zambia, Central Africa
Tel: 73793
Cable: ARJAYTEE, Lusaka

**MEDITERRANEAN AND
MIDDLE EAST COUNTRIES
NOT SHOWN PLEASE
CONTACT:**
Hewlett-Packard
Co-ordination Office for
Mediterranean and Middle
East Operations
Via Marocco, 7
I-00144 Rome-Eur, Italy
Tel: (6) 59 40 29
Cable: HEWPAKIT Rome
Telex: 61514

**OTHER AREAS NOT
LISTED, CONTACT:**
Hewlett-Packard
INTERCONTINENTAL
3200 Hillview Ave.
Palo Alto, California 94304
Tel: (415) 326-7000
(Feb. 71 493-1501)
TWX: 910-373-1267
Cable: HEWPAK Palo Alto
Telex: 034-8461